

为客户创造价值，以诚信铸就基业。
with honesty as foundation to Create Value for Customers

浙江乐鼎波纹管有限公司 TEL: 0577-82567776

YUEDING 乐鼎



浙江乐鼎波纹管有限公司

ZHEJIANG YUEDING CORRUGATED TUBE CO.,LTD.

ADD/地址：浙江省温州乐清市南塘镇交通西路
JIAOTONG WEST ROAD, NANTANG TOWN, YUEQING
WENZHOU, ZHEJIANG, CHINA
PC/邮编：325608

OVERSEA DEPARTMENT:

Mail: bessie@yueguan.cn
Tel: 0086-577-62250902/62250910
Fax: 0086-577-62250878
Http://www.yuedingexhaust.com

国内销售部：

邮箱: pipe@yueguan.cn
电话：0577-62257867 / 62252888
传真：0577-62251903
Http://www.yueguan.com

浙江乐鼎波纹管有限公司

ZHEJIANG YUEDING CORRUGATED TUBE CO.,LTD.



COMPANY PROFILE

企业介绍 >>

浙江乐鼎波纹管有限公司创建于1992年，占地面积3万平方米，位于浙江省温州市乐清市南塘工业区，公司员工300多人，注册资金3680万元，年产值超亿元，是中国石油天然气集团公司能源一号网成员、中国石化集团公司一级网络成员、中国汽车工业协会会员、浙江省高新技术企业、浙江省百家诚信优秀企业。

公司通过ISO9001、ISO14001、ISO/TS16949国际管理体系认证，拥有国家发明专利1项、实用新型专利30余项、国家火炬计划项目3项、科技部创新基金项目1项，是石油储罐中央排水系统行业标准（标准号：SY/T0511.6-2010）参加起草单位。

公司主导产品有：汽车排气挠性波纹管、金属波纹补偿器（膨胀节）、金属波纹管软管、纤维织物补偿器等，产品以质量优异、价格合理畅销国内各省、市、自治区，并出口欧美等50多个国家，广泛应用于石油、化工、电力、汽配、燃气、压缩机等行业。

展望未来，志存高远，自主创新的乐鼎人将继续发扬“质量第一、用户第一、信誉第一”的经营宗旨，大力发扬“诚信、创新、发展、双赢”的企业精神和“严谨、高效、热情、文明”的企业作风，以更加饱满的热情、强烈的进取心以及谦虚友好的合作态度，齐心协力共创企业辉煌。

Zhejiang Yueding Corrugated Tube co.,Ltd is one of the leading professional manufacturers when it comes to the exhaust flexible pipe, metal hose. We pride ourselves on research, development, handle production and sales on our own. At YueDing, we passed ISO9001:2008 quality management system, ISO14001:2004 environmental management system certifications as well as ISO/TS 16949.

We produce quality products and work to provide constant communication with our clients. Our dedication to excellence allows us to be a stable solution in the marketplace with a quick lead time. We primarily focus on exhaust pipes, including metal hoses and other pipes that are used within the automotive industry. Perhaps what we are best known for is our stainless steel auto parts, which are sold globally and used as an aftermarket product. Also, Yueding has had great success because of a team effort. We have designers, engineers, and others who are involved in the process of manufacturing parts. We explore the top materials to use as well as continuously add more technology and innovation to produce higher quality parts. It has helped us to gain the popularity that we have because we offer a good product at a good price.

We are continuously improving all aspects for our customers and look to create a successful partnership with each and every customer. Learn more about Yueding by sharing with us today.

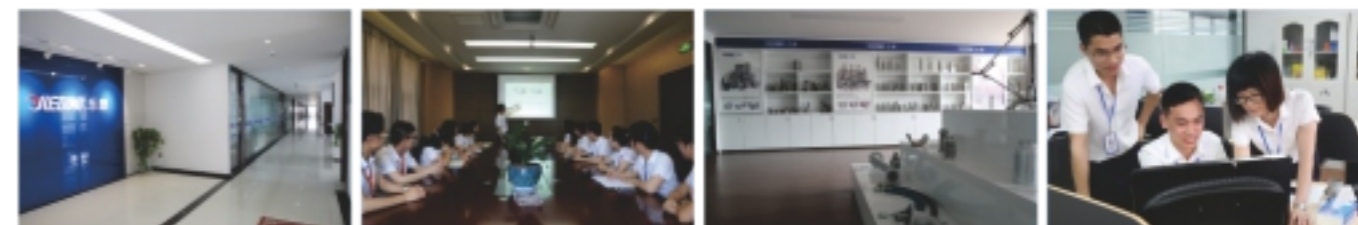

A letter to all our customers,
致客户的一封信



当您看到这封信的时候，我知道您一定不是陌生人，也不是过客，而是我们亲爱的朋友。在这里，有丰富的产品，优异的品质，真诚的服务以及最有活力的团队，期待与您合作！

Dear Valued Customers,

Thank you for taking the time to read this message. It is our desire to establish a relationship with you throughout our transactions. We do not want to be strangers. Instead, we want to build a rapport and make sure we are able to help you in all regards.

Browse through our catalog of products and be confident that YUEDING is the right manufacturer for your needs. We are able to provide you with quality products that you can count on again and again.

We promise to have great communication with you and we want your impression of us to include the ability to:

- Provide warm service
- Offer a quick lead time
- Be stable
- Sell quality items

We may be in business, but our goal is to be more than just a business. We want to make friends all over the world, and this begins with properly introducing ourselves.

It is our sincerest hope that we are able to make friends and establish a successful cooperation that will lead to a brighter future.

Should you require anything from us to improve your shopping experience, please do not hesitate to reach out.

Thank you.

YueDing company all sales



CERTIFICATE 企业认证 »

以顾客需求为导向、以科技创新为手段、以管理和产品质量升级为保证。持续改进不断满足和超越顾客的需求。

Guided by the demands of customers. By means of science and technology innovation. To manage and upgrade in order to ensure product quality. Continuous improvement, constantly meet and exceed customer demand

UNITY ENDEAVOR CREATION 团结奋进 共创辉煌

24年来，乐鼎始终坚持自主发展，把培育自主创新能力作为企业核心竞争力的重中之重，以科技创新推动产品的革新与升级。2007年被认定为浙江省高新技术企业，2010年成立乐鼎科技分公司，现有国家火炬计划项目3项，科技部创新基金项目1项，有效专利总数近50项。

In the past 24 years of YUEDING history, rely on the power of science and technology to promote innovation and upgrading of products, actively carrying out technical exchanges and cooperation. With nearly 100 effective patents, Was identified as "high-tech enterprise". YUEDING adhere to the scientific and technological innovation as the breach of the transformation and upgrading, constantly to provide customers with competitive products and services, always on the road of innovation and development.



WHAT OUR CUSTOMERS SAY ABOUT US

客户的满意是我们前进的动力！

This is excellent. You provided more information that I was expecting---Holly

Dear, I will be your friend my entire life, although human's life is finite----John

We want to keep long term cooperation with your company, you are professionals. -----Nair

Thanks for your attention and concern with our business. Hope to keep this business relationship with your company for many many years.-----Michael

I like your active mind and your professional work -----Antonio

we appreciate your price policy to protect your valued customer -----Ubomir



BASE

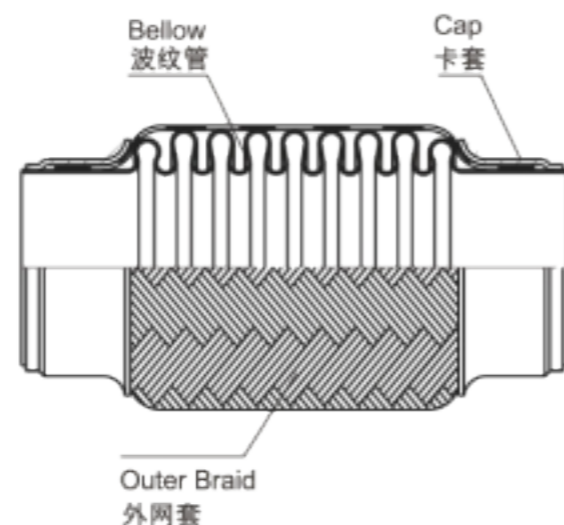

Part Number	Inlet Diameter (Inch)	Inlet Diameter (mm)	overall Length (inch)	overall length (mm)
产品代码	内径	内径	产品总长	产品总长
YD17504	1 3/4"	45	4"	102
YD17506	1 3/4"	45	6"	152
YD17508	1 3/4"	45	8"	203
YD17510	1 3/4"	45	10"	254
YD17512	1 3/4"	45	12"	305
YD20004	2"	51	4"	102
YD20006	2"	51	6"	152
YD20008	2"	51	8"	203
YD20010	2"	51	10"	254
YD20012	2"	51	12"	305
YD22504	2 1/4"	57	4"	102
YD22506	2 1/4"	57	6"	152
YD22508	2 1/4"	57	8"	203
YD22510	2 1/4"	57	10"	254
YD22512	2 1/4"	57	12"	305
YD25004	2 1/2"	63.5	4"	102

Part Number	Inlet Diameter (Inch)	Inlet Diameter (mm)	overall Length (inch)	overall length (mm)
产品代码	内径	内径	产品总长	产品总长
YD25006	2 1/2"	63.5	6"	152
YD25008	2 1/2"	63.5	8"	203
YD25010	2 1/2"	63.5	10"	254
YD25012	2 1/2"	63.5	12"	305
YD30004	3"	76.2	4"	102
YD30006	3"	76.2	6"	152
YD30008	3"	76.2	8"	203
YD30010	3"	76.2	10"	254
YD30012	3"	76.2	12"	305
YD35006	3 1/2"	89	6"	152
YD35008	3 1/2"	89	8"	203
YD35010	3 1/2"	89	10"	254
YD35012	3 1/2"	89	12"	305
YD40008	4"	102	8"	203
YD40010	4"	102	10"	254
YD40012	4"	102	12"	305

备注 (Remarks) : 国内常用的产品直径有39mm,43mm,45mm,50/51mm,54mm,57mm,61mm,63.5mm,65mm,70mm,76mm,89mm,101mm等等,未例出的其它尺寸也都可以订做。(ALL the other sizes can be customized)

我们公司生产的汽车排气挠性管是以水为介质高压成型制出，制出的波纹管减少了应力的聚集。
Our automobile exhaust flexible pipe are High pressure produced with water as medium ,making corrugated pipe with less aggregation of Stress in structure.

我们通过增加波纹的高度来提高波纹管的柔软性，能够更好的吸收多方面的震动、补偿安装位移与热胀冷缩，延长排气消声系统寿命。

We improve the flexibility of bellows by increasing the height of the waves, it can help in absorbing a variety of vibration, Expansion&Contraction, Compensation installation displacement and extending the life of the exhaust muffler system.

由于波纹管工作在高温及复杂的环境中，因此不锈钢SUS304用作挠性管的主要材料，它可承受高温和盐分的腐蚀，使产品寿命更长。

As the normal working condition of bellows are under high temperature and complex environment , therefore we use stainless steel SUS304 as the main material of flexible pipe , it can bear high temperature and salt corrosion , make the product life longer

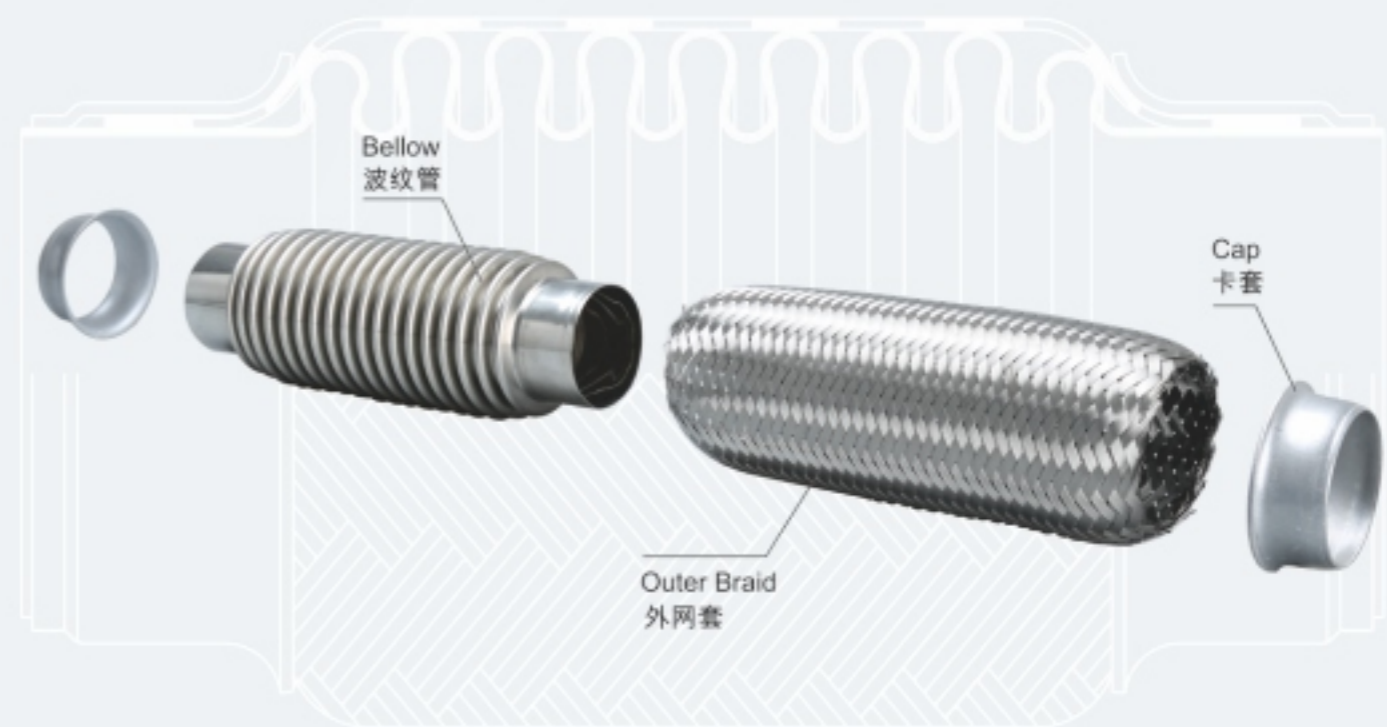

With Inner Braid

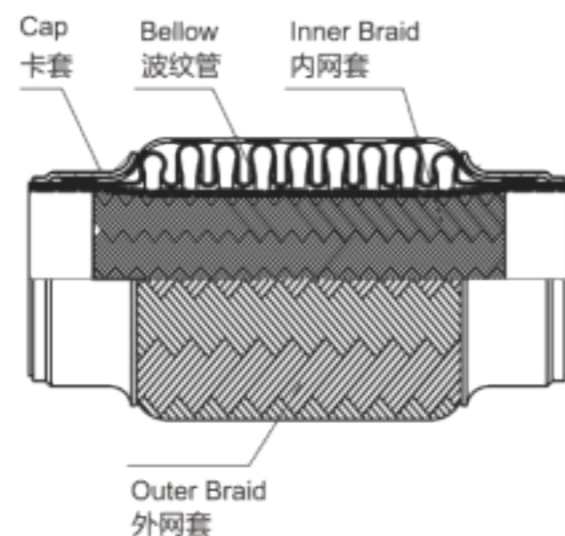

我们在波纹管内部配置了网套，使通过挠性管的气流更加顺畅，同时降低了排气噪声，提高了排气系统的消声作用。

We configurate inside the corrugated pipe with inner braid , make air flow through flexible pipe more smoothly , reduce the exhaust noise , and improve the noise elimination function of exhaust system

Part Number	Inlet Diameter (Inch)	Inlet Diameter (mm)	overall Length (inch)	overall length (mm)
产品代码	内径	内径	产品总长	产品总长
YD17504B	1 3/4"	45	4"	102
YD17506B	1 3/4"	45	6"	152
YD17508B	1 3/4"	45	8"	203
YD17510B	1 3/4"	45	10"	254
YD17512B	1 3/4"	45	12"	305
YD20004B	2"	51	4"	102
YD20006B	2"	51	6"	152
YD20008B	2"	51	8"	203
YD20010B	2"	51	10"	254
YD20012B	2"	51	12"	305
YD22504B	2 1/4"	57	4"	102
YD22506B	2 1/4"	57	6"	152
YD22508B	2 1/4"	57	8"	203
YD22510B	2 1/4"	57	10"	254
YD22512B	2 1/4"	57	12"	305
YD25004B	2 1/2"	63.5	4"	102

Part Number	Inlet Diameter (Inch)	Inlet Diameter (mm)	overall Length (inch)	overall length (mm)
产品代码	内径	内径	产品总长	产品总长
YD25006B	2 1/2"	63.5	6"	152
YD25008B	2 1/2"	63.5	8"	203
YD25010B	2 1/2"	63.5	10"	254
YD25012B	2 1/2"	63.5	12"	305
YD30004B	3"	76.2	4"	102
YD30006B	3"	76.2	6"	152
YD30008B	3"	76.2	8"	203
YD30010B	3"	76.2	10"	254
YD30012B	3"	76.2	12"	305
YD35006B	3 1/2"	89	6"	152
YD35008B	3 1/2"	89	8"	203
YD35010B	3 1/2"	89	10"	254
YD35012B	3 1/2"	89	12"	305
YD40008B	4"	102	8"	203
YD40010B	4"	102	10"	254
YD40012B	4"	102	12"	305

备注 (Remarks) : 国内常用的产品直径有39mm,43mm,45mm,50/51mm,54mm,57mm,61mm,63.5mm,65mm,70mm,76mm,89mm,101mm等等，未例出的其它尺寸也都可以订做。(ALL the other sizes can be customized)

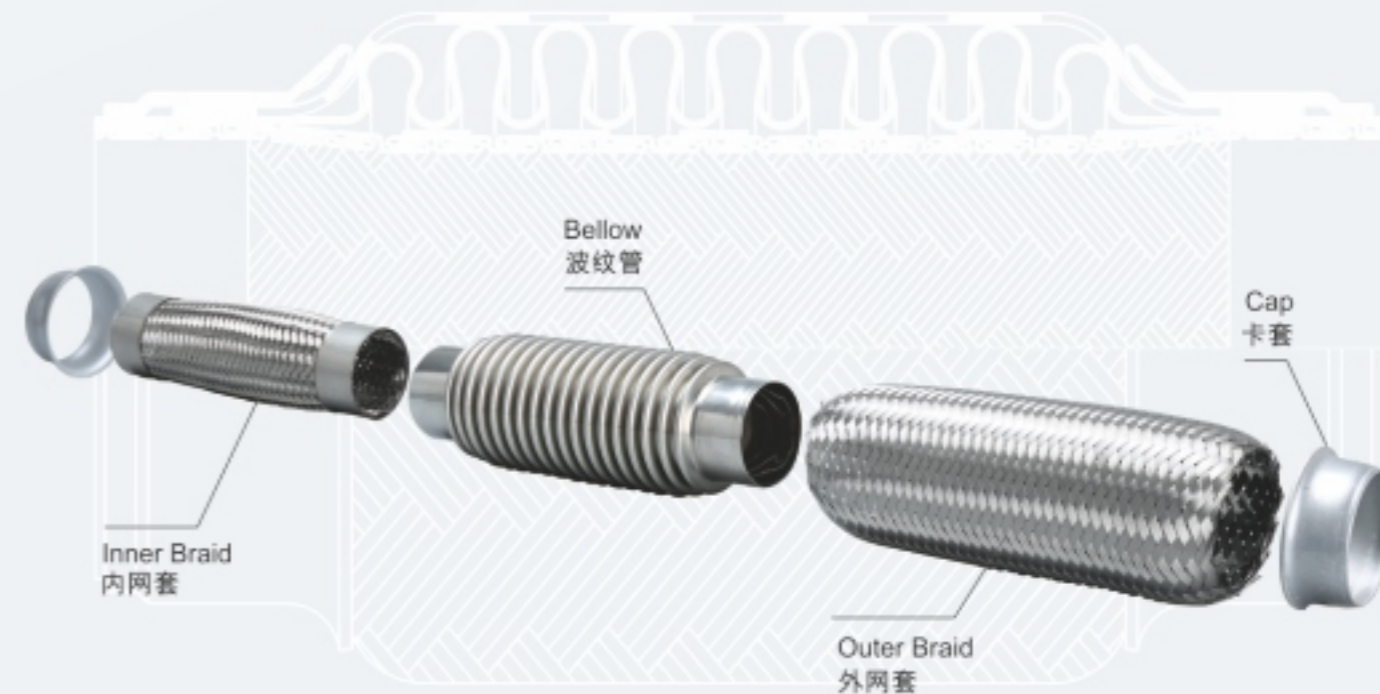

With Interlock

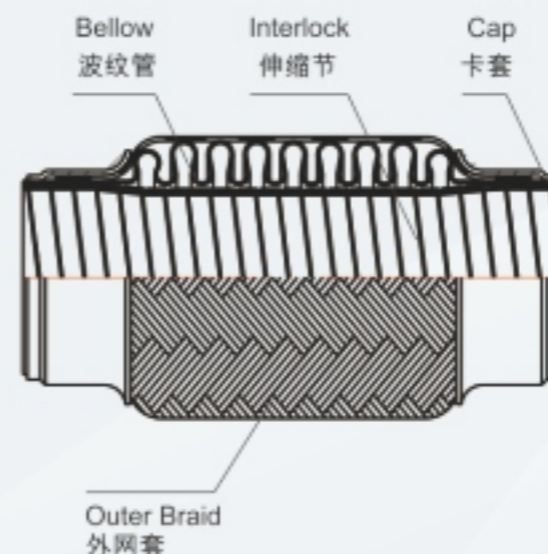
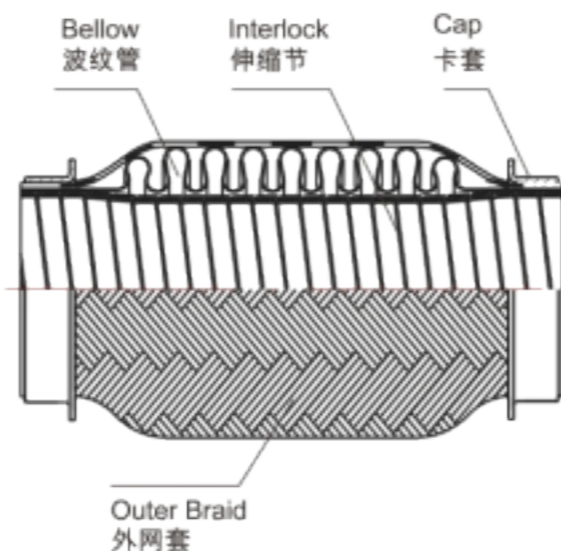

我们公司生产的伸缩节波纹管可承受高温和盐分的腐蚀。

我们在波纹管内部配置了伸缩节，它不仅可减少流阻，降低排气噪声和震动，同时它能够耐更高的温度，增加了挠性管的强度，使产品寿命更长。

Our configuration inside the bellows with interlock hose, it not only can reduce the flow resistance, the exhaust noise and vibration, but also can be resistant to higher temperature, increase the strength of flexible pipe, make the product life longer.

Part Number	Inlet Diameter (Inch)	Inlet Diameter (mm)	overall Length (inch)	overall length (mm)
产品代码	内径	内径	产品总长	产品总长
YD17504L	1 3/4"	45	4"	102
YD17506L	1 3/4"	45	6"	152
YD17508L	1 3/4"	45	8"	203
YD17510L	1 3/4"	45	10"	254
YD17512L	1 3/4"	45	12"	305
YD20004L	2"	51	4"	102
YD20006L	2"	51	6"	152
YD20008L	2"	51	8"	203
YD20010L	2"	51	10"	254
YD20012L	2"	51	12"	305
YD22504L	2 1/4"	57	4"	102
YD22506L	2 1/4"	57	6"	152
YD22508L	2 1/4"	57	8"	203
YD22510L	2 1/4"	57	10"	254
YD22512L	2 1/4"	57	12"	305
YD25004L	2 1/2"	63.5	4"	102

Part Number	Inlet Diameter (Inch)	Inlet Diameter (mm)	overall Length (inch)	overall length (mm)
产品代码	内径	内径	产品总长	产品总长
YD25006L	2 1/2"	63.5	6"	152
YD25008L	2 1/2"	63.5	8"	203
YD25010L	2 1/2"	63.5	10"	254
YD25012L	2 1/2"	63.5	12"	305
YD30004L	3"	76.2	4"	102
YD30006L	3"	76.2	6"	152
YD30008L	3"	76.2	8"	203
YD30010L	3"	76.2	10"	254
YD30012L	3"	76.2	12"	305
YD35006L	3 1/2"	89	6"	152
YD35008L	3 1/2"	89	8"	203
YD35010L	3 1/2"	89	10"	254
YD35012L	3 1/2"	89	12"	305
YD40008L	4"	102	8"	203
YD40010L	4"	102	10"	254
YD40012L	4"	102	12"	305

备注 (Remarks) : 国内常用的产品直径有39mm,43mm,45mm,50/51mm,54mm,57mm,61mm,63.5mm,65mm,70mm,76mm, 89mm,101mm等等,未例出的其它尺寸也都可以订做。(ALL the other sizes can be customized)

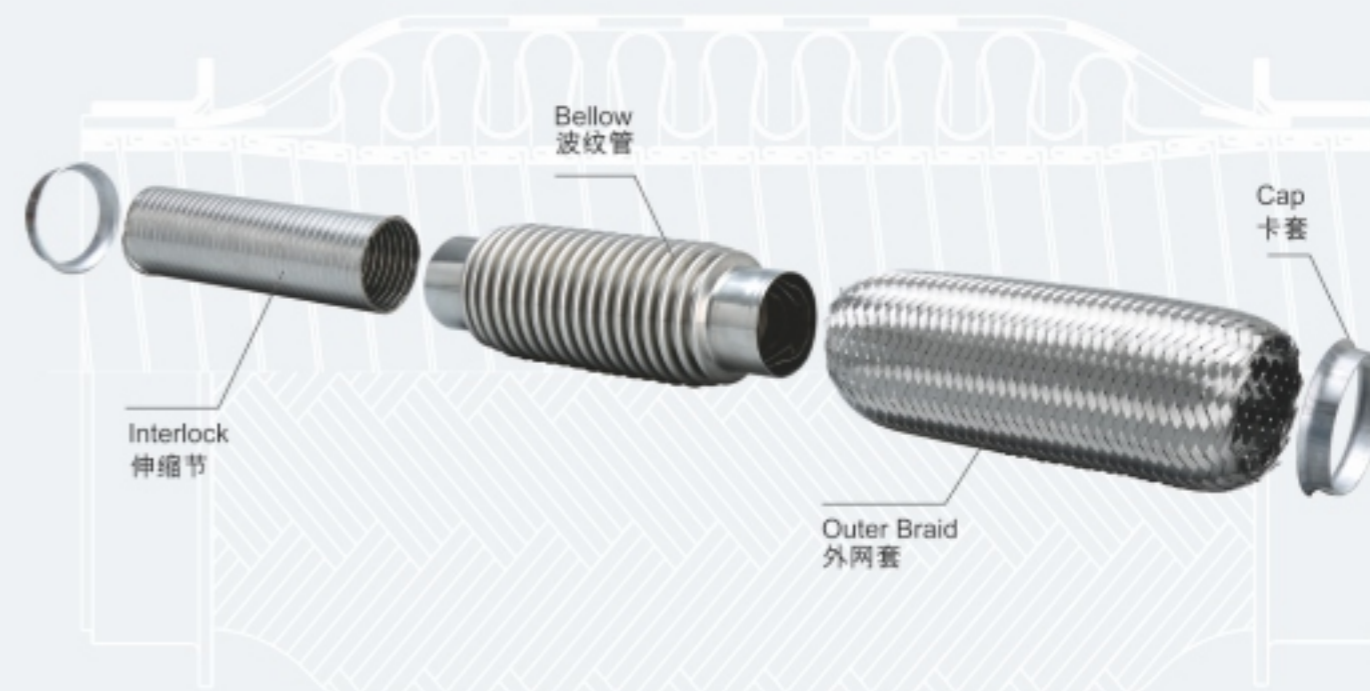

With Nipple

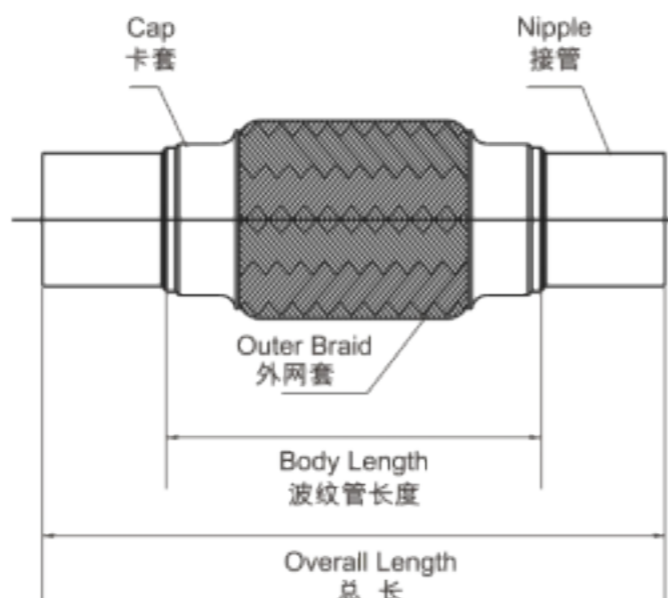

Part Number 产品代码	Inlet Diameter (Inch) 内径	Inlet Diameter (mm) 内径	body Length (inch) 波纹管长度	body Length (mm) 波纹管长度	overall Length (inch) 产品总长	overall length (mm) 产品总长
YD17504N	1 3/4"	45	4"	102	8"	203
YD17506N	1 3/4"	45	6"	152	10"	254
YD17508N	1 3/4"	45	8"	203	12"	305
YD17510N	1 3/4"	45	10"	254	14"	356
YD20004N	2"	51	4"	102	8"	203
YD20006N	2"	51	6"	152	10"	254
YD20008N	2"	51	8"	203	12"	305
YD20010N	2"	51	10"	254	14"	356
YD22504N	2 1/4"	57	4"	102	8"	203
YD22506N	2 1/4"	57	6"	152	10"	254
YD22508N	2 1/4"	57	8"	203	12"	305
YD22510N	2 1/4"	57	10"	254	14"	356
YD25004N	2 1/2"	63.5	4"	102	8"	203
YD25006N	2 1/2"	63.5	6"	152	10"	254
YD25008N	2 1/2"	63.5	8"	203	12"	305
YD25010N	2 1/2"	63.5	10"	254	14"	356
YD30004N	3"	76.2	4"	102	8"	203
YD30006N	3"	76.2	6"	152	10"	254
YD30008N	3"	76.2	8"	203	12"	305
YD30010N	3"	76.2	10"	254	14"	356
YD35006N	3 1/2"	89	6"	152	10"	254
YD35008N	3 1/2"	89	8"	203	12"	305
YD35010N	3 1/2"	89	10"	254	14"	356
YD40008N	4"	102	8"	203	12"	305
YD40010N	4"	102	10"	254	14"	356

备注 (Remarks): 国内常用的产品直径有39mm,43mm,45mm,50/51mm,54mm,57mm,61mm,63.5mm,65mm,70mm,76mm,89mm,101mm等等,未例出的其它尺寸也都可以订做。(ALL the other sizes can be customized)

为了解决部分客户焊接难的困扰，我们在挠性管的两端口加焊了一段钢管，降低了挠性管的焊接难度，使其焊接性更好，适合改装车型。

In order to solve the difficulties while welding our flex pipe to exhaust system.

We welded on the two ends of the flexible tube with extension steel pipes, make its better welding ability, which is suitable for modified models. The length of the nipple can be customized.

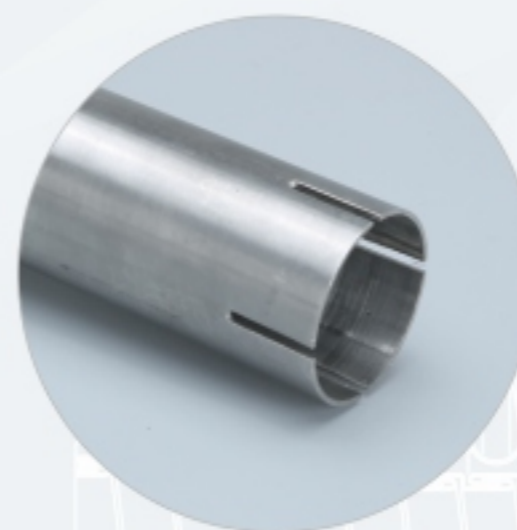

为了方便客户安装及节约焊接成本，我们对接管两端进行开槽后，可以直接用卡箍连接。

In order to facilitate the installation and save cost for customers, we have nipples slotted at both ends, so that they can be connected by clamps directly.

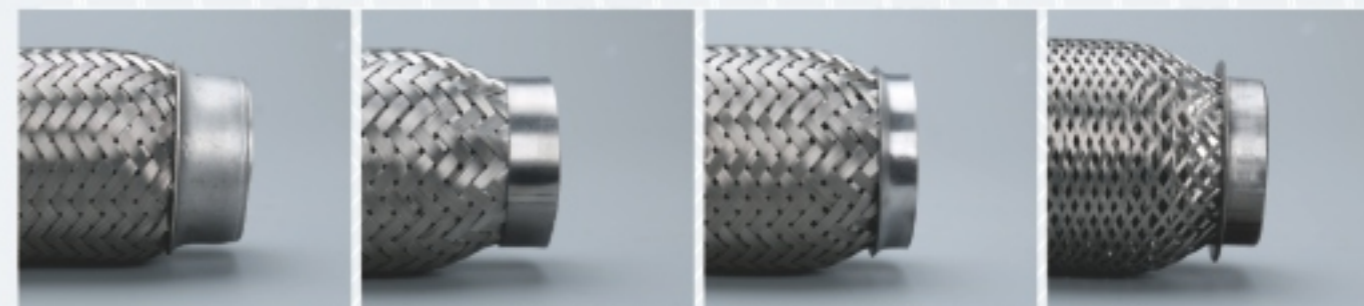

"K2" Type

"P" type

"K1" type

"90°" type

Mesh Braid / Open Braid



稀网和勾花网这两款产品的网套覆盖率比常规网套低，大大提高了产品的柔软性，并且降低了网套和波纹管之间的摩擦，提高了网套耐磨性，给整车提供了舒适的乘车感等优点。

That the coverage of thin braid and mesh braid is much lower than conventional samples, which greatly improve the flexibility, and reduces the friction between the net and corrugated pipe. The wear resistance of the net will be also improved, provide the vehicle with comfortable ride quality.

Flex pipe for small gas/diesel engines



DN25和DN32两款通径的挠性管适用于迷你车和两轮车的排气系统，分别采用卡箍连接和常规焊接两种连接方式。

(Diameter of 25mm and 32mm)These two sizes flexible pipes are suitable for the mini car and Bicycle city exhaust systems .It can be used via clamp connection and conventional welding connection.

Interlock



Type: Angle type

Diameter: $\phi 38$ ---- $\phi 127$

Thickness: 0.2mm - 0.35mm

Length: At customer's request

Features

Absorbs movements in axial, lateral and angular directions. Provide resistance to torsion. Absorbs larger displacement. Can be adopted and installed to specific application.

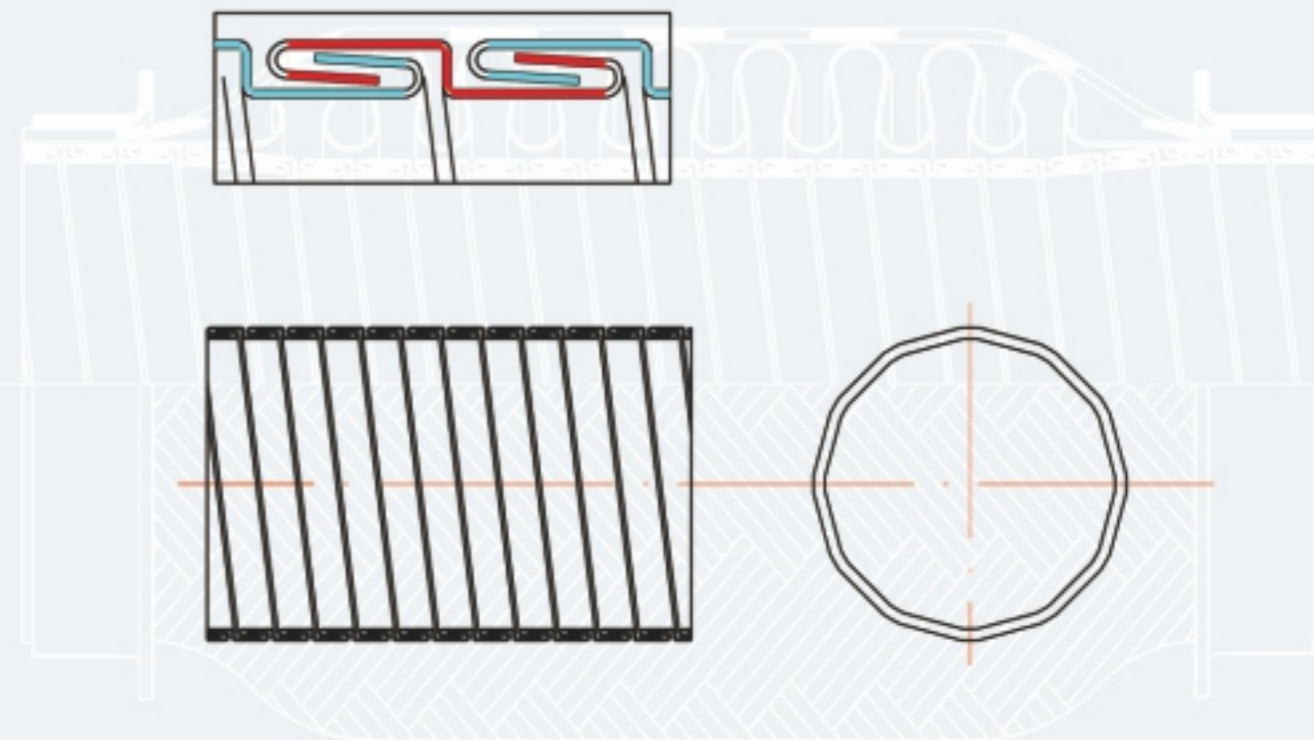

Other Products



特殊接管 REDUCER NIPPLE



带法兰挠性管 FLEX PIPE WITH FLANGE



金属软管 METAL HOSE



常用挠性管



船用波纹管 MARINE BELLOW



加油机波纹管 TANKER BELLOW



卡车排气管 TRUCK FLEXIBLE PIPE

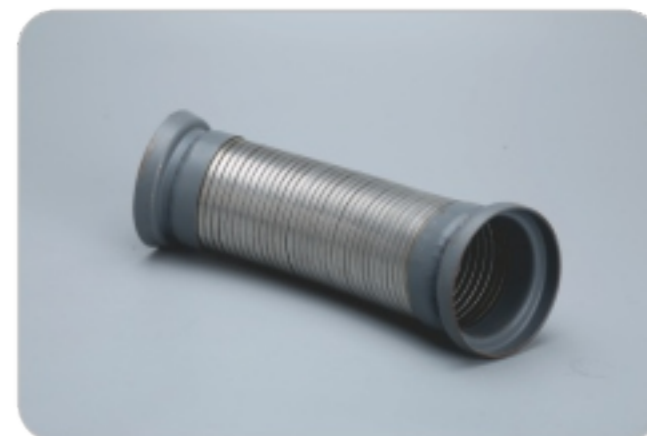

奔驰车排气管 BENZ PIPE



卡箍 CLAMP



通用补偿器 EXPANSION JOINT



波纹管 BELLOW

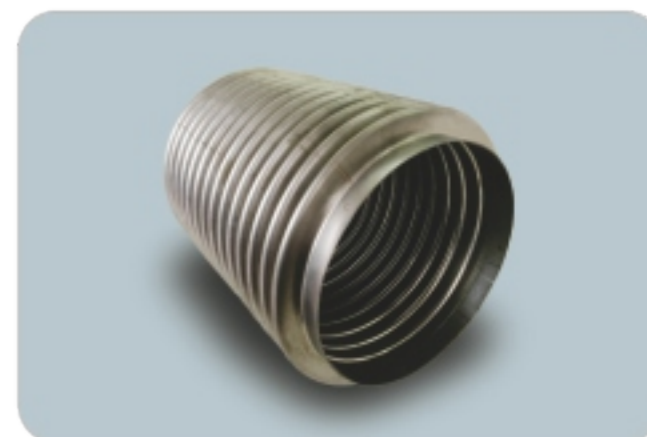

大通径波纹管 big diameter 5" ,6" ,8" etc

We have a production team of hundreds of individuals who work hard to create high quality items that are meant to last. Durability is a top focus and our employees have been trained to ensure they know exactly what needs to be done to produce all of the products that we have available. We take pride in our work and so does each and every one of the employees within our Production Department.



Our technical department is responsible for ensuring that the technical components are present. They are also responsible for research and development to learn about new materials and practices that can provide benefit to what we do here. We are dedicated to providing the best products on the market and could not do this if it weren't for the hard work from this department. They are responsible for a lot and maintain our brand's reputation.

Our Quality Control department is responsible for looking at all that is produced. This ensures that nothing of a sub quality goes out to our clients. This is a step we take to ensure we are delivering only the best to our clients, and a step that we feel is absolutely necessary. It also provides peace of mind to all who orders from us.