

GUANGLI MACHINERY

www.gongly.com



Guangli Machinery (Xinhui) Co., Ltd
Address: Dayuanshan Industrial Zone,
Gujing Town, Xinhui District,
Jiangmen City,
Guangdong Province, China.
Tel: +86-750-6280988
Fax: +86-750-6119118
Postcode: 529145
E-mail: info@gongly.com
Websites: www.gongly.com

Ice Cream Machine

ICE CREAM ROLLS

GONGGLYTM
GONGGLY MACHINE



RoHS

通过 ISO 9001:2000 国际质量体系认证 (证书编号: 15117)

www.gongly.com
Guangli Machinery (Xinhui) CO., Ltd



TM

Ice Cream Machine



C713A



C713B



BQL-S33A



BQL-S33B



BQL-S22C



BQL-838G



BQL-S33



BQL-S36



BQL-S33-2



BQL-S33-3



BQL-838



BQL-S33G



BQL-A33



BQL-S33E



BQL-838E



BQL-838F



BQL-A22



BQL-838C



BQL-H18S



BQL-H28S



BQL-A11-1



BQL-A11-2



838Y



C723



BQL-808-1



PL-18L



B6-01



CB-1000



CB 900S



CB 1+6S



CB 1+6



CB 2+10



CB-500



CB-500S



CB-900



CB 1+6G



CB-700



CB 2+10S



C713 Soft serve Freezer

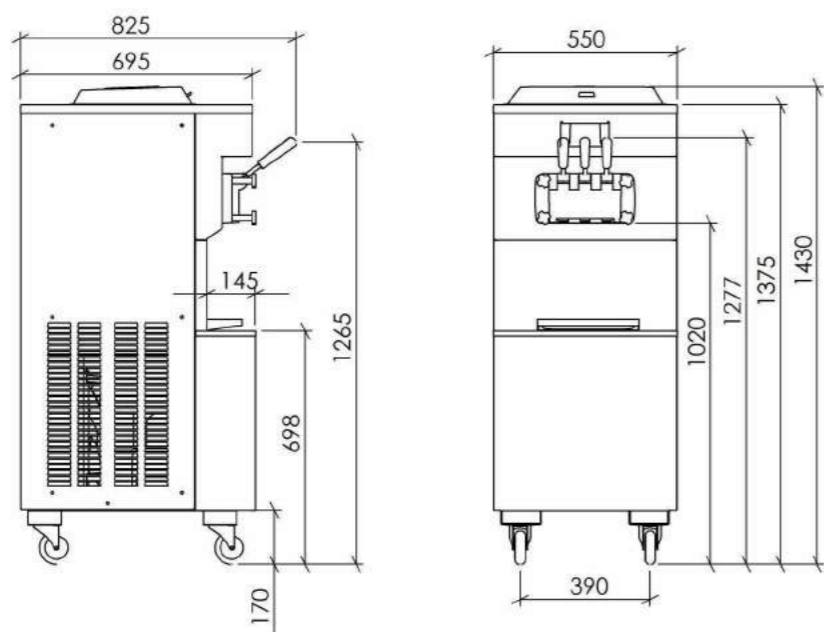

Weights	kgs
Weights	160
Dimensions	mm.
Width	550
Depth	695
Height	1430
Floor Clearance	170

Specifications Electrical

Two dedicated electrical connections are required. See the Electrical chart for the proper electrical requirements. Manufactured to be permanently connected. Consult your local Taylor distributor for cord & receptacle specifications as local codes allow.

Beater Motor
1.5 HP.

Refrigeration System
9,500 BTU/hr. R404A.
Separate Hopper Refrigeration (SHR), One, 400 BTU/hr. R134a. (BTUs may vary depending on compressor used.)

Air Cooled
Minimum 3"(76 mm) around all sides. Install the deflector provided to prevent recirculation of warm air. Minimum air clearances must be met to assure adequate air flow for optimum performance.

- Options**
- Cone Dispenser
 - Drain Adaptor (for ease of rinsing & cleaning)
 - Draw Valve Lock Kit
 - Faucet
 - Hopper Locks
 - Hopper Agitators
 - Panel Spinner
 - Syrup Rail (Integrated)
 - Syrup Rail Kit (side mount)



C713A



C713 Soft Serve Freezer
Twin Twist

Features

Offer all the popular soft serve variations from low or nonfat ice creams to custards, yogurt and sorbet. Serve two separate soft serve flavors.

Freezing Cylinder
3.4 quart (3.2 liter)

Air Pump

The pump with high overrun, Enhance the taste being tender, lower raw material cost, Increase profits.

Indicator Lights

Digital readout displays hours since last brush cleaning to assure product safety. Mix Low light alerts operator to add mix. Audible alarm may be enabled to sound when mix is low. When the Mix Out light flashes, the unit shuts down automatically to prevent damage.

Touch Screen Controls

Microprocessor touch controls are embedded in durable tempered glass panel. Multiple languages are selectable. Viscosity is continually measured to dispense consistent quality soft serve desserts. Temperatures in the hoppers or freezing cylinders may be displayed at any point of operation, in either Fahrenheit or Celsius. Draw counter allows operator to view number of servings dispensed.

Standby

During long no-use periods, the standby feature maintains safe product temperatures in the mix hopper and freezing cylinder.

C713B



C713C



www.gonggly.com



www.gonggly.com



C723 Soft serve Freezer

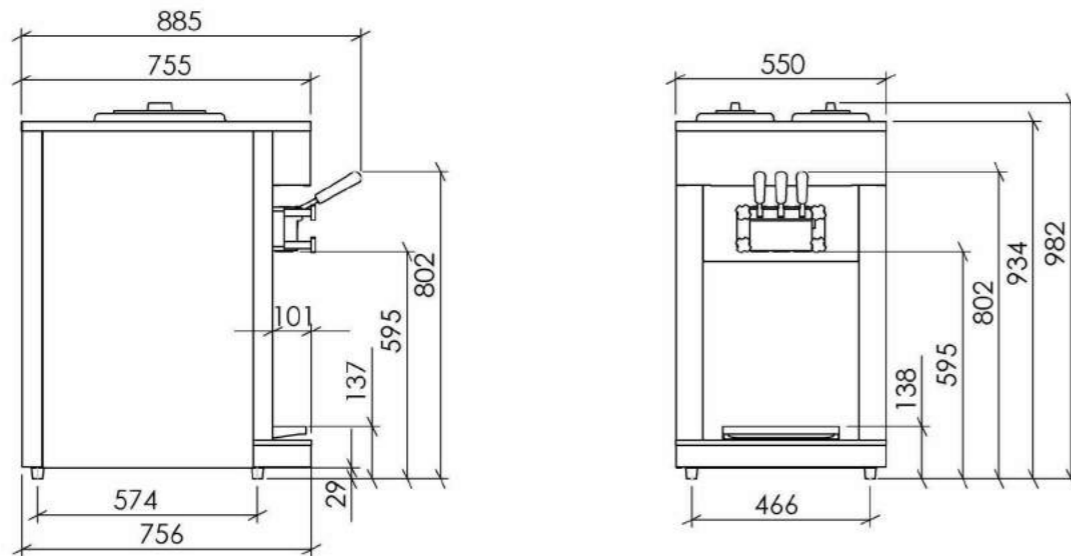

Weights	kgs
Weights	120
Dimensions	mm.
Width	550
Depth	755
Height	982
Floor Clearance	29

Specifications Electrical

Two dedicated electrical connections are required. See the Electrical chart for the proper electrical requirements. Manufactured to be permanently connected. Consult your local Taylor distributor for cord & receptacle specifications as local codes allow.

Beater Motor

1.5 HP.

Refrigeration System

9,500 BTU/hr. R404A. Separate Hopper Refrigeration (SHR), One, 400 BTU/hr. R134a. (BTUs may vary depending on compressor used.)

Air Cooled

Minimum 3"(76 mm) around all sides. Install the deflector provided to prevent recirculation of warm air. Minimum air clearances must be met to assure adequate air flow for optimum performance.

Options

- Cone Dispenser
- Drain Adaptor (for ease of rinsing & cleaning)
- Draw Valve Lock Kit
- Faucet
- Hopper Locks
- Hopper Agitators
- Panel Spinner
- Syrup Rail (Integrated)
- Syrup Rail Kit (side mount)

Bidding Specs			
Electrical: Volt	Hz	Ph	
Neutral: <input type="checkbox"/> Yes <input type="checkbox"/> No			



www.gongly.com



C723 Soft Serve Freezer

Features

Offer all the popular soft serve variations from low or nonfat ice creams to custards, yogurt and sorbet. Serve two separate soft serve flavors.

Freezing Cylinder

3.4 quart (3.2 liter)

Air Pump

The pump with high overrun, Enhance the taste being tender, lower raw material cost, Increase profits.

Indicator Lights

Digital readout displays hours since last brush cleaning to assure product safety. Mix Low light alerts operator to add mix. Audible alarm may be enabled to sound when mix is low. When the Mix Out light flashes, the unit shuts down automatically to prevent damage.

Touch Screen Controls

Microprocessor touch controls are embedded in durable tempered glass panel. Multiple languages are selectable. Viscosity is continually measured to dispense consistent quality soft serve desserts. Temperatures in the hoppers or freezing cylinders may be displayed at any point of operation, in either Fahrenheit or Celsius. Draw counter allows operator to view number of servings dispensed.

Standby

During long no-use periods, the standby feature maintains safe product temperatures in the mix hopper and freezing cylinder.



304 Stainless steel beater
More overrun



通过 ISO 9001:2000 国际质量体系认证 (证书编号: 15117)

www.gongly.com

*2012 Top model
Italian Style*



BQL-S33A

ICE-CREAM MACHINE

MAIN POWER:	220V / 110V 50Hz / 60Hz
RATE POWER:	3.0kw
REFRIGERANT:	R22 / R404A
PRODUCTION:	35-40L/h
DIMENSIONS:	540x770x1480mm
N.W.:	160kg



BQL-S33B

ICE-CREAM MACHINE

MAIN POWER:	220V / 110V 50Hz / 60Hz
RATE POWER:	3.0kw
REFRIGERANT:	R22 / R404A
PRODUCTION:	35-40L/h
DIMENSIONS:	540x770x1480mm
N.W.:	160kg

BQL-S33E

ICE-CREAM MACHINE

MAIN POWER:	220V / 50Hz / 60Hz
RATE POWER:	2.4kw
REFRIGERANT:	R22 / R404A
PRODUCTION:	22-28kg/h 28-38L/h
DIMENSIONS:	540x770x1480(mm)
N.W.:	160kg



BQL-S33F

ICE-CREAM MACHINE

MAIN POWER:	220V / 50Hz / 60Hz
RATE POWER:	2.4kw
REFRIGERANT:	R22 / R404A
PRODUCTION:	22-28kg/h 28-38L/h
DIMENSIONS:	540x770x1480(mm)
N.W.:	160kg





BQL-S33G

ICE-CREAM MACHINE

MAIN POWER:	220V 50Hz / 60Hz
RATE POWER:	2.4kw
REFRIGERANT:	R22 / R404A
PRODUCTION:	40-55L/h
DIMENSIONS:	540x770x1480(mm)
N.W.:	165kg

304 Stainless steel beater
More overrun

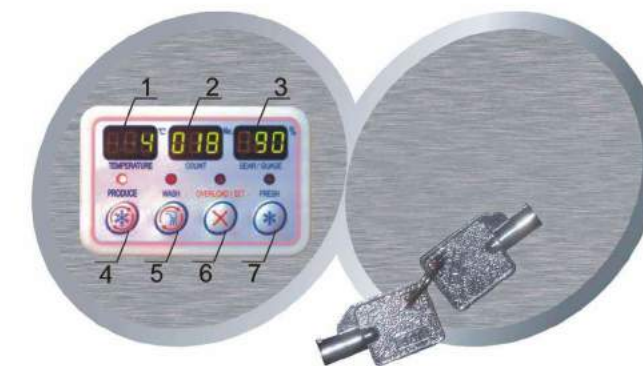

CONTROL PANEL:

- Indicator shows the refrigerating temperature/ Adjust the temperature between +1°C to 10°C
- Counter Indicator/Lack material alarm
- Indicator shows the percentage of the produce process/shows the motor current
- Produce Switch
- Wash Switch
- Overload Reset Switch/Ice Cream Hardness adjustment
- Keep Fresh/ pre-cooling switch, Ice Cream Hardness adjustment.

DOUBLE AIR PUMPS:

- ※Full automatic double air pumps designed to inlet more air.
- ※Feed system control by electronic valve.
- ※Exhaust pipes exhaust air automatically.
- ※High over-run rate up to 80%~100%.
- ※The refrigerating quicker than common machine 40%, and saves 40%-50% material.

COUNTER INDICATOR:

- ※Calculate how many cups ice cream have sold
- ※The number of discharged ice cream shows on the counter indicator.
- ※Good for Management , with the certain key to reset the indicator back to "000"

ACCESSORIAL PART:

- ※Canopy
- ※Cone Holder
- ※Serving Table



BQL-S22-1 BQL-S33-1 BQL-S48-1 BQL-S36

ICE-CREAM MACHINE	ICE-CREAM MACHINE	ICE-CREAM MACHINE	ICE-CREAM MACHINE
MAIN POWER: 220V / 110V 50Hz / 60Hz	MAIN POWER: 220V / 50Hz / 60Hz	MAIN POWER: 380V / 50Hz / 60Hz	MAIN POWER: 220V / 50Hz / 60Hz
RATE POWER: 1.7kw	RATE POWER: 2.4kw	RATE POWER: 4.2kw	RATE POWER: 2X1.7kw
REFRIGERANT: R22 / R404A	REFRIGERANT: R22 / R404A	REFRIGERANT: R22 / R404A	REFRIGERANT: R22 / R404A
PRODUCTION: 11-16kg/h 18-25L/h	PRODUCTION: 22-28kg/h 28-38L/h	PRODUCTION: 26-36kg/h 40-55L/h	PRODUCTION: 24-34kg/h 36-44L/h
DIMENSIONS: 540x770x1480(mm)	DIMENSIONS: 540x770x1480(mm)	DIMENSIONS: 540x770x1480(mm)	DIMENSIONS: 540x770x1480(mm)
N.W.: 145kg	N.W.: 160kg	N.W.: 165kg	N.W.: 210kg





BQL-S22-2
BQL-S33-2
BQL-S48-2

ICE-CREAM MACHINE

MAIN POWER:	220V/110V 50Hz/60Hz
	220V 50Hz / 60Hz
	380V 50Hz / 60Hz
RATE POWER:	1.7kw
	2.4kw
	4.2kw
REFRIGERANT:	R22 / R404A
	R22 / R404A
	R22 / R404A
PRODUCTION:	11-16kg/h 18-25L/h
	22-28kg/h 28-38L/h
	26-36kg/h 40-55L/h
DIMENSIONS:	540x770x1480(mm)
	540x770x1480(mm)
	540x770x1480(mm)
N.W.:	145kg
	160kg
	165kg



BQL-A33
ICE-CREAM MACHINE

MAIN POWER:	220V 50Hz/60Hz
RATE POWER:	2.4kw
REFRIGERANT:	R22 / R404A
PRODUCTION:	24-34kg/h 36-44L/h
DIMENSIONS:	705x770x1480(mm)
N.W.:	172kg



BQL-S33
RAINBOW ICE CREAM MACHINE

MAIN POWER:	220V / 110V 50Hz / 60Hz
RATE POWER:	2.4kw
REFRIGERANT:	R22 / R404A
PRODUCTION:	40-55L/h
DIMENSIONS:	540x770x1480(mm)
N.W.:	165kg

BQL-S33-3
BQL-S48-3

ICE-CREAM MACHINE

MAIN POWER:	220V 50Hz / 60Hz
	380V 50Hz / 60Hz
RATE POWER:	2.4kw
	4.2kw
REFRIGERANT:	R22 / R404A
	R22 / R404A
PRODUCTION:	22-28kg/h 28-38L/h
	26-36kg/h 40-55L/h
DIMENSIONS:	540x770x1480(mm)
	540x770x1480(mm)
N.W.:	160kg
	165kg



304 Stainless steel beater
More overrun



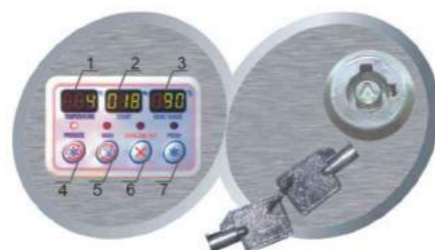

BQL-S22C
ICE-CREAM MACHINE

MAIN POWER:	220V / 110V 50Hz / 60Hz
RATE POWER:	1.7kw
REFRIGERANT:	R22 / R404A
PRODUCTION:	18-25 L/h
DIMENSIONS:	540x740x1480(mm)
N.W.:	145kg



BQL-838G
ICE-CREAM MACHINE

MAIN POWER:	220V / 110V 50Hz / 60Hz
RATE POWER:	1.7kw
REFRIGERANT:	R22 / R404A
PRODUCTION:	11 - 16kg /h 18-25L /h
DIMENSIONS:	518x740x1310(mm)
N.W.:	135kg



BQL-838E
ICE-CREAM MACHINE

MAIN POWER:	220V / 110V 50Hz / 60Hz
RATE POWER:	1.7kw
REFRIGERANT:	R22 / R404A
PRODUCTION:	11 - 16kg /h 18-25L /h
DIMENSIONS:	518x740x1310(mm)
N.W.:	135kg

BQL-838F
ICE-CREAM MACHINE

MAIN POWER:	220V / 110V 50Hz / 60Hz
RATE POWER:	1.7kw
REFRIGERANT:	R22 / R404A
PRODUCTION:	11 - 16kg /h 18-25L /h
DIMENSIONS:	518x740x1310(mm)
N.W.:	135kg





BQL-838
ICE-CREAM MACHINE

MAIN POWER:	220V / 110V 50Hz / 60Hz
RATE POWER:	1.7kw
REFRIGERANT:	R22 / R404A
PRODUCTION:	11 - 16kg /h 18-25L /h
DIMENSIONS:	518x740x1310(mm)
N.W.:	135kg



BQL-838A
ICE-CREAM MACHINE

MAIN POWER:	220V / 110V 50Hz / 60Hz
RATE POWER:	1.7kw
REFRIGERANT:	R22 / R404A
PRODUCTION:	11 - 16kg /h 18-25L /h
DIMENSIONS:	518x740x1310(mm)
N.W.:	135kg



BQL-838C
ICE-CREAM MACHINE

MAIN POWER:	220V / 110V 50Hz / 60Hz
RATE POWER:	1.7kw
REFRIGERANT:	R22 / R404A
PRODUCTION:	11 - 16kg /h 18-25L /h
DIMENSIONS:	518x740x1310(mm)
N.W.:	135kg



BQL-808-1
ICE-CREAM MACHINE

MAIN POWER:	220V / 110V 50Hz / 60Hz
RATE POWER:	1.7kw
REFRIGERANT:	R22 / R404A
PRODUCTION:	11 - 16kg /h 18-25L /h
DIMENSIONS:	518x740x780(mm)
N.W.:	108kg

BQL-808-2
ICE-CREAM MACHINE

MAIN POWER:	220V / 110V 50Hz / 60Hz
RATE POWER:	1.7kw
REFRIGERANT:	R22 / R404A
PRODUCTION:	11 - 16kg /h 18-25L /h
DIMENSIONS:	518x740x780(mm)
N.W.:	108kg



BQL-A11-1
ICE-CREAM MACHINE

MAIN POWER:	220V 50Hz / 60Hz
RATE POWER:	1.1kw
REFRIGERANT:	R22 / R404A
PRODUCTION:	8-11kg/h 13-18 L/h
DIMENSIONS:	422x592x622(mm)
N.W.:	59kg



BQL-A22

3 DIFFERENT COLOURS BODY FOR CUSTOMER CHOICE

ICE-CREAM MACHINE

MAIN POWER:	220V/110V 50Hz/60Hz
RATE POWER:	1.7kw
REFRIGERANT:	R22 / R404A
PRODUCTION:	11-16kg/h 18-25L/h
DIMENSIONS:	540x770x1480(mm)
N.W.:	135kg



BQL-838Y
ICE-CREAM MACHINE

MAIN POWER:	220V / 110V 50Hz / 60Hz
RATE POWER:	1.7kw
REFRIGERANT:	R22 / R404A
PRODUCTION:	11 - 16kg /h 18-25L /h
DIMENSIONS:	550x885x1480mm
N.W.:	145kg



BQL-A11-2
ICE-CREAM MACHINE

MAIN POWER:	220V 50Hz / 60Hz
RATE POWER:	1.1kw
REFRIGERANT:	R22 / R404A
PRODUCTION:	8-11kg/h 13-18 L/h
DIMENSIONS:	422x692x622(mm)
N.W.:	59kg

OPTIONS COLOUR : GREEN, RED, YELLOW.

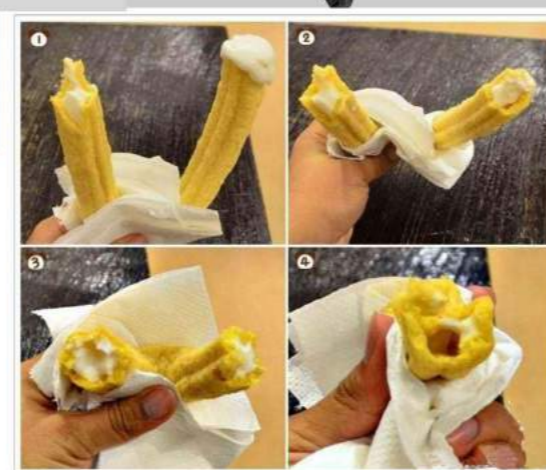

Ice Cream In side Cookie



BQL-G22
ICE-CREAM MACHINE

MAIN POWER:	220V / 110V 50Hz / 60Hz
RATE POWER:	1.7kw
REFRIGERANT:	R22 / R404A
PRODUCTION:	11 - 16kg /h 18-25L /h
DIMENSIONS:	550x885x1480mm
N.W.:	145kg



PL-18L (Cool & hot)
JUICE DISPENSER

PRODUCTION:	2 x 18L / 3 x 18L
MAIN POWER:	220V 50Hz / 60Hz
RATE POWER:	455W/680W
REFRIGERANT:	500x386x728(mm)
DIMENSIONS:	R22



PL-18L (Cool & hot)
JUICE DISPENSER

PRODUCTION:	2 x 18L / 3 x 18L
MAIN POWER:	220V 50Hz / 60Hz
RATE POWER:	455W/680W
REFRIGERANT:	500x386x728(mm)
DIMENSIONS:	R22



G10L2S
SLUSH FREEZER

PRODUCTION:	7x 2L
MAIN POWER:	220V 50Hz / 60Hz
RATE POWER:	1.1kw
REFRIGERANT:	R22 / R134A
DIMENSIONS:	365x500x700 (mm)



G10L3S
SLUSH FREEZER

PRODUCTION:	7 x 3L
MAIN POWER:	220V 50Hz / 60Hz
RATE POWER:	1.4kw
REFRIGERANT:	R22 / R134A
DIMENSIONS:	365x720x700 (mm)



G10L2
SLUSH FREEZER

PRODUCTION:	15 x 2L
MAIN POWER:	220V 50Hz / 60Hz
RATE POWER:	1.1kw
REFRIGERANT:	R22 / R134A
DIMENSIONS:	480x625x835 (mm)



G10L3
SLUSH FREEZER

PRODUCTION:	15 x 3L
MAIN POWER:	220V 50Hz / 60Hz
RATE POWER:	1.4kw
REFRIGERANT:	R22 / R134A
DIMENSIONS:	680x625x835 (mm)



ST-30
ICE-CREAM CONE MACHINE

PRODUCTION:	500-900pcs/h
HEATING:	Electric heating
RATE POWER:	14KW
THE MOLD OPENS TO SHUT FORM:	Manual
AIR-PUMP WIND POWER PRESS:	0.5MPa
SUPPLY FEEDING MATERIAL MODE:	Semiautomatic
BAKE PRODUCTION PER:	30 pcs
BAKE TIME:	1-2 min
MACHINE DIMENSIONS:	1400 x 1000 x 1500(mm)
NET WEIGHT:	670kg



B-12
ICE-CREAM DISPLAY

WORKING TEMP:	-15~-18℃
POWER:	220V/50Hz/60Hz
RATE POWER:	0.23kw
REFRIGERANT:	R134A/150g
DIMENSIONS:	1230*830*1290mm
12 SQUARE TRAYS SINGLE-STORY DOUBLE-RANK	
TRAY DIMENSIONS:	265*165*100 mm



H18S

BATCH FREEZER

MAIN POWER:	110V / 220V 50Hz / 60Hz
RATE POWER:	1.7kw
REFRIGERANT:	R22 / R404A
PRODUCTION:	22- 28kg/h 28-38 L /h
DIMENSIONS:	518x740x1240(mm)
N.W.:	138kg



H28S

BATCH FREEZER

MAIN POWER:	220V / 380V 50Hz / 60Hz
RATE POWER:	3.4kw
REFRIGERANT:	R22 / R404A
PRODUCTION:	26- 40kg/h 40-58L /h
DIMENSIONS:	540x770x1480(mm)
N.W.:	168kg



H18S-2

BATCH FREEZER

MAIN POWER:	110V / 220V 50Hz / 60Hz
RATE POWER:	1.8kW
REFRIGERANT:	R22 / R404A
PRODUCTION:	28-38L/h
DIMENSIONS:	518x740x860mm
N.W.:	105kg



H18S-3

BATCH FREEZER

MAIN POWER:	110V / 220V 50Hz / 60Hz
RATE POWER:	1.3kW
REFRIGERANT:	R22 / R404A
PRODUCTION:	10-15L/h
DIMENSIONS:	400x600x600mm
N.W.:	54kg



ZSG-1.0

BATCH FREEZER

MAIN POWER:	110V / 220V 50Hz / 60Hz
RATE POWER:	170W
REFRIGERANT:	R134a
PRODUCTION:	8x 5L
DIMENSIONS:	1000x680x1230mm
N.W.:	70kg



H18S-1

BATCH FREEZER

MAIN POWER:	110V / 220V 50Hz / 60Hz
RATE POWER:	2.4kW
REFRIGERANT:	R22 / R404A
PRODUCTION:	35-50L/h
DIMENSIONS:	518x740x1240(mm)
N.W.:	138kg



MC-01

ICE CREAM MCFLURRY

MAIN POWER:	110V / 220V 50Hz / 60Hz
RATE POWER:	10W
DIMENSIONS:	400x300x680mm
PACKAGING:	440x340x720mm
N.W.:	14kg
G.W.:	15kg





PM-01

POPSICLE MACHINE

Model	PM-01		
Main power	220V50Hz/60Hz 110V/60Hz		
Rated output	1.2kW		
Refrigerant	R22/R404A		
Production capacity	3000pcs/day		
N.W.	75kg	G.W.	90kg
Overall dimensions	555x555x1240mm		
Packing dimensions	700x700x1380mm		



PM-03

POPSICLE MACHINE

Model	PM-03		
Main power	220v-250V /50Hz		
Rated output	2.5kW		
Refrigerant	R22/R404A		
Production capacity	10000pcs/day		
N.W.	130kg	G.W.	178kg
Overall dimensions	995x555x1240mm		
Packing dimensions	1085x700x1380mm		



PM-02

POPSICLE MACHINE

Model	PM-02(holds 2 molds)		
Main power	220V50Hz/60Hz 110V/60Hz		
Rated output	1.9kW		
Refrigerant	R22/R404A		
Production capacity	8000pcs/day		
N.W.	110kg	G.W.	130kg
Overall dimensions	825x555x1240mm		
Packing dimensions	975x700x1380mm		



PM-04

POPSICLE MACHINE

Model	PM-04		
Main power	220V50Hz/60Hz 110V/60Hz		
Rated output	3.0kW		
Refrigerant	R404A		
Production capacity	16000pcs/day		
N.W.	210kg	G.W.	245kg
Overall dimensions	1220x655x1375mm		
Packing dimensions	1365x800x1480mm		





BBJ-1

POPSICLE MACHINE

Model	BBJ-1		
Main power	220v-250V /50Hz		
Rated output	1. 15kW		
Refrigerant	R22/R410A		
Production capacity	120pcs/hour		
N.W.	60kg	G.W.	70kg
Overall dimensions	720x520x775mm		
Packing dimensions	760x560x900mm		



CBJ-1x6

FRIED ICE CREAM MACHINE

Model	CBJ-1x6		
Main power	220V50/60Hz 110V60Hz		
Rated output	0. 74kW		
Refrigerant	R22		
Ice Pan dimensions	360x20mm		
N.W.	45kg	G.W.	55kg
Overall dimensions	620x515x750mm		
Packing dimensions	700x595x900mm		



BBJ-2

POPSICLE MACHINE

Model	BBJ-2		
Main power	220v-250V /50Hz		
Rated output	1. 15kW		
Refrigerant	R22/R410A		
Production capacity	120pcs/hour		
N.W.	60kg	G.W.	70kg
Overall dimensions	720x520x775mm		
Packing dimensions	760x560x900mm		



CBJ-D2x5

FRIED ICE CREAM MACHINE

Model	CBJ-D2x5		
Main power	220V50/60Hz 110V60Hz		
Rated output	1. 06kW		
Refrigerant	R22		
Ice Pan dimensions	360x360x20mm		
N.W.	45kg	G.W.	55kg
Overall dimensions	920x620x790mm		
Packing dimensions	1000x700x960mm		



CB-500
FRIED ICE CREAM MACHINE

Model	CB-500		
Main power	220V50/60Hz 110V60Hz		
Rated output	1.2kW		
Refrigerant	R22/R134A/R404A		
Ice Pan dimensions	450x20mm		
N.W.	60kg	G.W.	78kg
Overall dimensions	650x650x800mm		
Packing dimensions	760x760x950mm		



CB-500S
FRIED ICE CREAM MACHINE

Model	CB-500S		
Main power	220V50/60Hz 110V60Hz		
Rated output	1.5kW		
Refrigerant	R404A		
Ice Pan dimensions	500x500x20mm		
N.W.	73kg	G.W.	98kg
Overall dimensions	650x650x800mm		
Packing dimensions	760x760x950mm		



CB 1+6
FRIED ICE CREAM MACHINE

Model	CB 1+6		
Main power	220V50/60Hz 110V60Hz		
Rated output	1.5kW		
Refrigerant	R22/R134A/R404A		
Ice Pan dimensions	480mm		
6 pcs tanks temp.	+10°C		
N.W.	75kg	G.W.	100kg
Overall dimensions	1100x650x800mm		
Packing dimensions	1210x760x950mm		



CB 1+6 G
FRIED ICE CREAM MACHINE

Model	CB 1+6 G		
Main power	220V50/60Hz 110V60Hz		
Rated output	1.5kW		
Refrigerant	R22/R134A/R404A		
Ice Pan dimensions	480mm		
6 pcs tanks temp.	+10°C		
N.W.	75kg	G.W.	100kg
Overall dimensions	1100x650x800mm		
Packing dimensions	1210x760x950mm		





CB 2+10

FRIED ICE CREAM MACHINE



Model	CB 2+10		
Main power	220V50/60Hz 110V60Hz		
Rated output	2.8kW		
Refrigerant	R22/R134A/R404A		
Ice Pan dimensions	480mm*2		
10 pcs tanks temp.	+10°C		
N.W.	135kg	G.W.	180kg
Overall dimensions	1847x650x800mm		
Packing dimensions	2000x760x950mm		



CB 2+10S

FRIED ICE CREAM MACHINE



Model	CB 2+10S		
Main power	220V50/60Hz 110V60Hz		
Rated output	3.2kW		
Refrigerant	R404A		
Ice Pan dimensions	500x500mm*2		
10 pcs tanks temp.	+10°C		
N.W.	155kg	G.W.	195kg
Overall dimensions	1847x650x800mm		
Packing dimensions	2000x760x950mm		



CB-900
FRIED ICE CREAM MACHINE

Model	CB-900		
Main power	220V50/60Hz 110V60Hz		
Rated output	2.6kW		
Refrigerant	R22/R134A/R404A		
Ice Pan dimensions	480mm		
N.W.	80kg	G.W.	105kg
Overall dimensions	1100x650x800mm		
Packing dimensions	1210x760x950mm		



CB-1000
FRIED ICE CREAM MACHINE

Model	CB-1000		
Main power	220V50/60Hz 110V60Hz		
Rated output	2.2kW		
Refrigerant	R22/R134A/R404A		
Marble slab thickness	1090x560x20mm		
N.W.	90kg	G.W.	110kg
Overall dimensions	1090x560x710mm		
Packing dimensions	1150x620x840mm		



CB-700
FRIED ICE CREAM MACHINE

Model	CB-700		
Main power	220V50/60Hz 110V60Hz		
Rated output	2.0kW		
Refrigerant	R22/R134A/R404A		
Ice Pan dimensions	700mm		
N.W.	77kg	G.W.	97kg
Overall dimensions	830x830x710mm		
Packing dimensions	890x890x840mm		



CB-900S
FRIED ICE CREAM MACHINE

Model	CB-900S		
Main power	220V50/60Hz 110V60Hz		
Rated output	1.7kW		
Refrigerant	R22/R134A/R404A		
Ice Pan dimensions	900x475mm		
N.W.	85kg	G.W.	105kg
Overall dimensions	1000x600x800mm		
Packing dimensions	1050x650x830mm		

With fruit & ice cream





CB 1+6 S
FRIED ICE CREAM MACHINE

Model	CB 1+6		
Main power	220V50/60Hz 110V60Hz		
Rated output	1.5kW		
Refrigerant	R22/R134A/R404A		
Ice Pan dimensions	500x500mm		
6 pcs tanks temp.	+10°C		
N.W.	90kg	G.W.	115kg
Overall dimensions	1100x650x800mm		
Packing dimensions	1210x760x950mm		

Displayer

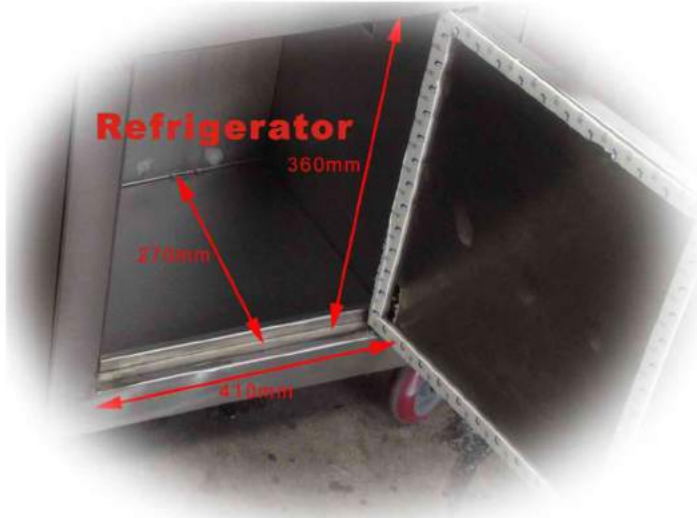

PZ-04
PIZZA CONE MACHINE

Model	PZ-04
Main power	220V50/60Hz 110V60Hz
Rated output	2.4kW
Capacity	160pcs/hr
Rated Current	12A
Size	530x360x1050mm
N.W.	43kg



PO-10A
PIZZA OVEN

Model	PZ-04
Main power	220V50/60Hz 110V60Hz
Rated output	2.0kW
Capacity	160pcs/hr
Rated Current	10A
Size	720x610x600mm
N.W.	28kg

Generator



Mobile ice cream cart

Not including the equipments

DIMENSIONS: 1500x800x2060mm

Gasoline Generator Power: 3.0kW



Ice cream car of a complete set of equipment includes: the car, umbrella, a hard ice cream machine, make-up machine, ice cream freezer box, 15pcs import condensing agent, 100pcs embossing box, 2 pieces of the 12 v battery, a set of charger, the blender and scoop.

Mobile ice cream cart

1. The material into the hard ice cream machine mixing, puffing
2. Making good ice cream into the forming mold case
3. Put the mould in the freezer refrigeration
4. Making the fancy ice cream by ice cream machine
5. Complete



spaghetti ice cream maker



BQL-150A

Spaghetti ice cream maker

MAIN POWER: AC220V/DC24V

RATE POWER: 120W

DIMENSIONS: 400x400x1000mm

N.W.: 20kg

Ice cream light box

MAIN POWER: 220V / 110V 50Hz / 60Hz

RATE POWER: 40W

DIMENSIONS: 1610x530mm

N.W.: 9kg

Multicolor 12 colors



SOFT ICE CREAM MACHINE



**Worm Reducer
without belts and wheels**

ICE CREAM MACHINE

Model	BQL-S33W
Main power	220V50/60Hz
Rated output	3.0kW
Refrigerant	R404A/R134A
Production	50-60L/h
N.W.	210kg
Overall dimensions	587x818x1540mm

SOFT ICE CREAM MACHINE



**Double Worm Reducer
without belts and wheels**

ICE CREAM MACHINE

Model	BQL-S36W
Main power	220V50/60Hz
Rated output	3.0kW
Refrigerant	R404A/R134A
Production	50-60L/h
N.W.	240kg
Overall dimensions	650x925x1540mm

SOFT ICE CREAM MACHINE



**Worm Reducer
without belts and wheels**

ICE CREAM MACHINE

Model	BQL-A11W
Main power	220V50/60Hz 110V60Hz
Rated output	1.5kW
Refrigerant	R404A/R134A
Production	18-25L/h
N.W.	105kg
Overall dimensions	345x925x923mm



TOPPING REFRIGERATOR



TOPPING REFRIGERATOR

Model	F-12		
Main power	220V50/60Hz 110V60Hz		
Rated output	0.3kW		
Refrigerant	R134A/R600A		
Food Tank dimensions	1/9"(12Pcs)		
N.W.	26kg	G.W.	51kg
Overall dimensions	650x650x800mm		
Packing dimensions	760x760x950mm		