



HYDR-STAR Fluid Control Company Limited

Add: Room 1710, Business-Building No.2, XiongChuYiHao, No.888, XiongChu Road, HongShan District, Wuhan City, Hubei Prov. China 430070

Tel : +86 27 66000010

E-mail: sales@hydrstar.com

Web: www.hydrstar.com

Agent :



HYDR-STAR FLUID CONTROL COMPANY LIMITED



AIR-DRIVEN LIQUID PUMPS

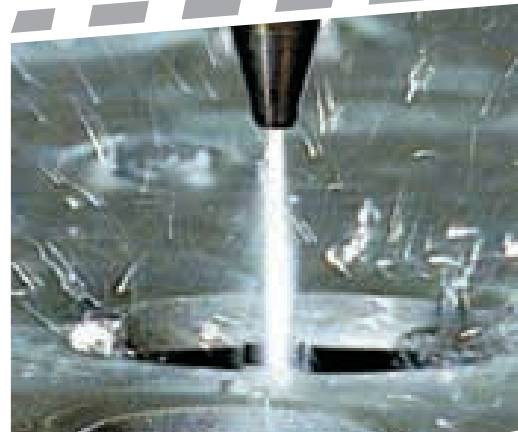

Waterjet Cutting



Aerospace



Chemical



Petro



Waterblasting



Process Controls



Automobile

HYDR-STAR's pumps and valves are widely used in various industries. We provide quality products and services with international standard for many well know and outstanding companies worldwide. Choose HYDR-STAR, we will provide you with comprehensive products and professional services.

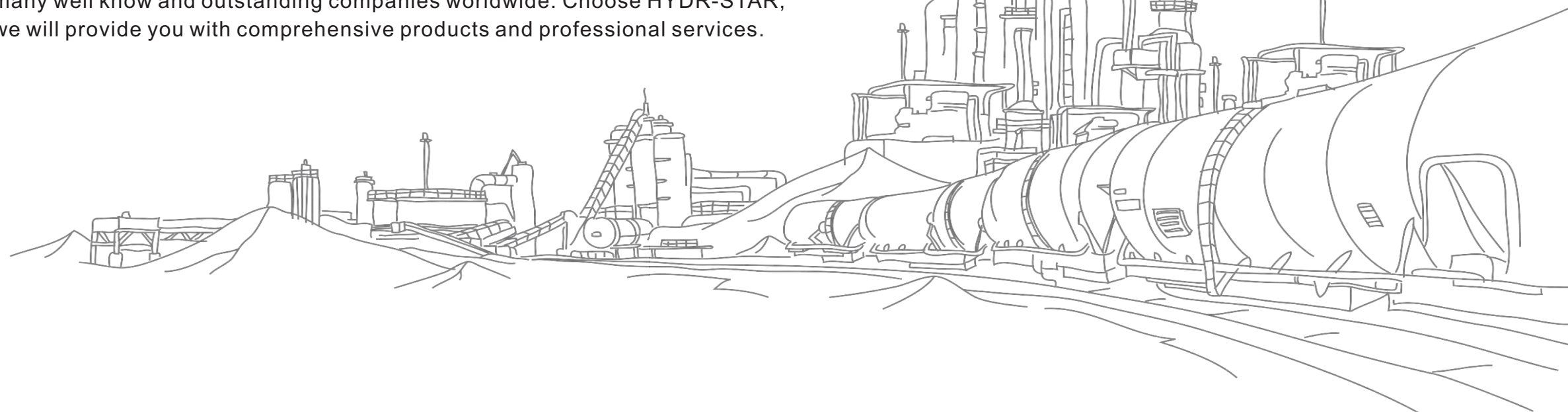

Contents

OVERVIEW	1
INTRODUCTION	3
AHP03 SERIES Single Drive Single Acting	5
AHP06 SERIES Single Drive Single Acting	7
AHP06 SERIES Double Drive Single Acting	9
AHP06 SERIES Triple Drive Single Acting	11
AHP06 SERIES Single Drive Double Acting	13
AHP06 SERIES Double Drive Double Acting	15
AHP06 SERIES Long Stroke Single Drive Double Acting	17
AHP10 SERIES Single Drive Double Acting	19
AHP10 SERIES Double Drive Double Acting	21



About HYDR-STAR

HYDR-STAR Fluid Control Company Limited specialize and focus on the R&D, design and manufacture of stainless steel instrumentation valves, high pressure valves, control valves, high pressure pumps and boosters with international standard.

The company occupies 54 acres and owns 20,000 square meters of modern workshop and office buildings; an engineering team with more than 15 years of professional fluid control technology; advanced testing and manufacturing equipment; complete quality control system; customer oriented, timely and professional sales team and superior services to provide high quality products and solutions for the global fluid control industry.

HYDR-STAR passed the ISO9001 quality management system certification and our products passes SIL and EAC certification. Our products are recognized by clients and customers in Middle East, European Union, Russia, China and other countries.

After years of hard work, HYDR-STAR has become an industry leader and has established list of regular customers from around the globe. Our products are being used in oil&gas, petrochemical, energy, mining, aerospace, military, automotive, firefighting and conventional hydraulic machinery Industries.

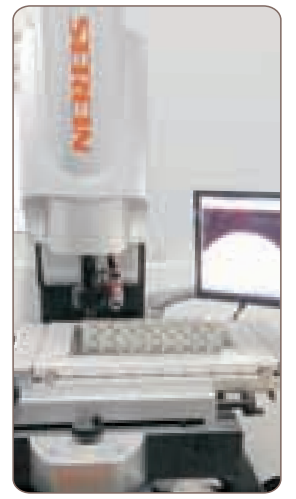

A corner of workshop

High Precision Lathe	Three Coordinate Measuring Machine
----------------------	------------------------------------

VMC	Warehouse
-----	-----------



Features

- ★ Up to 100,000 psi (7000 bar) capability.
- ★ Infinitely variable cycling speed.
- ★ Stall feature at pre-determined pressure to hold that pressure without consuming power .
- ★ Easily automated, with many modification and control options available.
- ★ Suitable for most liquids and liquefied gases.
- ★ Can be manufactured to meet CE, ATEX and NACE.

- ★ Robust, reliable, compact and easy to maintain proven design.
- ★ Unbalanced cycling spool provides immediate response to pressure changes.
- ★ Also available in standard, Configuration required by customer.
- ★ No need for air-line lubrication, which saves costs and prevents contamination.

Easy handling

1. Initial operation

The pump is prepared for operation manually:

- ★ Connect supply lines (compressed air, suction and pressure lines).
- ★ Set air drive pressure.
- ★ Open compressed air supply slowly so that the high-pressure pump starts up .

2. Build up pressure

The pump technology executes all the steps for pressure build-up automatically:

- ★ Automatic cycling of 4/2-way valve (spoolcycling valve) by means of air pulses from the pilot valve (2/2-way valve)
- ★ Suction of medium.
- ★ Optimum cycling conditions thanks to large cross-sections .

3. Achieve and hold pressure

The pump controls the processes of reaching and holding pressure.

- ★ Pump automatically stops operating when the operating pressure is reached due to equilibrium of forces
- ★ Pressure is held.
- ★ Pressure holding phase with no energy consumption or heat generation .
- ★ Pump restarted automatically if operating pressure drops .

Applications

- ★ Pressure testing
- ★ Jacking and Lifting.
- ★ Valve actuator control
- ★ Hydraulic cylinder actuation
- ★ Roller tensioning
- ★ Precision lubrication and spraying
- ★ Work holding and power clamping
- ★ Liquefied gas transfer
- ★ Machine tools
- ★ Well Control Panel

Selection

The pump model is selected according to the use requirements. Such as output pressure, output flow, medium and temperature, available air or gas drive pressure and flow. This guide will help you to pre-select the pump ideally suited for your application. If you have specific questions, Please contact us. We urge you to provide us with details of the duties you require from the pump, available air/gas drive pressure, and pressure/flow requirements, and we will recommend a model and any corresponding accessories.

The series and its functions

HYDR-STAR pumps offer the right solution for every application. They are suitable for different or stepped flow rates as well as for different maximum allowable operating pressures. HYDR-STAR pumps with two or three air drive sections reach the same final pressure as a HYDR-STAR pump with one air drive section with 1/2 or 1/3 of the air drive. Double-acting pumps increase the pump capacity by around 50% in comparison to single-acting pumps and reduce the pulsation equally.

The following model variants are available depending on the series:

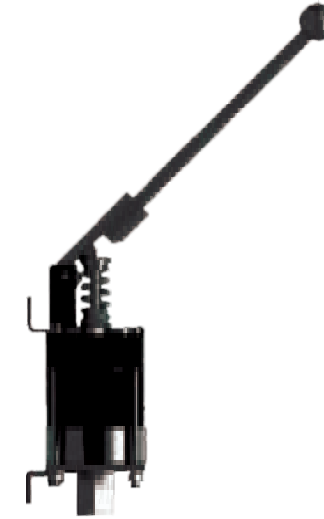

Pumps With Handle

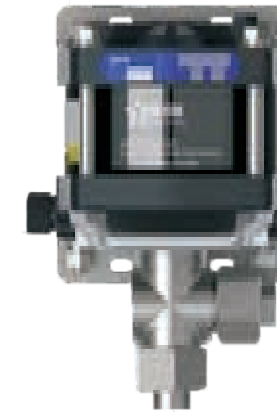

Angular Pumps

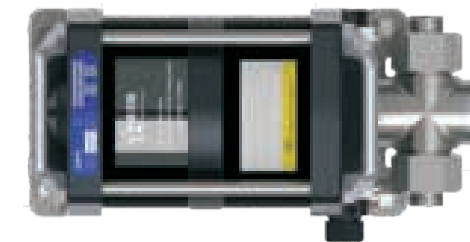

Double Air Drive, Single Acting

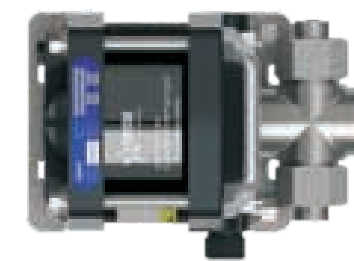

Single Air Drive, Single Acting

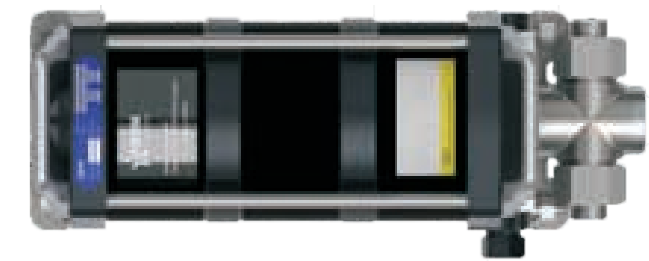

Triple Air Drive, Single Acting

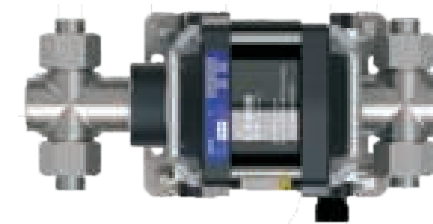

Single Air Drive, Double Acting

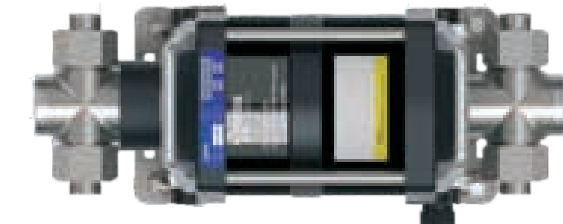

Double Air Drive, Double Acting



AHP03 Series

Single Drive Single Acting

Features

- ★ Choice of 9 ratios.
- ★ Flows to 13.6 l/min.
- ★ Choice of wetted materials .
- ★ Pressures to 25,000 psi(1723 bar).
- ★ All Hydraulic fluids, water(plain or DI), solvents, mild chemicals, liquefied gases.



Performance and Specification

Pump Model Code	Max.Out Press.	Dis. /Cycle	Max.Flow	Inlet Port	Outlet Port
AHP03-1S-5	625psi	13.6ml	8.30l/min	1"NPT	1/2"NPT
AHP03-1S-7	900psi	9.8ml	6.0l/min	3/4"NPT	1/2"NPT
AHP03-1S-12	1500psi	5.9ml	3.83l/min	3/4"NPT	1/2"NPT
AHP03-1S-21	2600psi	3.3ml	2.13l/min	3/8"NPT	1/4"NPT
AHP03-1S-36	4500psi	2.0ml	1.28l/min	3/8"NPT	1/4"NPT
AHP03-1S-71	8800psi	1.0ml	0.64l/min	3/8"NPT	1/4"NPT
AHP03-1S-110	13500psi	0.6ml	0.42l/min	3/8"NPT	1/4"NPT
AHP03-1S-188	15000psi	0.4ml	0.29l/min	3/8"NPT	1/4"HF
AHP03-1S-220	25000psi	0.34ml	0.22l/min	3/8"NPT	1/4"HF

HF means female high pressure connection.

Dimensions

Size A	3.82in.(97mm)
Size B	10in.(254mm)
Size C	1.65in.(42mm)
Size D	4.13in.(105mm)
Size E	4.72in.(120mm)
Size H	5.71in.(145mm)
Size H1	6.89in.(175mm)

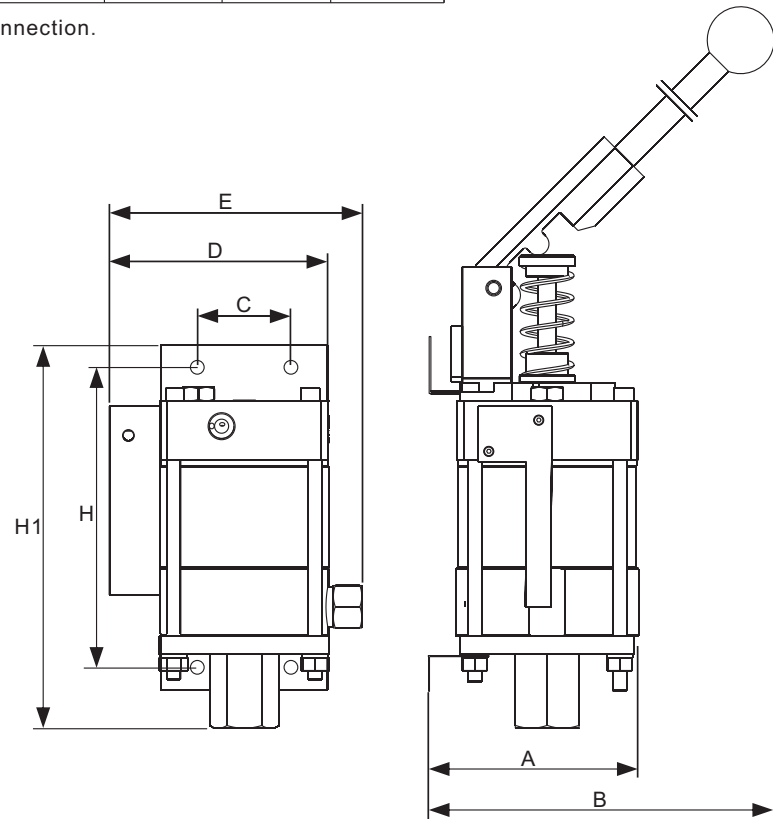

EXPLAIN

- All model code listed are standard.
 For pumps with handle add "-H" after the model codes.
 For Pumps with relief valve add "-R" after the model codes.
 For pumps with Viton seals add "-V" after the model codes.
 For pumps with Pressure switch valve add "-P" after the model codes.
 For cold area service add "-C" after the model codes.
- Other sizes, materials and types are available upon request. For special requirements, please contact us.

Performance Curves

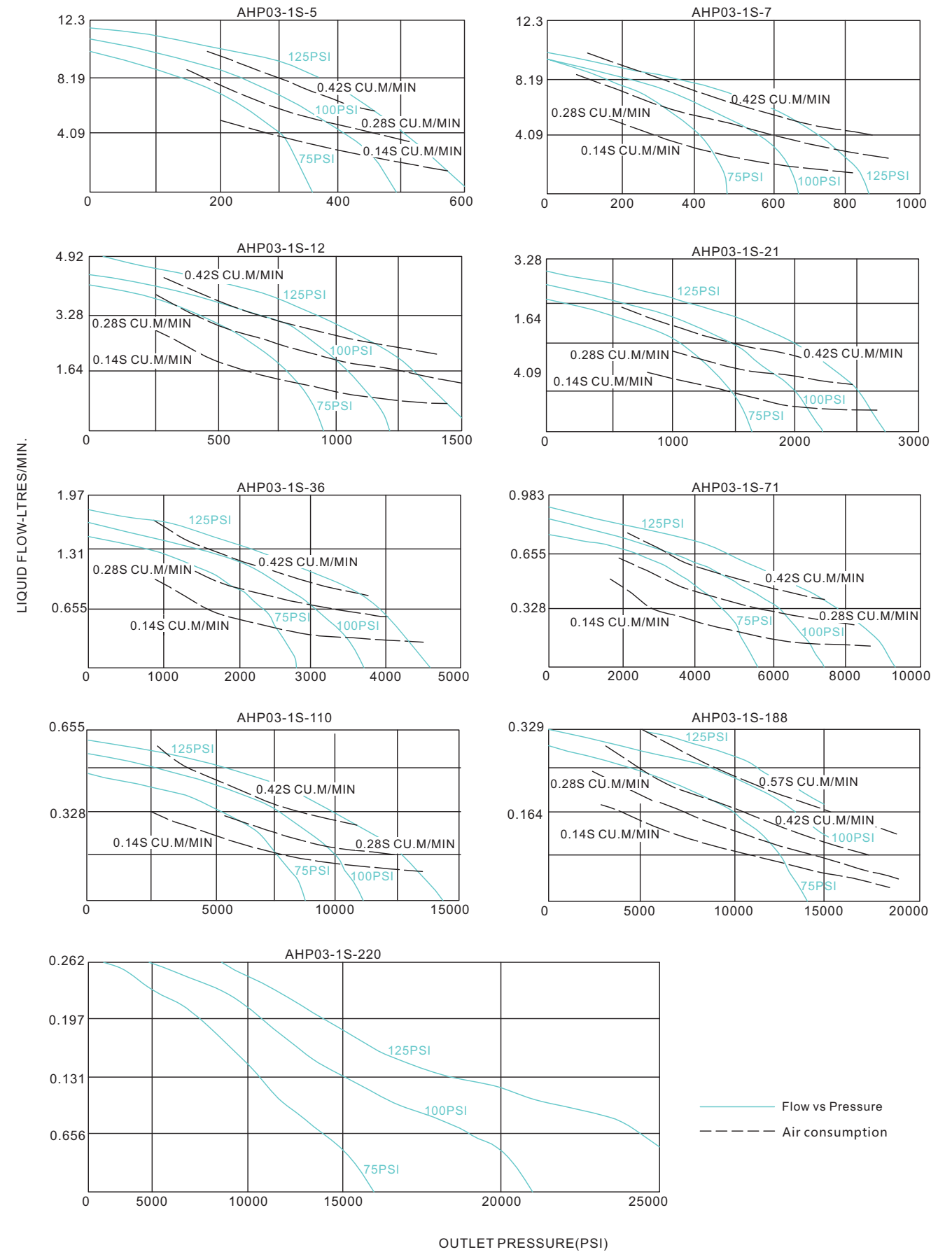



AHP06 Series

Single Drive Single Acting Features

- ★ Choice of 10 ratios.
- ★ Flows to 66.4 l/min.
- ★ Choice of wetted materials.
- ★ Output pressures to 60,000 psi (4137 bar).
- ★ Drive pressure 3 to 150 psi (0.2 to 10.3 bar).
solvents, mild chemicals, liquefied gases.

Performance and Specification

Pump Model Code	Max.Out Press.	Dis. /Cycle	Max.Flow	Inlet Port	Outlet Port
AHP06-1S-10	1600psi	66.4ml	19.9l/min	1"NPT	1/2"NPT
AHP06-1S-15	2400psi	44.3ml	13.3l/min	1"NPT	1/2"NPT
AHP06-1S-25	4000psi	26.6ml	8l/min	1/2"NPT	1/2"NPT
AHP06-1S-35	5700psi	19.0ml	5.7l/min	1/2"NPT	1/2"NPT
AHP06-1S-60	10000psi	11.0ml	3.3l/min	1/2"NPT	1/2"NPT
AHP06-1S-100	15000psi	6.7ml	2l/min	1/2"NPT	1/2"NPT
AHP06-1S-150	22500psi	4.5ml	1.3l/min	1/2"NPT	1/4"HF
AHP06-1S-225	33750psi	3.0ml	0.7l/min	1/2"NPT	1/4"HF
AHP06-1S-300	45000psi	2.3ml	0.5l/min	1/2"NPT	1/4"HF
AHP06-1S-450	60000psi	1.5ml	0.3l/min	1/2"NPT	1/4"HF

HF means female high pressure connection.

Dimensions

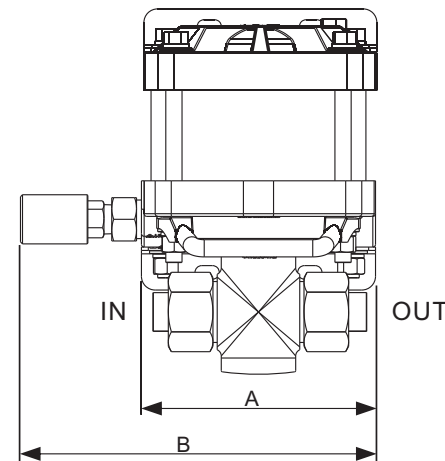
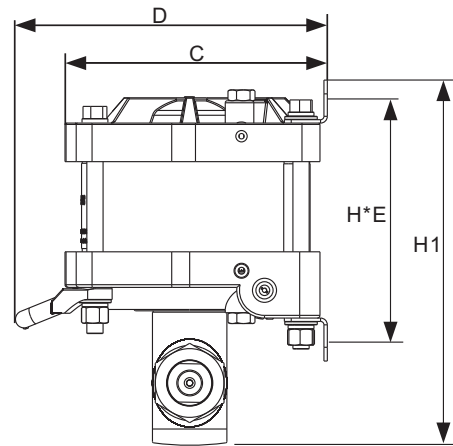

Size A	6.81in.(173mm)	Size H	7.15in.(181.5mm)
Size B	10.3in.(262mm)	Size H1	10.6in.(269.8mm)
Size C	7.64in.(194mm)	Size D	9.06in.(230mm)
Size E	3in.(76.2mm)		

EXPLAIN

- All model code listed are standard.
For angle pumps add "A" after the model codes.
For Quick repair pumps add "-Q" after the model codes.
For pumps with relief valve add "-R" after the model codes.
For pumps with Viton seals add "-V" after the model codes.
For pumps with Pressure switch valve add "-P" after the model codes.
For cold area service add "-C" after the model codes.
- Other sizes, materials and types are available upon request. For special requirements, please contact us.



Performance Curves

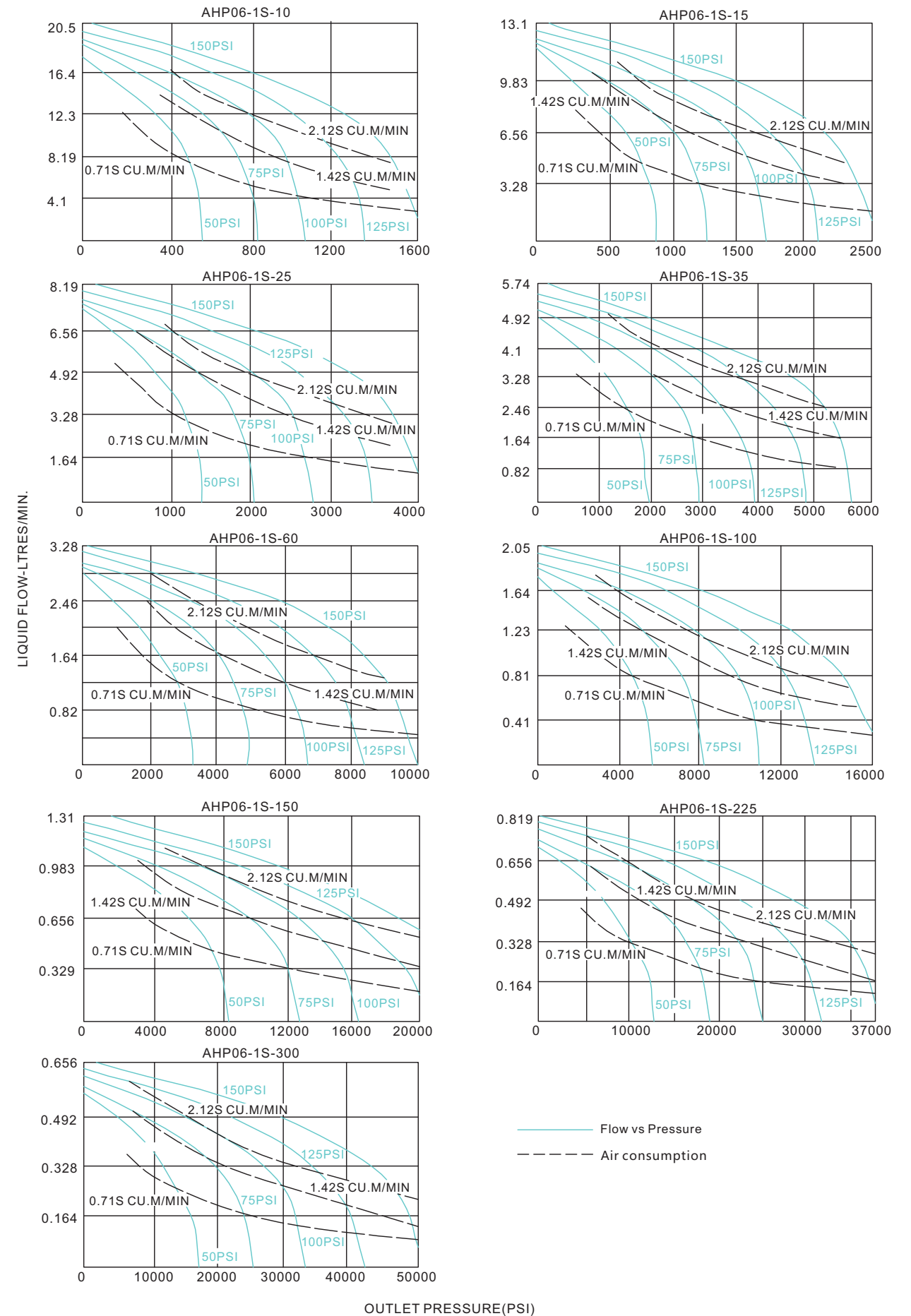



AHP06 Series

Double Drive Single Acting

Features

- ★ Choice of 9 ratios.
- ★ Flows to 19.9 l/min.
- ★ Choice of wetted materials.
- ★ Output pressures to 75,000 psi (5171 bar).
- ★ Drive pressure 3 to 150 psi (0.2 to 10.3 bar).

Performance and Specification

Pump Model Code	Max. Out Press.	Dis. /Cycle	Max. Flow	Inlet Port	Outlet Port
AHP06-2S-20	3200psi	66.4ml	19.9l/min	1"NPT	1/2"NPT
AHP06-2S-30	4800psi	44.3ml	13.3l/min	1"NPT	1/2"NPT
AHP06-2S-50	5000psi	26.6ml	8l/min	1/2"NPT	1/2"NPT
AHP06-2S-70	11000psi	19.0ml	5.7l/min	1/2"NPT	1/2"NPT
AHP06-2S-120	19000psi	11.0ml	3.3l/min	1/2"NPT	1/2"NPT
AHP06-2S-200	33000psi	6.7ml	1.5l/min	1/2"NPT	1/4"HF
AHP06-2S-300	50000psi	4.5ml	1l/min	1/2"NPT	1/4"HF
AHP06-2S-450	70000psi	3.0ml	0.7l/min	1/2"NPT	1/4"SF
AHP06-2S-600	75000psi	2.3ml	0.5l/min	1/2"NPT	1/4"SF

HF means female high pressure connection.
SF means female super high pressure connection.

Dimensions

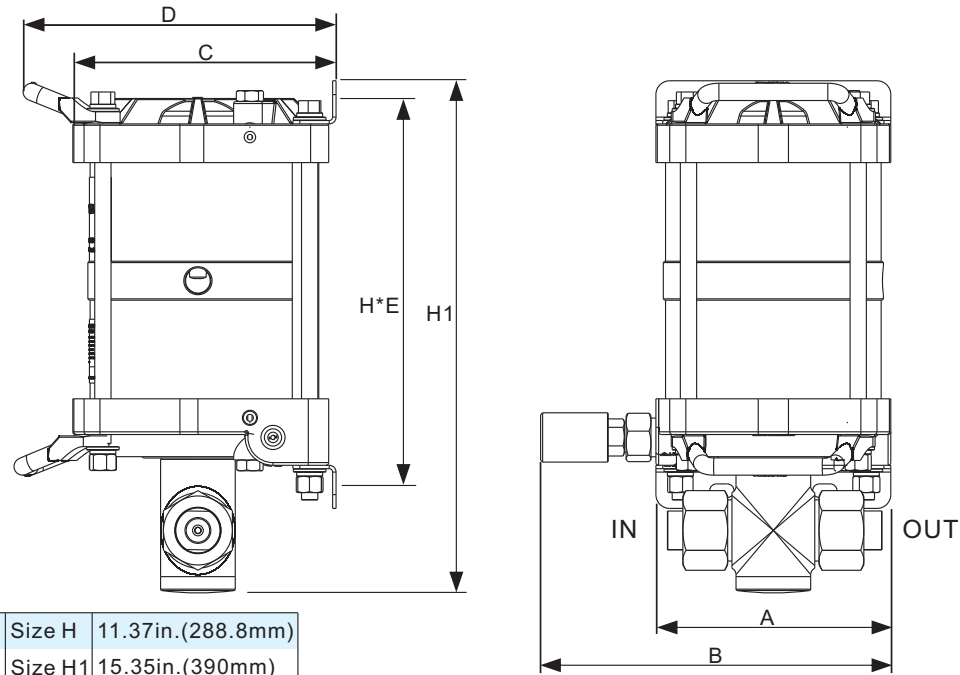

Size A	6.81in.(173mm)	Size H	11.37in.(288.8mm)
Size B	10.3in.(262mm)	Size H1	15.35in.(390mm)
Size C	7.64in.(194mm)	Size D	9.06in.(230mm)
Size E	3in.(76.2mm)		

EXPLAIN

- All model code listed are standard.
For angle pumps add "A" after the model codes.
For Quick repair pumps add "-Q" after the model codes.
For pumps with relief valve add "-R" after the model codes.
For pumps with Viton seals add "-V" after the model codes.
For pumps with Pressure switch valve add "-P" after the model codes.
For cold area service add "-C" after the model codes.

2. Other sizes, materials and types are available upon request. For special requirements, please contact us.



Performance Curves

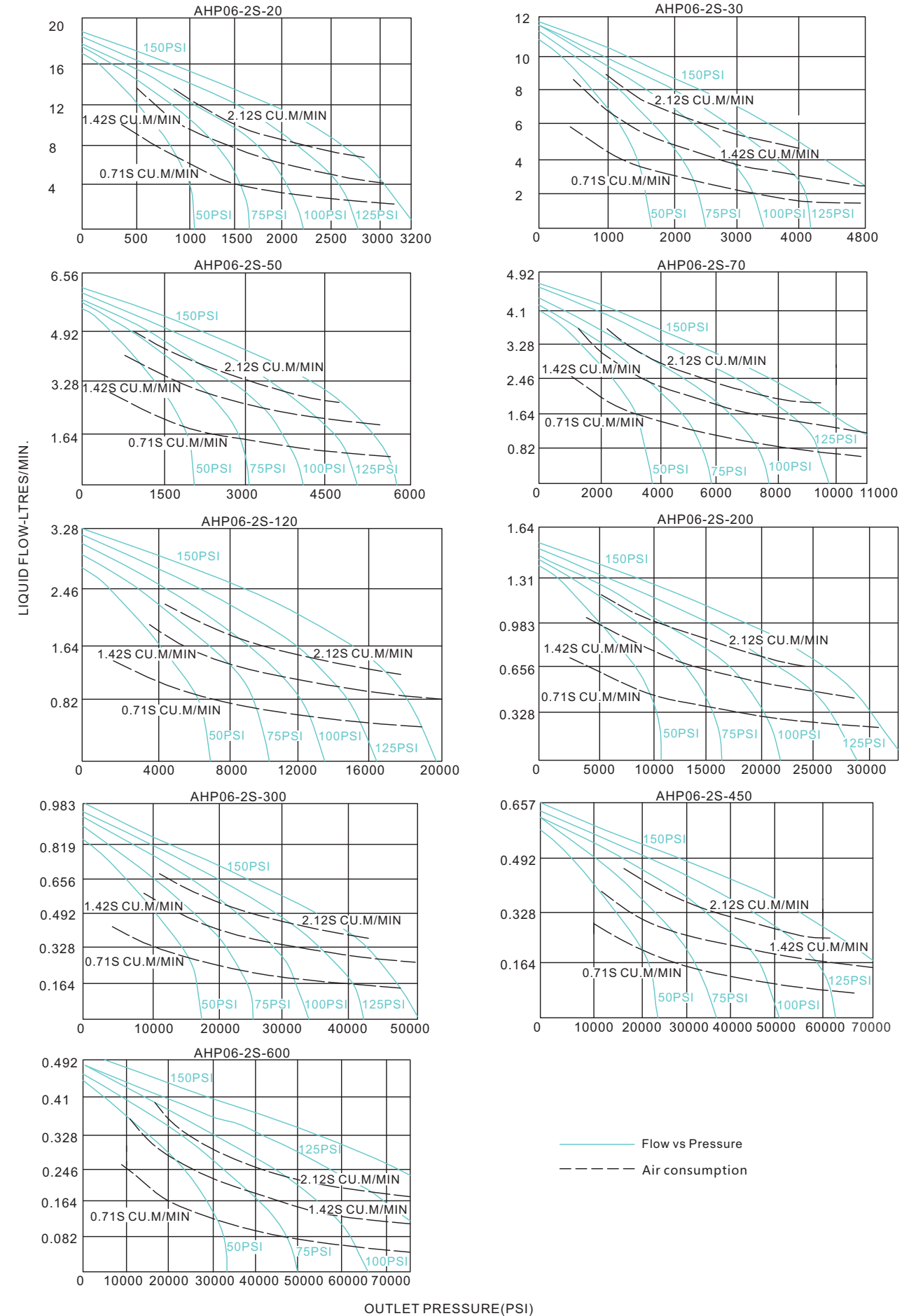



AHP06 Series

Triple Drive Single Acting Features

- ★ Choice of 3 ratios.
- ★ Flows to 0.41 l/min.
- ★ Choice of wetted materials.
- ★ Output pressures to 100,000 psi (6896 bar).
- ★ Drive pressure 3 to 150 psi (0.2 to 10.3 bar).
solvents, mild chemicals, liquefied gases.

Performance and Specification

Pump Model Code	Max.Out Press.	Dis. /Cycle	Max.Flow	Inlet Port	Outlet Port
AHP06-3S-675	70000psi	3.0ml	0.41l/min	1/2"NPT	1/4"Sf
AHP06-3S-900	75000psi	2.3ml	0.33l/min	1/2"NPT	1/4"Sf
AHP06-3S-1350	100000psi	1.5ml	0.20l/min	1/2"NPT	1/4"Sf

SF means female super high pressure connection.

Dimensions

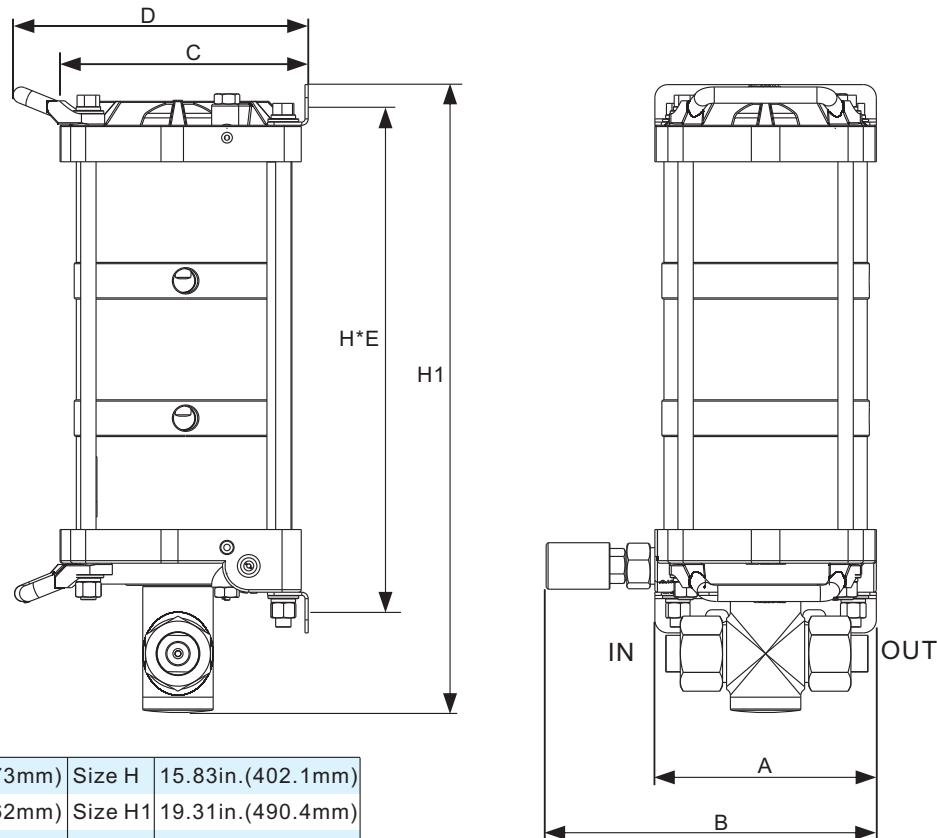

Size A	6.81in.(173mm)	Size H	15.83in.(402.1mm)
Size B	10.3in.(262mm)	Size H1	19.31in.(490.4mm)
Size C	7.64in.(194mm)	Size D	9.06in.(230mm)
Size E	3in.(76.2mm)		

EXPLAIN

- All model code listed are standard.
For angle pumps add "A" after the model codes.
For Quick repair pumps add "-Q" after the model codes.
For pumps with relief valve add "-R" after the model codes.
For pumps with Viton seals add "-V" after the model codes.
For pumps with Pressure switch valve add "-P" after the model codes.
For cold area service add "-C" after the model codes.
- Other sizes, materials and types are available upon request. For special requirements, please contact us.

Performance Curves

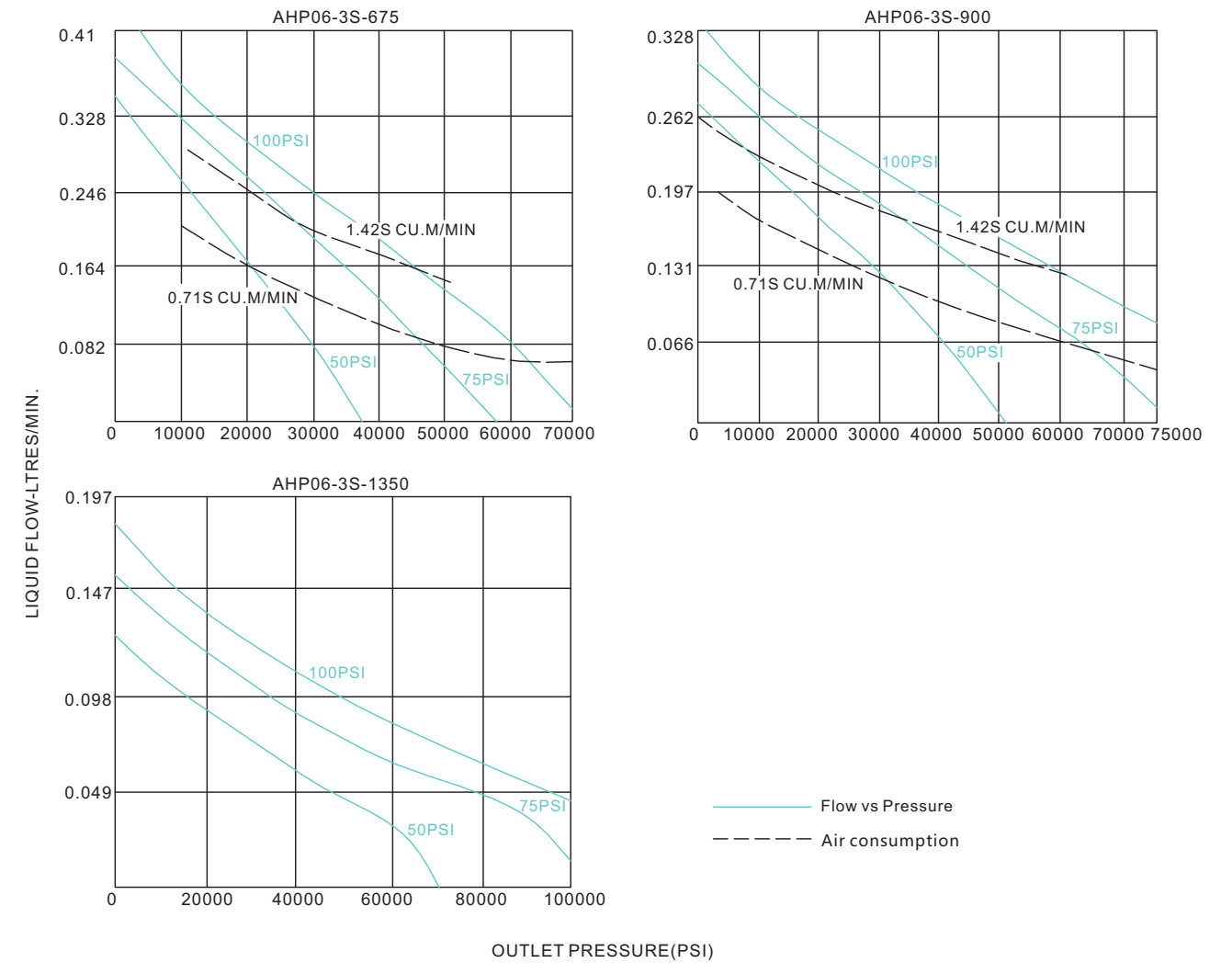



AHP06 Series

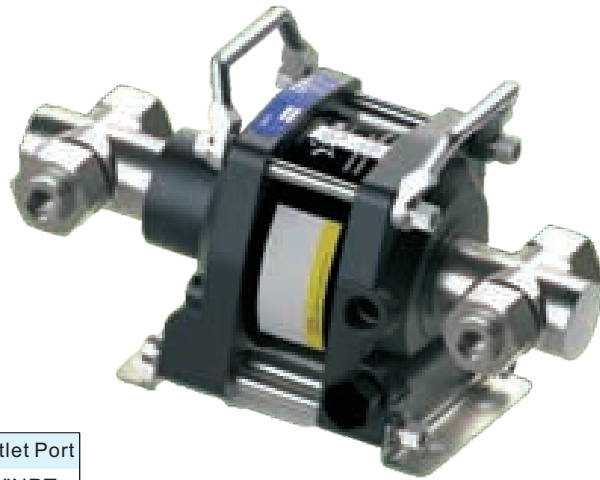

Single Drive Double Acting Features

- ★ Choice of 7 ratios.
- ★ Flows to 29.9 l/min.
- ★ Choice of wetted materials.
- ★ Output pressures to 20,000 psi (1379 bar).
- ★ Drive pressure 3 to 150 psi (0.2 to 10.3 bar).

Performance and Specification

Pump Model Code	Max. Out Press.	Dis. /Cycle	Max. Flow	Inlet Port	Outlet Port
AHP06-1D-10	1600psi	133ml	29.9l/min	1"NPT	1/2"NPT
AHP06-1D-15	2400psi	89ml	19.9l/min	1/2"NPT	1/2"NPT
AHP06-1D-25	4000psi	53.6ml	11.9l/min	1/2"NPT	1/2"NPT
AHP06-1D-35	5700psi	38ml	8.6l/min	1/2"NPT	1/2"NPT
AHP06-1D-60	9800psi	22ml	4.9l/min	1/2"NPT	1/2"NPT
AHP06-1D-100	16500psi	13.4ml	3.0l/min	1/2"NPT	3/8"MF
AHP06-1D-150	20000psi	9ml	2.0l/min	1/2"NPT	3/8"MF

MF means female medium pressure connection.

Dimensions

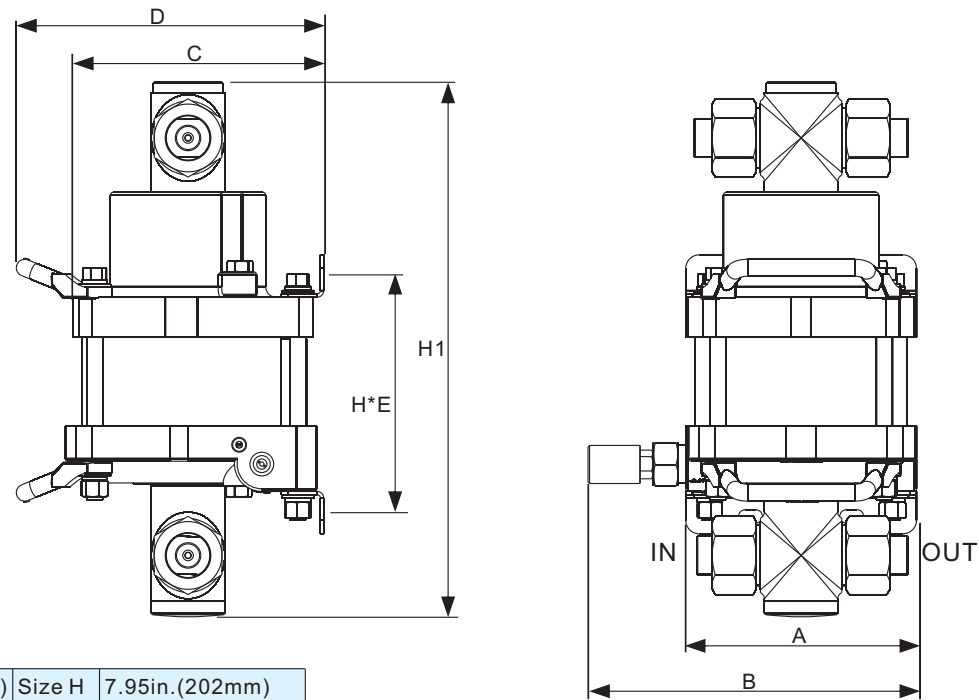

Size A	6.81in.(173mm)	Size H	7.95in.(202mm)
Size B	10.3in.(262mm)	Size H1	15.75in.(400mm)
Size C	7.64in.(194mm)	Size D	9.06in.(230mm)
Size E	3in.(76.2mm)		

EXPLAIN

- All model code listed are standard.
For angle pumps add "A" after the model codes.
For Quick repair pumps add "-Q" after the model codes.
For pumps with relief valve add "-R" after the model codes.
For pumps with Viton seals add "-V" after the model codes.
For pumps with Pressure switch valve add "-P" after the model codes.
For cold area service add "-C" after the model codes.
- Other sizes, materials and types are available upon request. For special requirements, please contact us.

Performance Curves

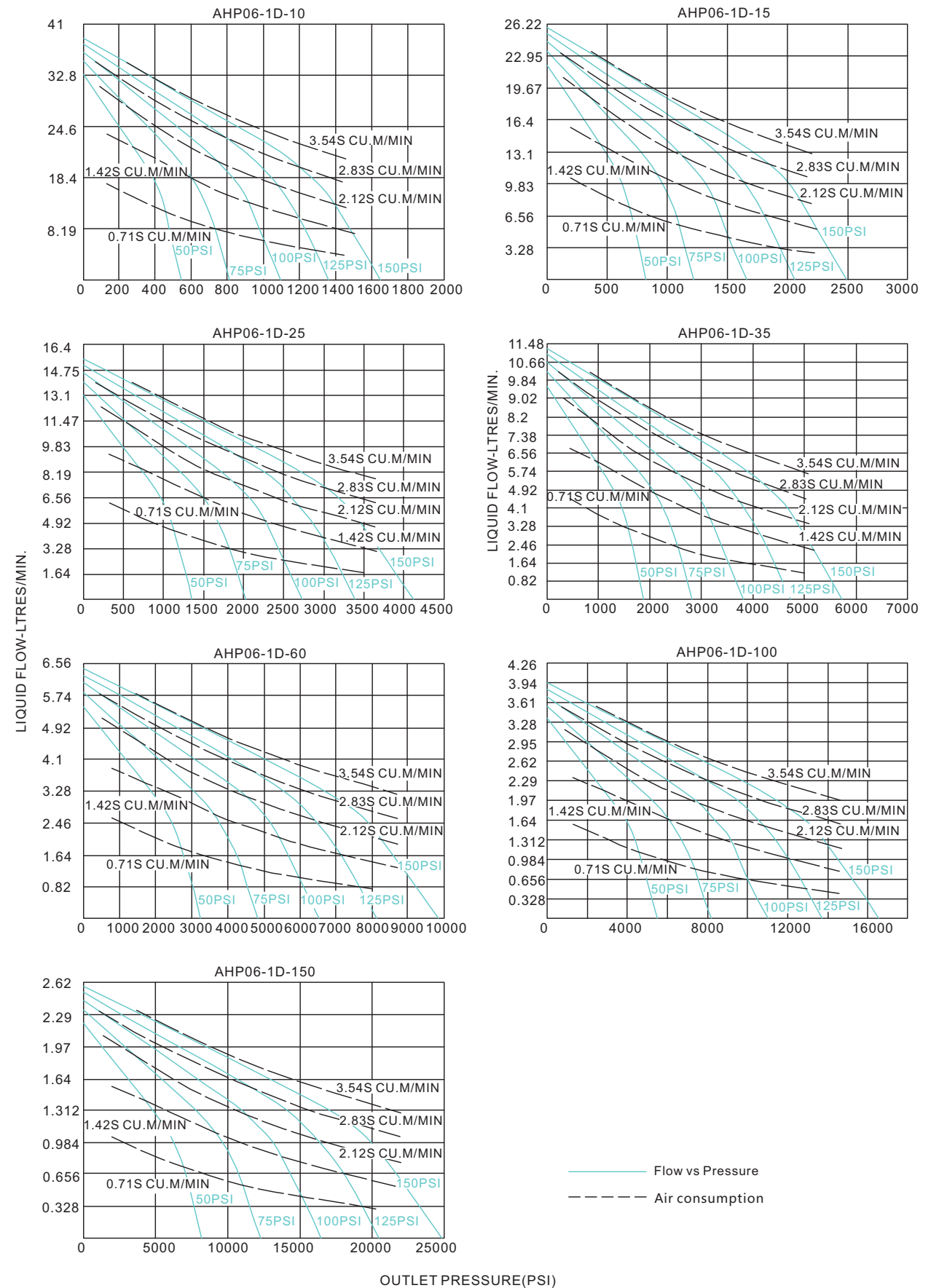



AHP06 Series

Double Drive Double Acting Features

- ★ Choice of 4 ratios.
- ★ Flows to 8.6 l/min.
- ★ Choice of wetted materials.
- ★ Output pressures to 500,000 psi (3448 bar).
- ★ Drive pressure 3 to 150 psi (0.2 to 10.3 bar).

Performance and Specification

Pump Model Code	Max. Out Press.	Dis. /Cycle	Max. Flow	Inlet Port	Outlet Port
AHP06-2D-70	11000psi	38ml	8.6l/min	1/2"NPT	1/2"NPT
AHP06-2D-120	19000psi	22ml	4.9l/min	1/2"NPT	1/2"NPT
AHP06-2D-200	33000psi	13.4ml	3.0l/min	1/2"NPT	1/4"HF
AHP06-2D-300	50000psi	9ml	2.0l/min	1/2"NPT	1/4"HF

HF means female high pressure connection.

Dimensions

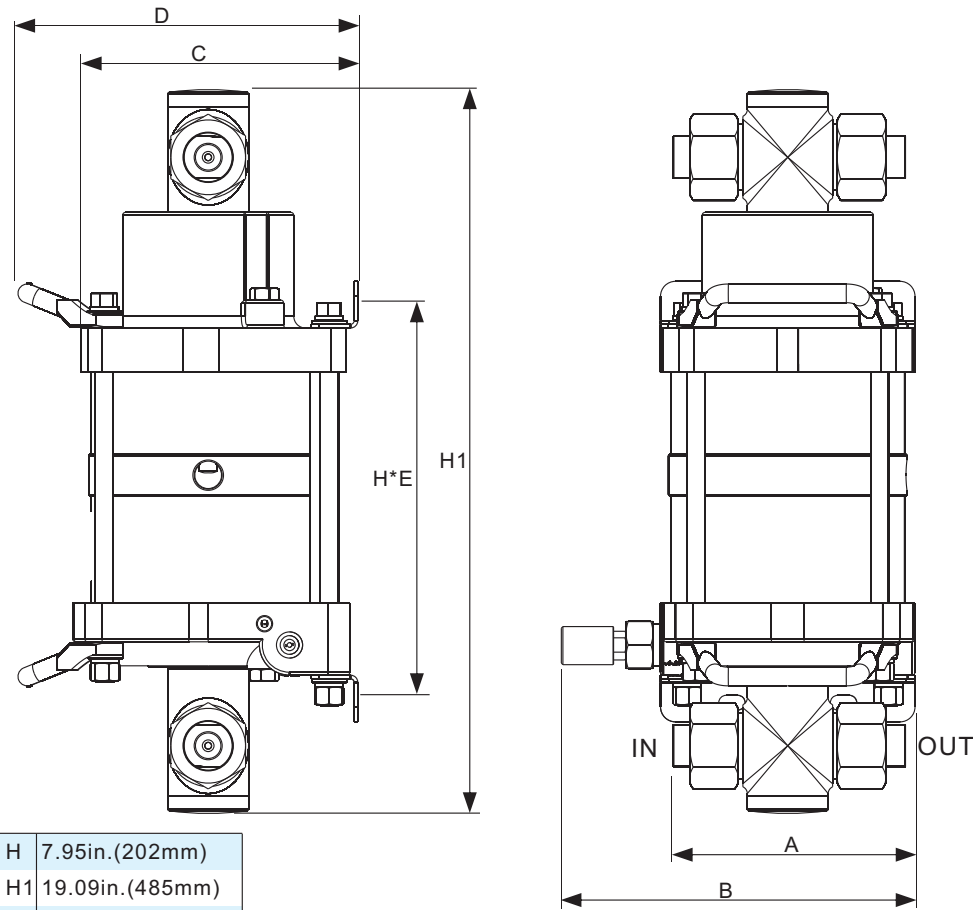

Size A	6.81in.(173mm)	Size H	7.95in.(202mm)
Size B	10.3in.(262mm)	Size H1	19.09in.(485mm)
Size C	7.64in.(194mm)	Size D	9.06in.(230mm)
Size E	3in.(76.2mm)		

EXPLAIN

- All model code listed are standard.
 For angle pumps add "A" after the model codes.
 For pumps with relief valve add "-R" after the model codes.
 For pumps with Viton seals add "-V" after the model codes.
 For pumps with Pressure switch valve add "-P" after the model codes.
 For cold area service add "-C" after the model codes.
- Other sizes, materials and types are available upon request. For special requirements, please contact us.

Performance Curves

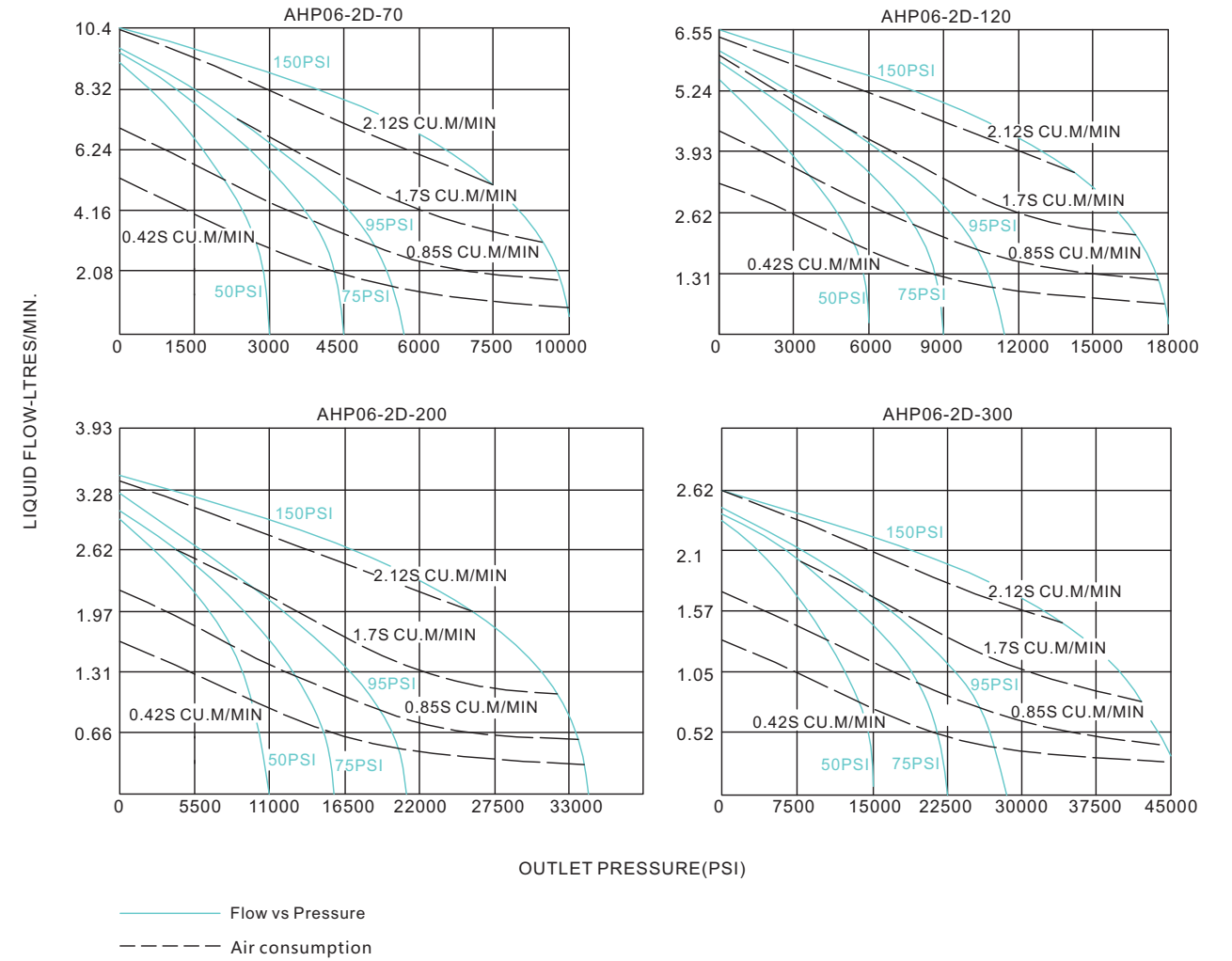



AHP06 Series

Long Stroke Single Drive Double Acting Features

- ★ Choice of 4 ratios.
- ★ Flows to 82.1 l/min.
- ★ Choice of wetted materials .
- ★ Output pressures to 100,00 psi (690 bar).
- ★ Drive pressure 3 to 125 psi (0.2 to 8.6 bar).
- ★ All hydraulic fluids,water (plain or DI),solvents.



Performance and Specification

Pump Model Code	Max.Out Press.	Dis. /Cycle	Max.Flow	Inlet Port	Outlet Port
AHP06-1D-12L	1850psi	260ml	82.1l/min	1-1/4"NPT	3/4"NPT
AHP06-1D-35L	4375psi	98ml	31l/min	1-1/4"NPT	1/2"NPT
AHP06-1D-60L	7500psi	57ml	18.1l/min	1-1/4"NPT	1/2"NPT
AHP06-1D-100L	10000psi	34ml	10.8l/min	1-1/4"NPT	1/2"NPT

Dimensions

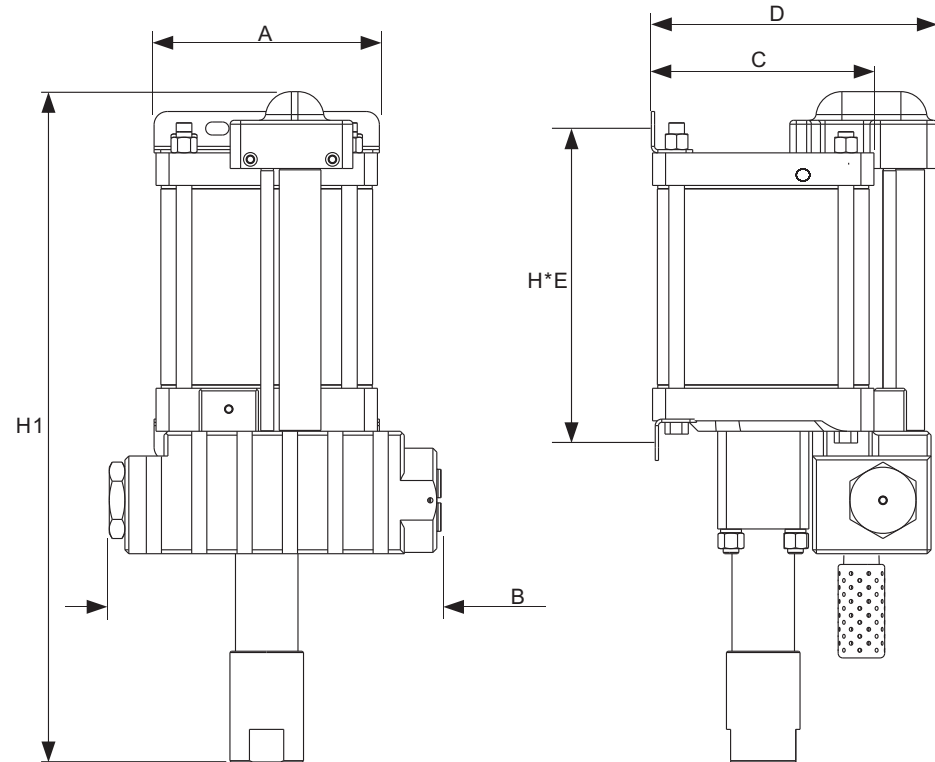

Size A	6.81in.(173mm)	Size H	9.57in.(243mm)
Size B	10in.(254mm)	Size H1	19.69in.(500mm)
Size C	6.73in.(171mm)	Size D	8.66in.(220mm)
Size E	3in.(76.2mm)		

EXPLAIN

- All model code listed are standard.
For pumps with relief valve add "-R" after the model codes.
For pumps with Viton seals add "-V" after the model codes.
For pumps with Pressure switch valve add "-P" after the model codes.
For cold area service add "-C" after the model codes.
- Other sizes,materials and types are available upon request. For special requirements, please contact us.

Performance Curves

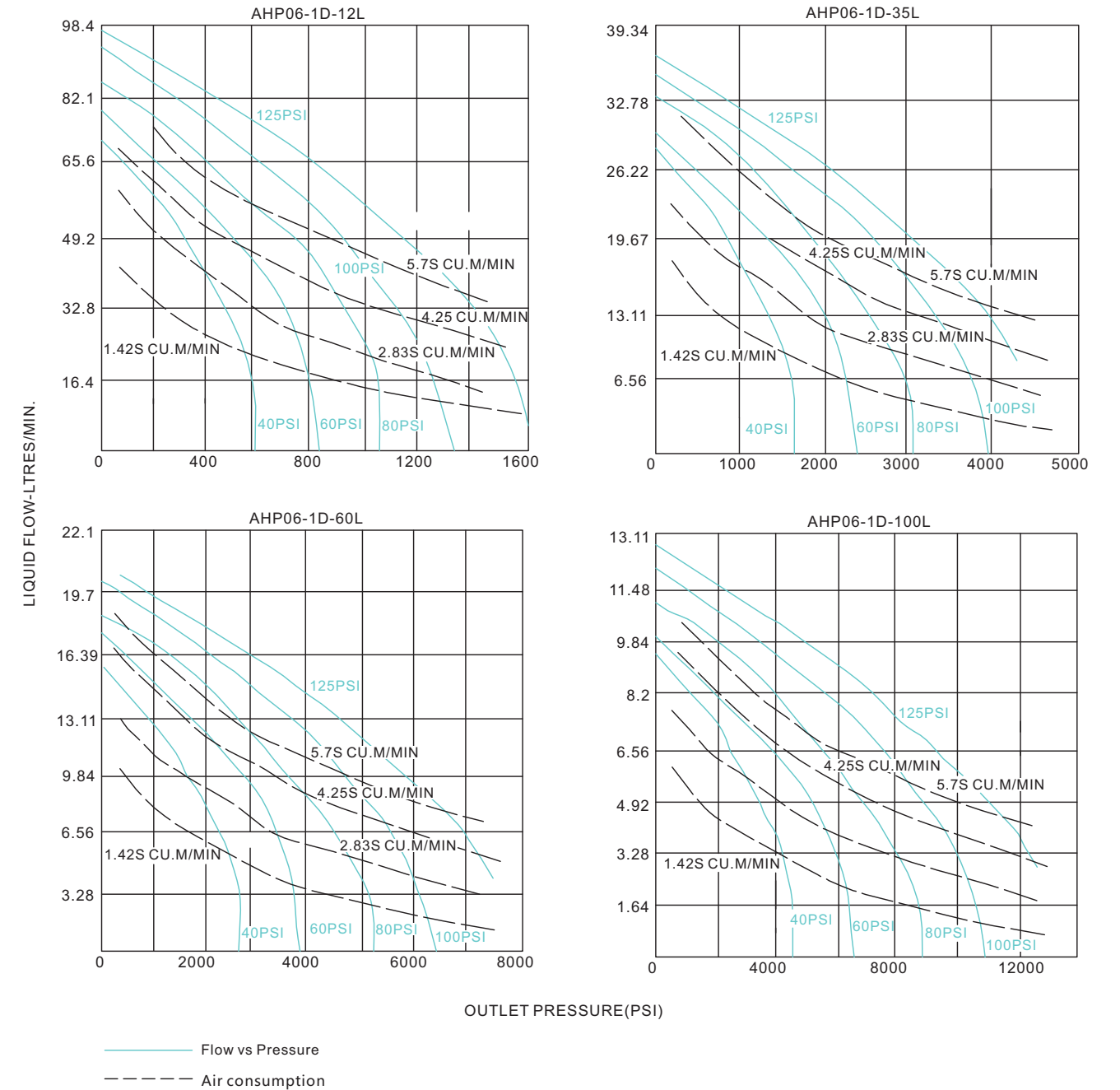



AHP10 Series

Single Drive Double Acting Features

- ★ Choice of 4 ratios.
- ★ Flows to 42 l/min.
- ★ Choice of wetted materials.
- ★ Can be quickly repaired.
- ★ Output pressures to 225,00 psi (1551 bar).
- ★ Drive pressure 3 to 125 psi (0.2 to 8.6 bar).
- ★ All hydraulic fluids, water (plain or DI), solvents liquefied gases.



Performance and Specification

Pump Model Code	Max. Out Press.	Dis. /Cycle	Max. Flow	Inlet Port	Outlet Port
AHP10-1D-30	3750psi	323ml	42l/min	1"NPT	3/4"NPT
AHP10-1D-60	7500psi	160.8ml	20.9l/min	1"NPT	1/2"NPT
AHP10-1D-120	15000psi	78.8ml	10.2l/min	1"NPT	9/16"MF
AHP10-1D-180	22500psi	48.6ml	6.3l/min	1"NPT	9/16"HF

MF means female medium pressure connection.
HF means female high pressure connection.

Dimensions

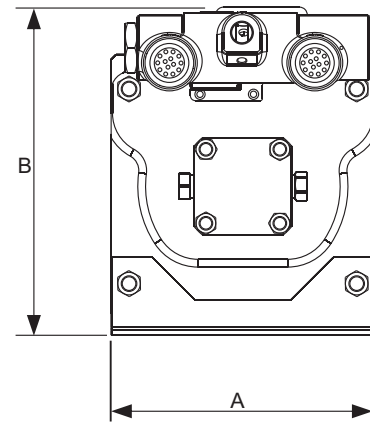
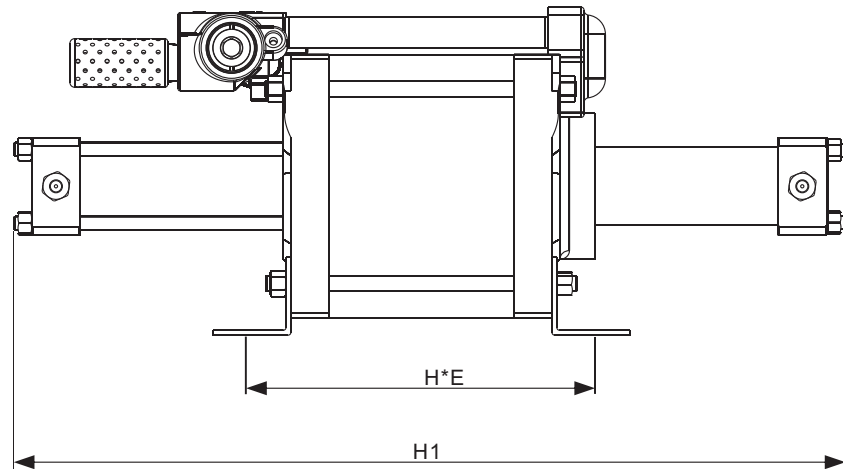

Size A	10.63in.(270mm)	Size H	23.62in.(600mm)
Size B	13.39in.(340mm)	Size H1	19.69in.(500mm)
Size E	7.87in.(200mm)		

EXPLAIN

- All model code listed are standard.
For pumps with relief valve add "-R" after the model codes.
For pumps with Viton seals add "-V" after the model codes.
For pumps with Pressure switch valve add "-P" after the model codes.
For cold area service add "-C" after the model codes.
- Other sizes, materials and types are available upon request. For special requirements, please contact us.

Performance Curves

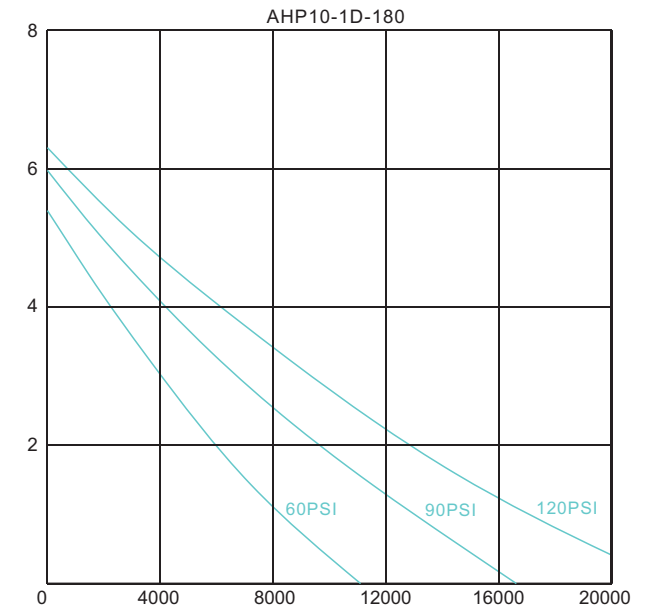
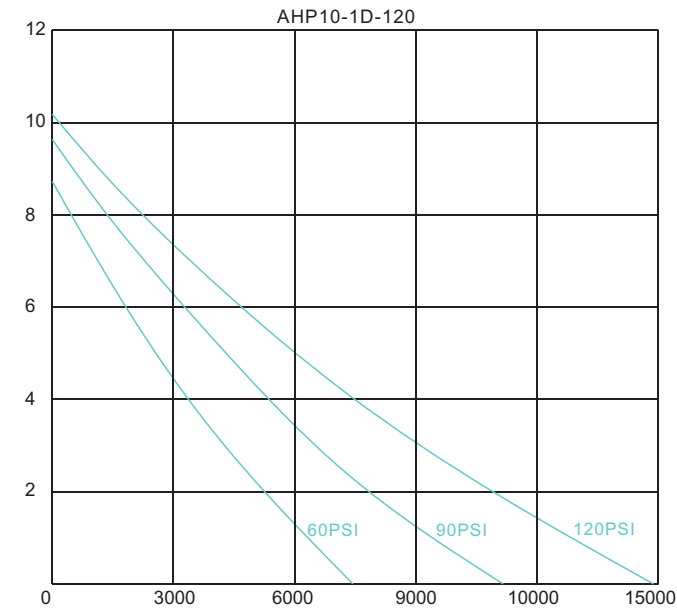
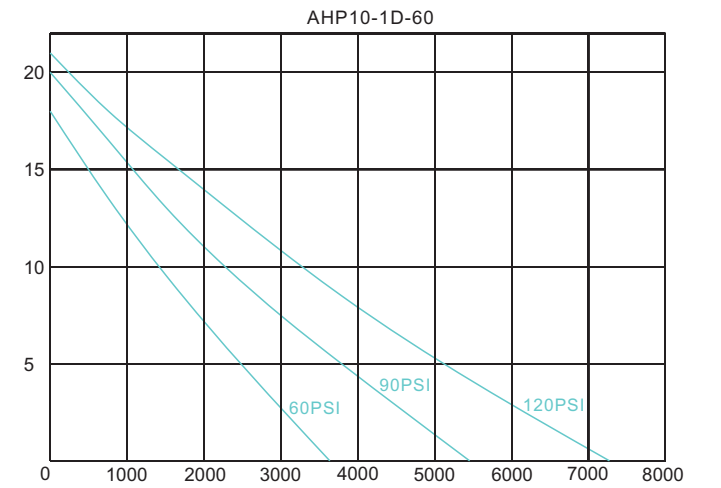
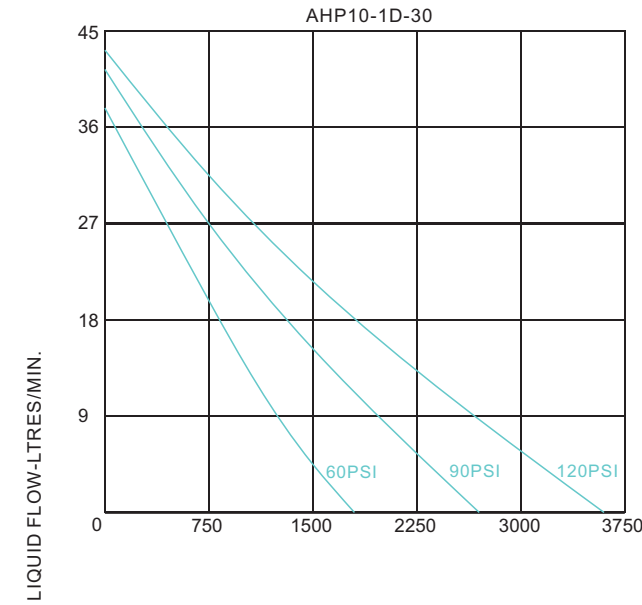

OUTLET PRESSURE(PSI)



AHP10 Series



Double Drive Double Acting Features

- ★ Choice of 4 ratios.
- ★ Flows to 25.8 l/min.
- ★ Choice of wetted materials.
- ★ Can be quickly repaired.
- ★ Output pressures to 450,00 psi (3103 bar).
- ★ Drive pressure 3 to 125 psi (0.2 to 8.9 bar).
- ★ All hydraulic fluids, water (plain or DI), solvents liquefied gases.

Performance and Specification

Pump Model Code	Max. Out Press.	Dis. /Cycle	Max. Flow	Inlet Port	Outlet Port
AHP10-2D-60	7500psi	323ml	25.8l/min	1"NPT	1/2"NPT
AHP10-2D-120	15000psi	160.8ml	12.8l/min	1"NPT	9/16"MF
AHP10-2D-240	30000psi	78.8ml	6.3l/min	1"NPT	9/16"HF
AHP10-2D-360	45000psi	48.6ml	3.9l/min	1"NPT	9/16"HF

MF means female medium pressure connection.
HF means female high pressure connection.

Dimensions

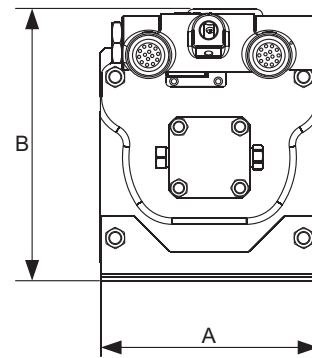
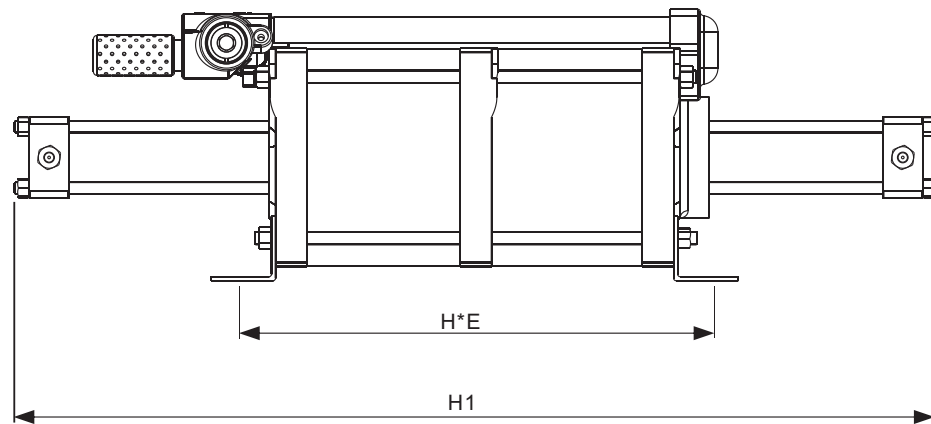

Size A	10.63in.(270mm)	Size H	49.21in.(1250mm)
Size B	13.39in.(340mm)	Size H1	26.77in.(680mm)
Size E	7.87in.(200mm)		

EXPLAIN

- All model code listed are standard.
For pumps with relief valve add "-R" after the model codes.
For pumps with Viton seals add "-V" after the model codes.
For pumps with Pressure switch valve add "-P" after the model codes.
For cold area service add "-C" after the model codes.
- Other sizes, materials and types are available upon request.
For special requirements, please contact us.

Performance Curves

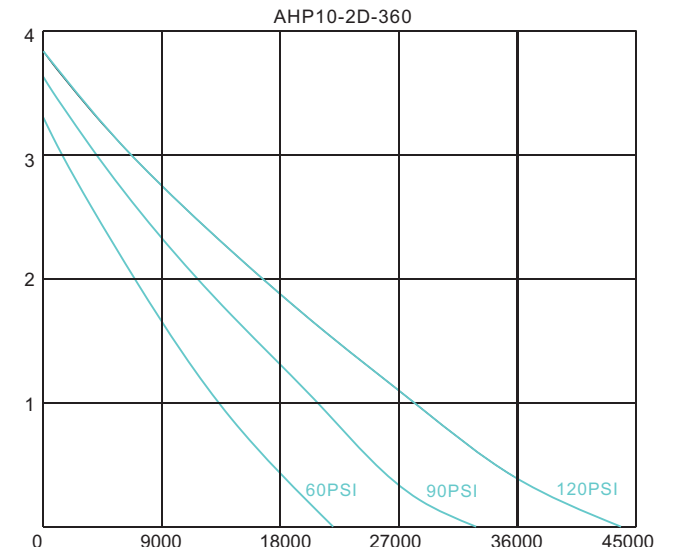
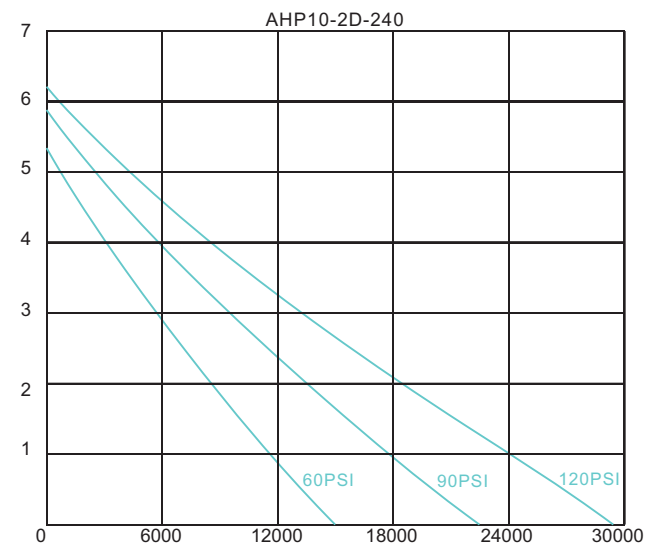
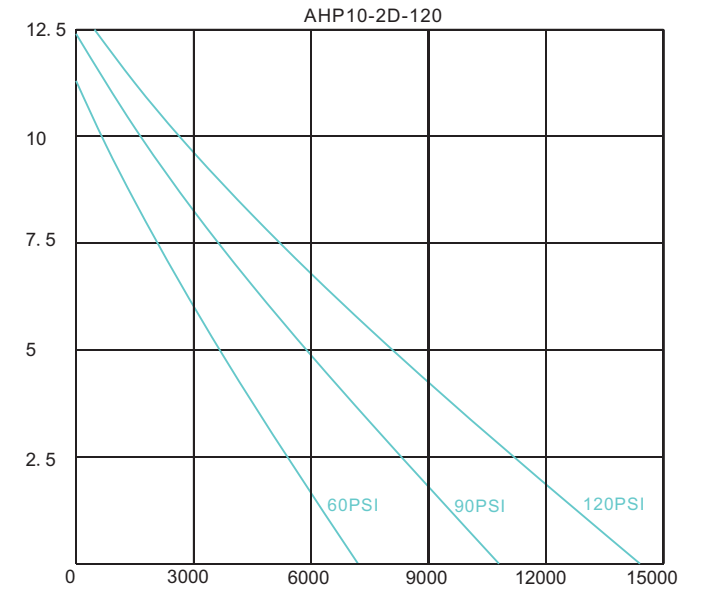
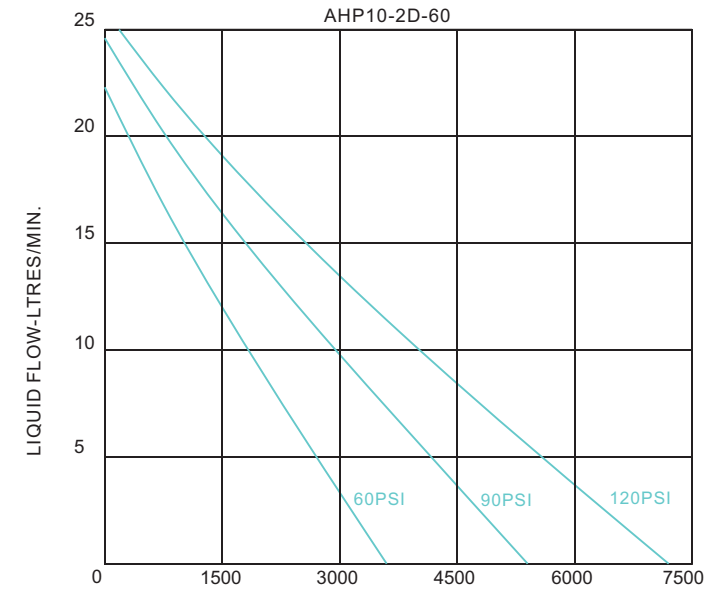

OUTLET PRESSURE(PSI)