

# XING LING REFRIGERATION

Twenty Years, Such As Quality, Worthy Of Trust.



## COMPANY PROFILE

Guangzhou XingLing Kitchen Refrigeration Equipment Co.,Ltd is one of emerging technology company ,Its core is manufacturing technology and refrigeration equipment. We offer not only high-quality refrigeration solutions to customers,but also the most energy-efficient economic environment-friendly refrigeration products (display cabinets,supermarket display cabinets,drug cooler display cabinets,kitchen freezers ,cake showcase and so on) to the world. We make our customers to be more competitive with our professional experience.

## PROFESSIONAL DESIGN

Our equipments are designed with streamlined lines appearance which is nice,elegant and practical. And user-friendly design function makes our products to achieve the perfect fusion from inside to outside.We strictly according to ISO9001 international quality management system, and fused the advanced technology and top technology to provide the accurate recommendations and the most innovative design solutions for customers.

## QUALITY ASSURANCE

For xingling,quality is satisfying customers.We continuously test and complete our products and process flow. We use leading technology facilities ,advanced equipment and conscientious attitude to implement the producing and products quality management system.And achieving a comprehensive excellence xingling.

### DELICACY

Exquisite quality, taste fresh life.

### FRESH

See the fresh,xing ling will Interpret the price for you.

### POTENCY

Awaken potential of refrigeration, dance out of the new Xing ling.

### IMAGINE

Through the brush of imagination, The glory of the dye xing ling and pentium.

## INNOVATION

Xingling products are renowned in the industrial with its outstanding innovation and practical application. We continuously optimize products quality and our service to give our clients greatest satisfaction. We are closely aligned with external collaborations, we also have excellent development teams and the support of educational institutions. Through technology investments and R & D, Our technical planning is to ensuring sustainable products and benefit both customers and end consumers.



## COMPANY STRENGTH

XingLing refrigeration is one of emerging technology company which is manufacturing technology and refrigeration equipment as the core. We offer not only high-quality refrigeration solutions to customers,but also the most energy-efficient economic environment-friendly refrigeration products (display cabinets,supermarket display cabinets,drug cooler display cabinets,kitchen freezers ,cake showcase and so on)to the world.We make our customers to be more competitive with your professional experience.

XingLing fuses technology and refrigeration technology.In a dynamic world, we are perseverance and pursuing perfection to create a competitive advantage refrigeration solutions for customers.In the future,Our aim is to develop greater capacity and efficiency products in the context of ensuring economic and product quality.



## ENTERPRISE CATALOG//

XingLing has a variety of advanced processing and production equipment, a variety of professional staff at all levels. Jun Jian today for the development of the enterprise to meet customer needs, in order to "continuous innovation, customer satisfaction, rapid improvement, full participation" as the basic quality; with exquisite production technology, strict service spirit and strict testing procedures, make high quality products are pouring out, effectively to meet the different needs of customers.

# DESIGN

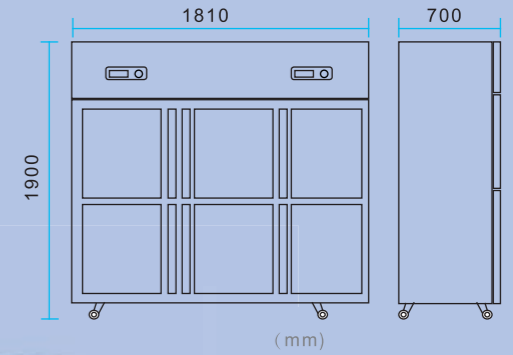
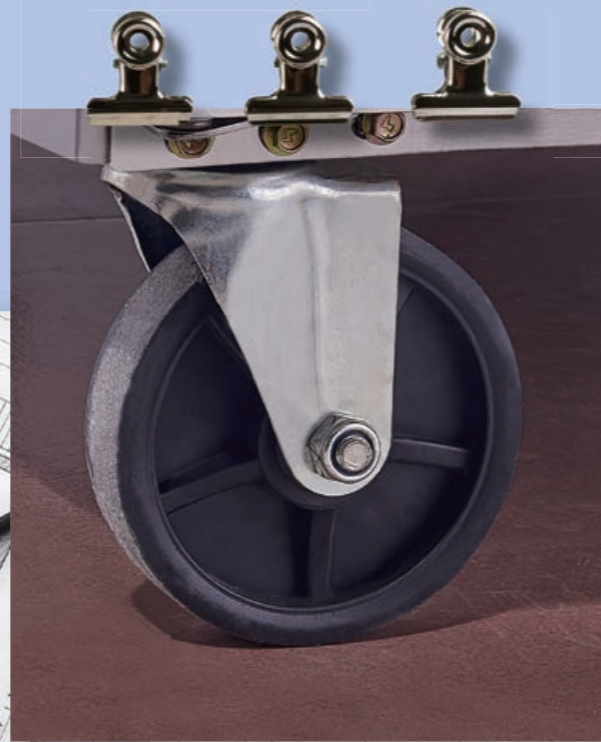
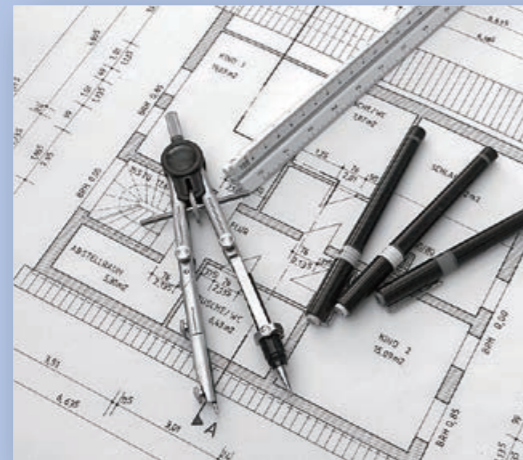

# XING LING

In pieces stereo enjoy fresh experience Luxury and beauty light box and cabinet lighting design, Microcomputer temperature control, Simple and fluent line, Pieces of atmospheric SanKaiMen show appearance In pieces and transparent glass window design; Pieces of ice cool and fresh feeling, In pieces the air-filled solid circulation, refrigeration and no dead Angle, In pieces to create perfect stable cold storage space; Your life acme, pieces make you relaxed.



Guangzhou XingLing company gathered a group of young people who love design, composed of design team, with the "heart", "Jane" in the "shape" design concept, with passion and inspiration to give the brand higher value. Our company's design team is determined to be the most closely designed value manager of the brand, and to be a professional design company that provides excellent design for customers and makes design profitable for the brand. Sharing the value of design achievements with more customers and sharing the joys of design is what we mean.



RAPID COOLING  
ENERGY SAVING

XING LING



#### INDUSTRY REPUTATION BEYOND 86% PEERS

More than ten, the quality of continuous pursuit, from the details of the departure, the completion of self optimization, the quality of persistence, is "Xing Ling" commitment to customers.

#### XINGLING COMPANY AND OTHER MARKET SEGMENTS

XingLing, all the way forward, as you do, in order to greater prospects continue to transcend themselves.

赞

NICE!!

괜찮다



RAPID COOLING  
ENERGY SAVING

## CONTENTS

### SHOWCASE SERIES

PAGE 07~30

### AIR CURTAIN CABINET SERIES

PAGE 31~38

### CAKE CABINET SERIES

PAGE 39~48

### KITCHEN CABINET SERIES

PAGE 49~74

MORE PRODUCTS FOR YOU TO FIND

[WWW.GZXINGLING.COM](http://WWW.GZXINGLING.COM)

GZXINGLING.COM

## SHOWCASE SERIES RAPID COOLING ENERGY SAVING

The display cabinet is a display platform provided with protective function for the display of goods. The color can be chosen according to the shop decoration. The display cabinet has the advantages of firm structure, easy disassembly and assembly, and convenient transportation. It is widely used in exhibition halls, exhibitions, department stores, advertisements and so on, and has been widely used in various industries.

In order to maximize the attraction and attract customers, the display cabinet must give full play to the designers' creative ability and imagination, and create an unconventional aesthetic image. At the same time, we must pay attention to the authenticity of aesthetic creation, that is, the information conveyed must be accurate, not exaggerated, bluffing, and this is also a key issue in the production of modern commercial display cabinets. Otherwise, not only will lose credibility, against the occupation morals, but also cause consumers psychological distrust and antipathy. Eight of the five advertising tenets of the American business community are about authenticity, that is, facts, no temptation, prices, exaggeration, honesty, etc. At the same time, emphasizing the authenticity of commercial counter production does not mean denying the richness of the technique of expression. On the contrary, in order to arouse people's emotion and arouse their desire to purchase, we must pay attention to the uniqueness, richness and novelty of the technique of expression.

### RAPID REFRIGERATION

- 1.Three-dimensional fresh,enjoy the experience
- 2.Effective utilization of land area.
- 3.High light box and lighting design.
- 4.Dual display effect,enhance the brand image.
- 5.Simple fluid lines.
- 6.Wide transparent glass window design.
- 7.Exudes a stylish atmosphere,permeated inside and outside the cabinet.
- 8.Enjoy your cool life every day.

### DELICACY

Exquisite quality, taste fresh life.

### FRESH

See the fresh,xing ling will Interpret the price for you.

### POTENCY

Awaken potential of refrigeration, dance out of the new Xing ling.

### IMAGINE

Through the brush of imagination, The glory of the dye xing ling and pentium.

## SHOWCASE SERIES

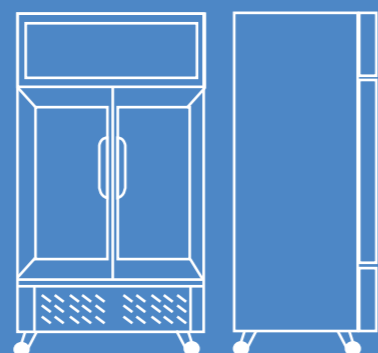

## REFRIGERATION EQUIPMENT

EXPERIENCE LEADING TECHONLOGY,FOCUS ON LIFE

Our equipments are designed with streamlined lines appearance which is nice,elegant and practical.And user-friendly design function makes our products to achieve the perfect fusion from inside to outside.We strictly according to ISO9001 international quality management system, and fused the advanced technology and top technology to provide the accurate recommendations and the most innovative design solutions for customers.

## ENTERPRISE MISSION

EXPERIENCE LEADING TECHONLOGY,FOCUS ON LIFE

Taste fashion and enjoy comfort! Xing Ling founded five years, with its product and market the constant pursuit of love and potential enterprise charm, gather a large number of excellent management and technical personnel, has a strong professional design team, the international environmental standards in line with the raw and auxiliary materials, and change according to market needs and constantly updated, and establish as a modern management model and standardized production process.

For xingling,quality is satisfying customers.We continuously test and complete our products and process flow. We use leading technology facilities ,advanced equipment and conscientious attitude to implement the producing and products quality management system.And achieving a comprehensive excellence xingling.

# SHOWCASE SERIES

In pieces stereo enjoy fresh experience Luxury and beauty light box and cabinet lighting design, Microcomputer temperature control, Simple and fluent line, Pieces of atmospheric SanKaiMen show appearance In pieces and transparent glass window design, Pieces of ice cool and fresh feeling, In pieces the air-filled solid circulation, refrigeration and no dead Angle, In pieces to create perfect stable cold storage space; Your life acme, pieces make you relaxed.



XING LING



# 01

## SHOWCASE SERIES

EXPERIENCE LEADING TECHONLOGY, FOCUS ON LIFE

1. Lighting in cabinet body.
2. Visual beauty in all directions.
3. Built in high quality plastic dip shelf.
4. Precision control of science and technology.
5. Door with lock.
6. Fast and strong cooling.
7. Double layers hollow glass door.
8. Static cooling system.
9. Chinese brand compressor.

### Single door display cabinet



#### ◀ LG-58B

Model	<b>LG-58B</b>
Dimension(mm)	535x430x885
Voltage Source	220V/50Hz
Input Power	130W
Temperature Rang	0~10°C
Cooling Way	Static
Refrigerant	R134a
Escription	Single Door

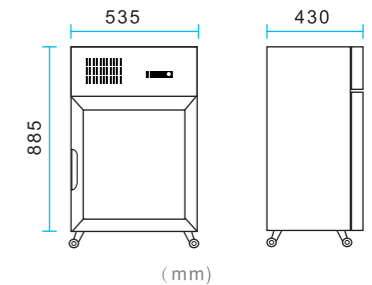

### Beverage display cabinet



#### ◀ LG-188B/LG-218B/LG-280B

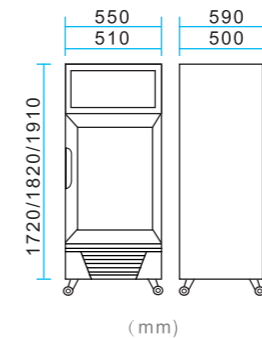

#### ◀ LG-380B/LG380B2

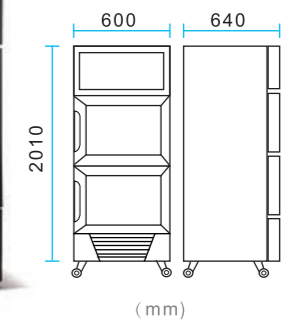

Model	<b>LG-188B</b>	<b>LG-218B</b>	<b>LG-280B</b>	<b>LG-380B</b>	<b>LG-380B2</b>
Dimension(mm)	510x500x1720	550x500x1820	550x590x1910	600x640x2010	600x640x2010
Voltage Source	220V/50Hz	220V/50Hz	220V/50Hz	220V/50Hz	220V/50Hz
Input Power	135W	135W	175W	200W	200W
Temperature Rang	0~10°C	0~10°C	0~10°C	0~10°C	0~10°C
Cooling Way	Static	Static	Static	Static	Static
Refrigerant	R134a	R134a	R134a	R134a	Two Door
Escription	Single Door	Single Door	Single Door	Single Door	Single Door

Guangzhou XingLing Kitchen Refrigeration Equipment Co.,Ltd is one of emerging technology company ,Its core is manufacturing technology and refrigeration equipment. We offer not only high-quality refrigeration solutions to customers, but also the most energy-efficient economic environment-friendly refrigeration products (display cabinets, supermarket display cabinets, drug cooler display cabinets, kitchen freezers ,cake showcase and so on) to the world. We make our customers to be more competitive with our professional experience. Our equipments are designed with streamlined lines appearance which is nice, elegant and practical. And user-friendly design function makes our products to achieve the perfect fusion from inside to outside. We strictly according to ISO9001 international quality management system, and fused the advanced technology and top technology to provide the accurate recommendations and the most innovative design solutions for customers.

## PROFESSIONAL DESIGN

- 1.Fast and strong cooling.
- 2.Double layers hollow glass door.
- 3.Visual beauty in all directions.
- 4.Automatic temperature control.
- 5.Door with lock.
- 6.Built in high quality plastic dip shelf.
- 7.LED lighting.
- 8.Large capacity storage.
- 9.Static cooling system.
- 10.Chinese brand compressor.

# 01

## SHOWCASE SERIES

EXPERIENCE LEADING TECHNOLOGY, FOCUS ON LIFE

- 1.Three-dimensional fresh, enjoy the experience.
- 2.Effective utilization of land area.
- 3.High light box and lighting design.
- 4.Dual display effect, enhance the brand image.
- 5.Simple fluid lines.
- 6.Wide transparent glass window design.
- 7.Exudes a stylish atmosphere, permeated inside and outside the cabinet.
- 8.Enjoy your cool life every day.

Beverage display cabinet



◀ LG-680B/LG-760B

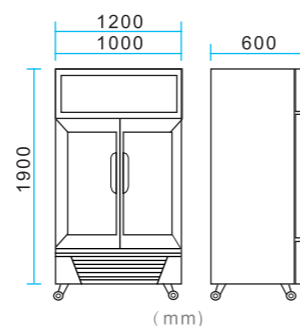

Model	LG-680B	LG-760B
Dimension(mm)	1000x600x1900	1200x600x1900
Voltage Source	220V/50Hz	220V/50Hz
Input Power	200W	240W
Temperature Rang	0~10°C	0~10°C
Cooling Way	Static	Static
Refrigerant	R134a	R134a
Escription	Two Door	Two Door

Beverage display cabinet



◀ LG-1300B

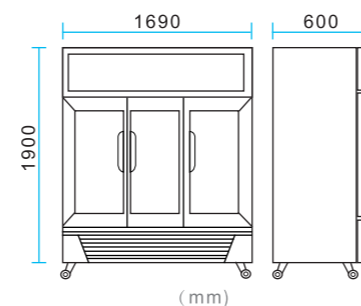

Model	LG-1300B
Dimension(mm)	1690x600x1900
Voltage Source	220V/50Hz
Input Power	490W
Temperature Rang	0~10°C
Cooling Way	Static
Refrigerant	R134a
Escription	Three Door

Cryogenic freezer



◀ LG-780F

Model	LG-780F
Dimension(mm)	1200x600x2100
Voltage Source	220V/50Hz
Input Power	580W
Temperature Rang	-18°C
Cooling Way	Air Cooling
Refrigerant	R134a
Escription	Two door

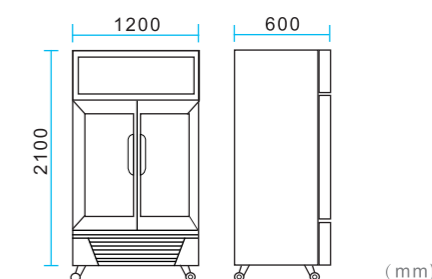

## XING LING

### Quality Assurance, Industry Reputation Beyond 86% Peers

For xingling, quality is satisfying customers. We continuously test and complete our products and process flow. We use leading technology facilities, advanced equipment and conscientious attitude to implement the producing and products quality management system. And achieving a comprehensive excellence xingling. More than ten, the quality of continuous pursuit, from the details of the departure, the completion of self optimization, the quality of persistence, is "Xing Ling" commitment to customers.

# SHOWCASE SERIES

In pieces stereo enjoy fresh experience Luxury and beauty light box and cabinet lighting design, Microcomputer temperature control, Simple and fluent line, Pieces of atmospheric SanKaiMen show appearance In pieces and transparent glass window design; Pieces of ice cool and fresh feeling, In pieces the air-filled solid circulation, refrigeration and no dead Angle, In pieces to create perfect stable cold storage space; Your life acme, pieces make you relaxed.



XING LING

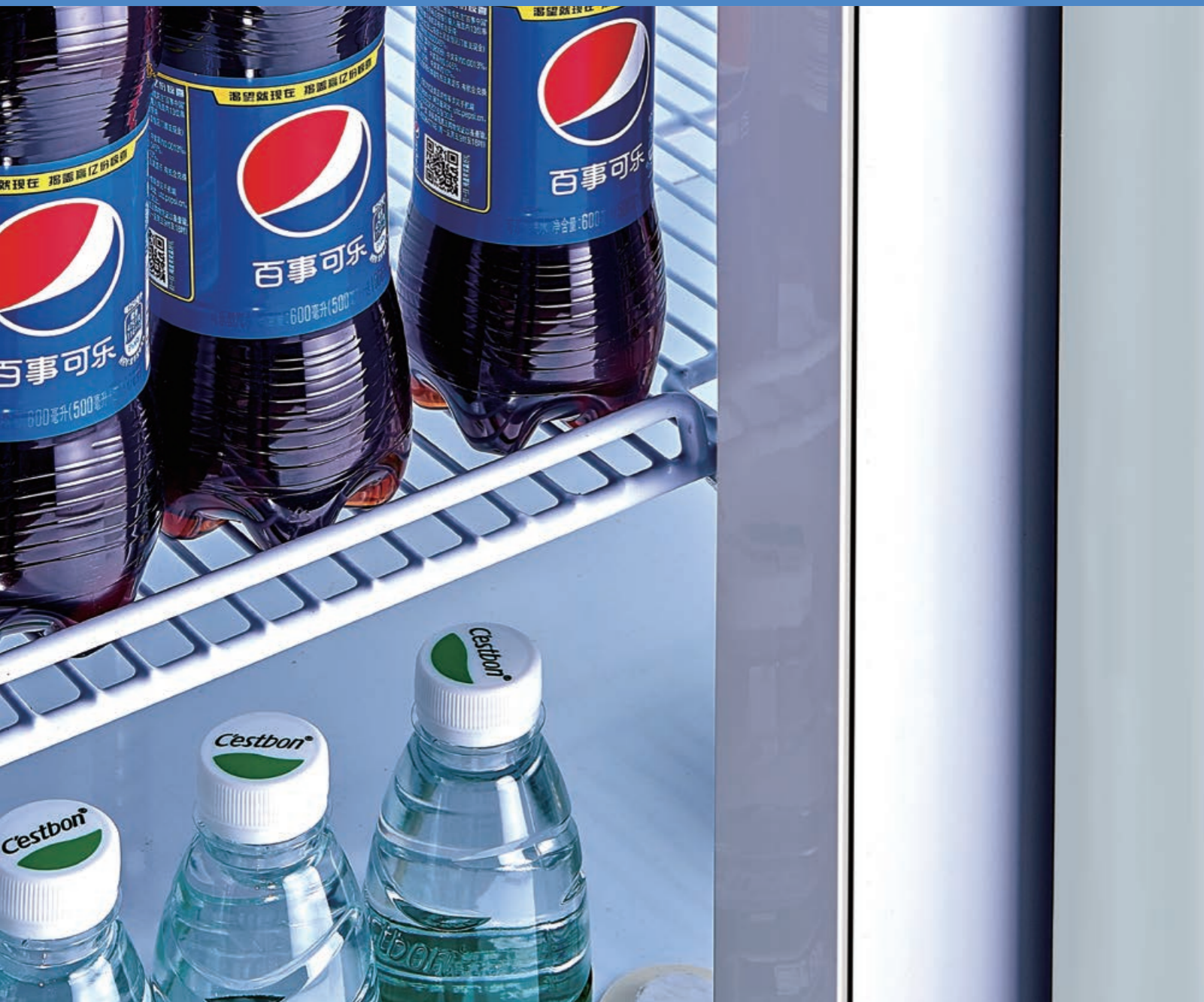

# 01

## SHOWCASE SERIES

EXPERIENCE LEADING TECHNOLOGY, FOCUS ON LIFE

- 1.Imported brand compressor.
- 2.Highlight colour steel design.
- 3.Three-dimensional advertising light box.
- 4.Double layers hollow glass door.
- 5.Micro computer automatic temperature control.
- 6.LED lighting.
- 7.Visual beauty in all dire ctions.
- 8.Built in high quality plastic dip shelf.

Beverage display cabinet



### INDUSTRY REPUTATION BEYOND 86% PEERS

More than ten, the quality of continuous pursuit, from the details of the departure, the completion of self optimization, the quality of persistence, is "Xing Ling" commitment to customers.

#### ◀ HG-430A

Model	<b>HG-430A</b>
Dimension(mm)	620x645x2050
Voltage Source	220V/50Hz
Input Power	150W
Temperature Rang	0~10°C
Cooling Way	Static
Refrigerant	R134a
Escription	Single Door

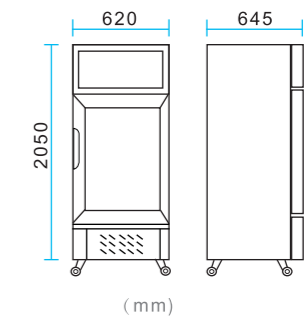

Beverage display cabinet



#### ◀ HG-700A / HG-800A

Model	<b>HG-700A</b>	<b>HG-800A</b>
Dimension(mm)	1060x645x2050	1260x645x2050
Voltage Source	220V/50Hz	220V/50Hz
Input Power	280W	300W
Temperature Rang	0~10°C	0~10°C
Cooling Way	Static	Static
Refrigerant	R134a	R134a
Escription	Two Door	Two Door

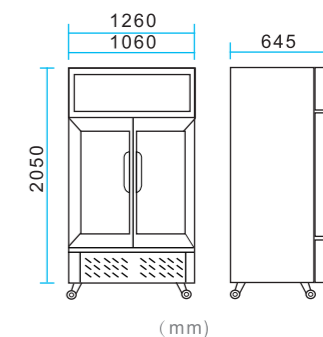

Guangzhou XingLing Kitchen Refrigeration Equipment Co.,Ltd is one of emerging technology company ,Its core is manufacturing technology and refrigeration equipment. We offer not only high-quality refrigeration solutions to customers, but also the most energy-efficient economic environment-friendly refrigeration products (display cabinets, supermarket display cabinets, drug cooler display cabinets, kitchen freezers, cake showcase and so on) to the world. We make our customers to be more competitive with our professional experience. Our equipments are designed with streamlined lines appearance which is nice, elegant and practical. And user-friendly design function makes our products to achieve the perfect fusion from inside to outside. We strictly according to ISO9001 international quality management system, and fused the advanced technology and top technology to provide the accurate recommendations and the most innovative design solutions for customers.



## PROFESSIONAL DESIGN

1. Fast and strong cooling.
2. Double layers hollow glass door.
3. Visual beauty in all directions.
4. Automatic temperature control.
5. Door with lock.
6. Built in high quality plastic dip shelf.
7. LED lighting.
8. Large capacity storage.
9. Static cooling system.
10. Chinese brand compressor.

# 01

## SHOWCASE SERIES

EXPERIENCE LEADING TECHNOLOGY, FOCUS ON LIFE

1. Three-dimensional fresh, enjoy the experience.
2. Effective utilization of land area.
3. High light box and lighting design.
4. Dual display effect, enhance the brand image.
5. Simple fluid lines.
6. Wide transparent glass window design.
7. Exudes a stylish atmosphere, permeated inside and outside the cabinet.
8. Enjoy your cool life every day.

Beverage display cabinet

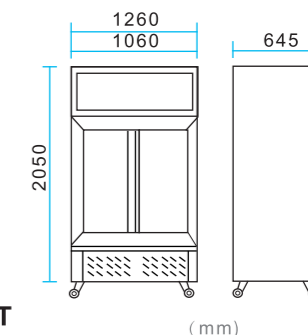

◀ HG-700AT / HG-800AT (mm)

Model	HG-700AT	HG-800AT
Dimension(mm)	1060x645x2050	1260x645x2050
Voltage Source	220V/50Hz	220V/50Hz
Input Power	650W	750W
Temperature Rang	0~10°C	0~10°C
Cooling Way	Static	Static
Refrigerant	R134a	R134a
Escription	Two Door	Two Door

Beverage display cabinet

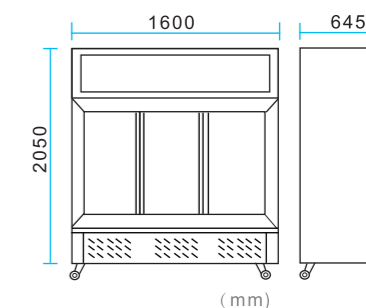

◀ HG-1100AT (mm)

Model	HG-1100AT
Dimension(mm)	1600x645x2050
Voltage Source	220V/50Hz
Input Power	480W
Temperature Rang	0~10°C
Cooling Way	Static
Refrigerant	R134a
Escription	Three Door

Beverage display cabinet



- ◎ **DELICACY**  
Exquisite quality, taste fresh life.
- ◎ **FRESH**  
See the fresh, xing ling will Interpret the price for you.
- ◎ **POTENCY**  
Awaken potential of refrigeration, dance out of the new Xing ling.
- ◎ **IMAGINE**  
Through the brush of imagination, The glory of the dye xing ling and pentium.

▲ HG-1100A

Model	HG-1100A
Dimension(mm)	1600x645x2050
Voltage Source	220V/50Hz
Input Power	480W
Temperature Rang	0~10°C
Cooling Way	Static
Refrigerant	R134a
Escription	Three Door

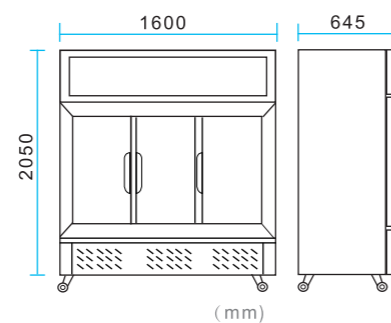





# 01

## SHOWCASE SERIES

EXPERIENCE LEADING TECHNOLOGY, FOCUS ON LIFE

- 1.Imported brand compressor.
- 2.Highlight colour steel design.
- 3.Three-dimensional advertising light box.
- 4.Double layers hollow glass door.
- 5.Micro computer automatic temperature control.
- 6.LED lighting.
- 7.Visual beauty in all directions.
- 8.Built in high quality plastic dip shelf.

### Beverage display cabinet



EXPERIENCE LEADING TECHNOLOGY, FOCUS ON LIFE

- 1.Three-dimensional fresh, enjoy the experience.
- 2.Effective utilization of land area.
- 3.High light box and lighting design.
- 4.Dual display effect, enhance the brand image.
- 5.Simple fluid lines.
- 6.Wide transparent glass window design.
- 7.Exudes a stylish atmosphere, permeated inside and outside the cabinet.
- 8.Enjoy your cool life every day.

#### ◀ LG-188B1 / LG-218B1 / LG-280B1 / LG-380B1

Model	LG-188B1	LG-218B1	LG-280B1	LG-380B1
Dimension(mm)	510x500x1720	550x500x1820	550x590x1910	600x640x2010
Voltage Source	220V/50Hz	220V/50Hz	220V/50Hz	220V/50Hz
Input Power	135W	135W	175W	200W
Temperature Rang	0~10°C	0~10°C	0~10°C	0~10°C
Cooling Way	Static	Static	Static	Static
Refrigerant	R134a	R134a	R134a	R134a
Escription	Single Door	Single Door	Single Door	Single Door

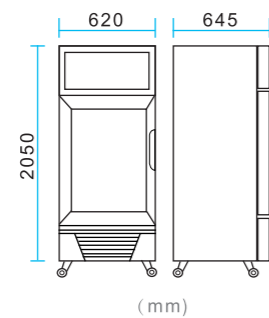

### Professional Design

Our equipments are designed with streamlined lines appearance which is nice, elegant and practical. And user-friendly design function makes our products to achieve the perfect fusion from inside to outside. We strictly according to ISO9001 international quality management system, and fused the advanced technology and top technology to provide the accurate recommendations and the most innovative design solutions for customers.

### Quality Assurance

For xingling, quality is satisfying customers. We continuously test and complete our products and process flow. We use leading technology facilities, advanced equipment and conscientious attitude to implement the producing and products quality management system. And achieving a comprehensive excellence xingling.

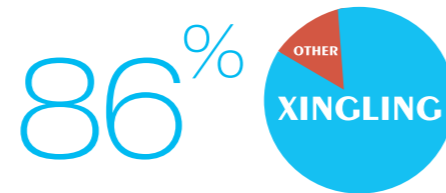

### Industry Reputation Beyond 86% Peers

More than ten, the quality of continuous pursuit, from the details of the departure, the completion of self optimization, the quality of persistence, is "Xing Ling" commitment to customers.

### Beverage display cabinet



#### ◀ LG-680T/LG-760T

Model	LG-680T	LG-760T
Dimension(mm)	1000x600x1900	1200x600x1900
Voltage Source	220V/50Hz	220V/50Hz
Input Power	200W	240W
Temperature Rang	0~10°C	0~10°C
Cooling Way	Static	Static
Refrigerant	R134a	R134a
Escription	Two Door	Two Door

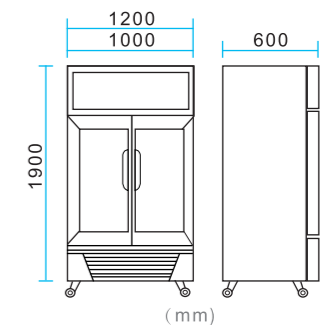

### Beverage display cabinet



#### ◀ LG-1300T

Model	LG-1300T
Dimension(mm)	1690x600x1900
Voltage Source	220V/50Hz
Input Power	480W
Temperature Rang	0~10°C
Cooling Way	Static
Refrigerant	R134a
Escription	Three Door

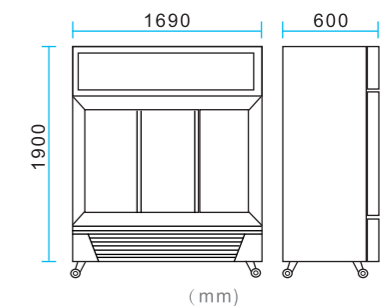



### PROFESSIONAL DESIGN

1. Fast and strong cooling.
2. Double layers hollow glass door.
3. Visual beauty in all directions.
4. Automatic temperature control.
5. Door with lock.
6. Built in high quality plastic dip shelf.
7. LED lighting.
8. Large capacity storage.
9. Static cooling system.
10. Chinese brand compressor.

# 01

## ROSE GOLD SERIES

EXPERIENCE LEADING TECHNOLOGY, FOCUS ON LIFE

1. Imported brand compressor.
2. Highlight colour steel design.
3. Three-dimensional advertising light box.
4. Double layers hollow glass door.
5. Micro computer automatic temperature control.
6. LED lighting.
7. Visual beauty in all directions.
8. Built in high quality plastic dip shelf.

Beverage display cabinet



◀ LG-680B1/LG-760B1

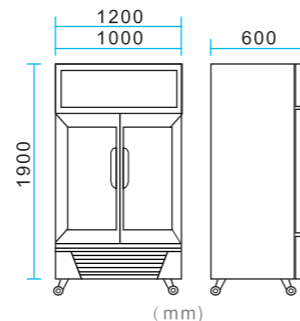

Model	LG-680B1	LG-760B1
Dimension(mm)	1000x600x1900	1200x600x1900
Voltage Source	220V/50Hz	220V/50Hz
Input Power	200W	240W
Temperature Rang	0~10°C	0~10°C
Cooling Way	Static	Static
Refrigerant	R134a	R134a
Escription	Two Door	Two Door

Beverage display cabinet



◀ LG-1300B1

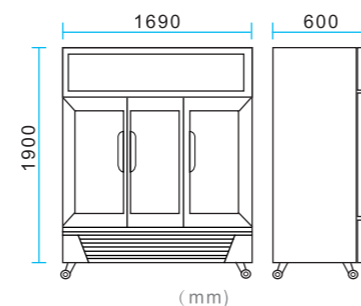

Model	LG-1300B1
Dimension(mm)	1690x600x1900
Voltage Source	220V/50Hz
Input Power	480W
Temperature Rang	0~10°C
Cooling Way	Static
Refrigerant	R134a
Escription	Three Door

Luxury straight cold



### INDUSTRY REPUTATION BEYOND 86% PEERS

More than ten, the quality of continuous pursuit, from the details of the departure, the completion of self optimization, the quality of persistence, is "Xing Ling" commitment to customers.

◀ HG-430B

Model	HG-430B
Dimension(mm)	620x645x2050
Voltage Source	220V/50Hz
Input Power	220W
Temperature Rang	0~10°C
Cooling Way	Static
Refrigerant	R134a
Escription	Single Door

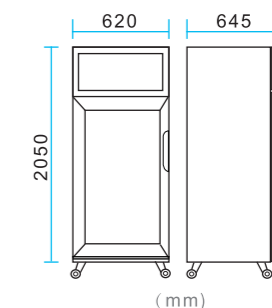

Luxury straight cold



### Professional Design

Our equipments are designed with streamlined lines appearance which is nice, elegant and practical. And user-friendly design function makes our products to achieve the perfect fusion from inside to outside. We strictly according to ISO9001 international quality management system, and fused the advanced technology and top technology to provide the accurate recommendations and the most innovative design solutions for customers.

◀ HG-430A1

Model	HG-430A1
Dimension(mm)	620x645x2050
Voltage Source	220V/50Hz
Input Power	220W
Temperature Rang	0~10°C
Cooling Way	Static
Refrigerant	R134a
Escription	Single Door

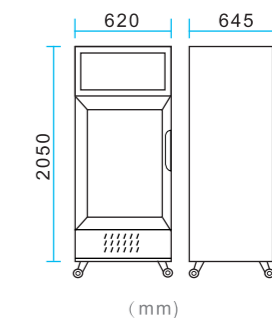



### PROFESSIONAL DESIGN

1. Fast and strong cooling.
2. Double layers hollow glass door.
3. Visual beauty in all directions.
4. Automatic temperature control.
5. Door with lock.
6. Built in high quality plastic dip shelf.
7. LED lighting.
8. Large capacity storage.
9. Static cooling system.
10. Chinese brand compressor.

# 01

## ROSE GOLD SERIES

EXPERIENCE LEADING TECHNOLOGY, FOCUS ON LIFE

1. Three-dimensional fresh, enjoy the experience.
2. Effective utilization of land area.
3. High light box and lighting design.
4. Dual display effect, enhance the brand image.
5. Simple fluid lines.
6. Wide transparent glass window design.
7. Exudes a stylish atmosphere, permeated inside and outside the cabinet.
8. Enjoy your cool life every day.

Luxury straight cold



◀ HG-700B / HG-800B

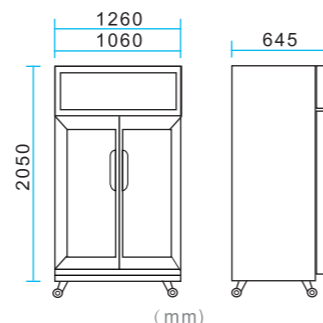

Model	HG-700B	HG-800B
Dimension(mm)	1060x645x2050	1260x645x2050
Voltage Source	220V/50Hz	220V/50Hz
Input Power	320W	380W
Temperature Rang	0~10°C	0~10°C
Cooling Way	Static	Static
Refrigerant	R134a	R134a
Escription	Two Door	Two Door

Luxury straight cold



◀ HG-700A1 / HG-800A1

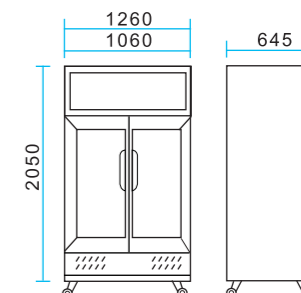

Model	HG-700A1	HG-800A1
Dimension(mm)	1060x645x2050	1260x645x2050
Voltage Source	220V/50Hz	220V/50Hz
Input Power	320W	380W
Temperature Rang	0~10°C	0~10°C
Cooling Way	Static	Static
Refrigerant	R134a	R134a
Escription	Two Door	Two Door

Luxury straight cold



### INDUSTRY REPUTATION BEYOND 86% PEERS

More than ten, the quality of continuous pursuit, from the details of the departure, the completion of self optimization, the quality of persistence, is "Xing Ling" commitment to customers.

◀ HG-1100B

Model	HG-1100B
Dimension(mm)	1600x645x2050
Voltage Source	220V/50Hz
Input Power	350W
Temperature Rang	0~10°C
Cooling Way	Static
Refrigerant	R134a
Escription	Three Door

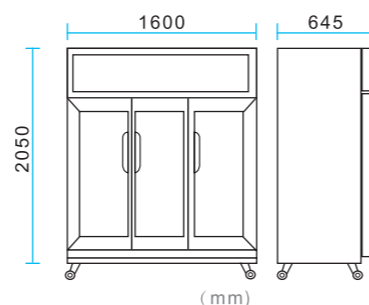

Luxury straight cold



◀ HG-1100A1

Model	HG-1100A1
Dimension(mm)	1690x620x1920
Voltage Source	220V/50Hz
Input Power	350W
Temperature Rang	0~10°C
Cooling Way	Static
Refrigerant	R134a
Escription	Three Door

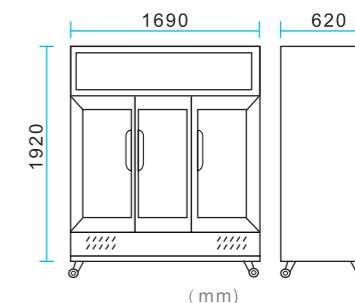



### PROFESSIONAL DESIGN

1. Fast and strong cooling.
2. Double layers hollow glass door.
3. Visual beauty in all directions.
4. Automatic temperature control.
5. Door with lock.
6. Built in high quality plastic dip shelf.
7. LED lighting.
8. Large capacity storage.
9. Static cooling system.
10. Chinese brand compressor.

# 01

## SHOWCASE SERIES

EXPERIENCE LEADING TECHNOLOGY, FOCUS ON LIFE

1. Three-dimensional fresh, enjoy the experience.
2. Effective utilization of land area.
3. High light box and lighting design.
4. Dual display effect, enhance the brand image.
5. Simple fluid lines.
6. Wide transparent glass window design.
7. Exudes a stylish atmosphere, permeated inside and outside the cabinet.
8. Enjoy your cool life every day.

Beverage display cabinet



### ◀ HG-430C

Model	<b>HG-430C</b>
Dimension(mm)	620x645x2050
Voltage Source	220V/50Hz
Input Power	220W
Temperature Rang	0~10°C
Cooling Way	Static
Refrigerant	R134a
Escription	Single Door

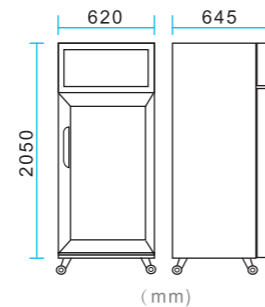

Beverage display cabinet



### ◀ HG-700C / HG-800C

	<b>HG-730C</b>	<b>HG-800C</b>
Model	<b>HG-730C</b>	<b>HG-800C</b>
Dimension(mm)	1060x645x2050	1260x645x2050
Voltage Source	220V/50Hz	220V/50Hz
Input Power	320W	380W
Temperature Rang	0~10°C	0~10°C
Cooling Way	Static	Static
Refrigerant	R134a	R134a
Escription	Two Door	Two Door

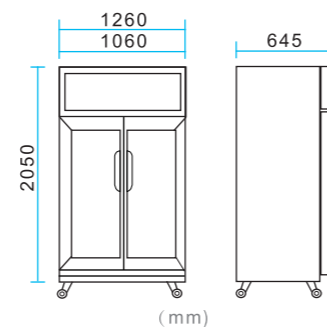

Direct cooling freezer



### ◀ HG-1100C

Model	<b>HG-1100C</b>
Dimension(mm)	1600x645x2050
Voltage Source	220V/50Hz
Input Power	350W
Temperature Rang	0~10°C
Cooling Way	Static
Refrigerant	R134a
Escription	Three Door

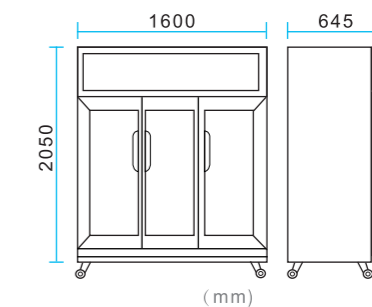

### ENTERPRISE CATALOG//

XingLing has a variety of advanced processing and production equipment, a variety of professional staff at all levels. Jun Jian today for the development of the enterprise to meet customer needs, in order to "continuous innovation, customer satisfaction, rapid improvement, full participation" as the basic quality; with exquisite production technology, strict service spirit and strict testing procedures, make high quality products are pouring out, effectively to meet the different needs of customers.

# SHOWCASE SERIES

In pieces stereo enjoy fresh experience Luxury and beauty light box and cabinet lighting design, Microcomputer temperature control, Simple and fluent line, Pieces of atmospheric SanKaiMen show appearance In pieces and transparent glass window design; Pieces of ice cool and fresh feeling, In pieces the air-filled solid circulation, refrigeration and no dead Angle, In pieces to create perfect stable cold storage space; Your life acme, pieces make you relaxed.



XING LING



# 01

## SHOWCASE SERIES

EXPERIENCE LEADING TECHNOLOGY, FOCUS ON LIFE

1. Three-dimensional fresh, enjoy the experience.
2. Effective utilization of land area.
3. High light box and lighting design.
4. Dual display effect, enhance the brand image.
5. Simple fluid lines.
6. Wide transparent glass window design.
7. Exudes a stylish atmosphere, permeated inside and outside the cabinet.
8. Enjoy your cool life every day.

Air-cooled refrigerator



XING LING  
SHOWCASE

### QUALITY ASSURANCE

For xingling, quality is satisfying customers. We continuously test and complete our products and process flow. We use leading technology facilities, advanced equipment and conscientious attitude to implement the producing and products quality management system. And achieving a comprehensive excellence xingling.

### HG-430AF

Model	<b>HG-430AF</b>
Dimension(mm)	620x645x2050
Voltage Source	220V/50Hz
Input Power	280W
Temperature Rang	0~10°C
Cooling Way	Air Cooling
Refrigerant	R134a
Escription	Single Door

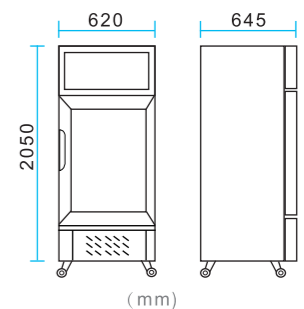

Guangzhou XingLing Kitchen Refrigeration Equipment Co.,Ltd is one of emerging technology company ,Its core is manufacturing technology and refrigeration equipment. We offer not only high-quality refrigeration solutions to customers, but also the most energy-efficient economic environment-friendly refrigeration products (display cabinets, supermarket display cabinets, drug cooler display cabinets, kitchen freezers, cake showcase and so on) to the world. We make our customers to be more competitive with our professional experience. Our equipments are designed with streamlined lines appearance which is nice, elegant and practical. And user-friendly design function makes our products to achieve the perfect fusion from inside to outside. We strictly according to ISO9001 international quality management system, and fused the advanced technology and top technology to provide the accurate recommendations and the most innovative design solutions for customers.



### PROFESSIONAL DESIGN

1. Fast and strong cooling.
2. Double layers hollow glass door.
3. Visual beauty in all directions.
4. Automatic temperature control.
5. Door with lock.
6. Built in high quality plastic dip shelf.
7. LED lighting.
8. Large capacity storage.
9. Static cooling system.
10. Chinese brand compressor.

# 01

## SHOWCASE SERIES

EXPERIENCE LEADING TECHNOLOGY, FOCUS ON LIFE

1. Micro computer automatic temperature control.
2. Imported brand compressor.
3. Professional cooling system.
4. Double layers hollow glass door.
5. LED lighting.
6. Built in high quality plastic dip shelf.
7. High light colour steel design.
8. Three-dimensional advertising light box.

Air-cooled refrigerator



◀ HG-700AF/ HG-800AF

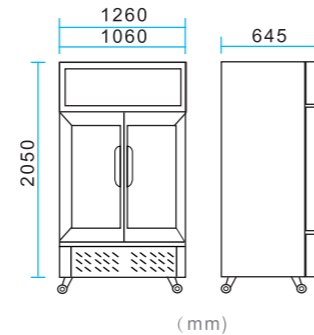

Model	HG-700AF	HG-800AF
Dimension(mm)	1060x645x2050	1260x645x2050
Voltage Source	220V/50Hz	220V/50Hz
Input Power	320W	380W
Temperature Rang	0~10°C	0~10°C
Cooling Way	Air Cooling	Fan Cooling
Refrigerant	R134a	R134a
Escription	Two Door	Two Door

Air-cooled refrigerator



### EXPERIENCE LEADING TECHNOLOGY, FOCUS ON LIFE

1. Imported brand compressor.
2. Highlight colour steel design.
3. Three-dimensional advertising light box.
4. Double layers hollow glass door.
5. Micro computer automatic temperature control.
6. LED lighting.
7. Visual beauty in all directions.
8. Built in high quality plastic dip shelf.

◀ HG-1200

Model	HG-1200
Dimension(mm)	1260x680x2130
Voltage Source	220V/50Hz
Input Power	450W
Temperature Rang	0~10°C
Cooling Way	Air Cooling
Refrigerant	R134a
Escription	Two Door

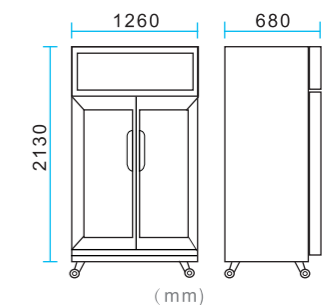

Air-cooled refrigerator



◀ HG-1100AF

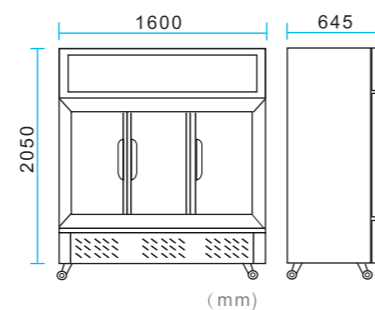

Model	HG-1100AF
Dimension(mm)	1600x645x2050
Voltage Source	220V/50Hz
Input Power	550W
Temperature Rang	0~10°C
Cooling Way	Air Cooling
Refrigerant	R134a
Escription	Three Door

Air-cooled refrigerator



◀ HG-1800

Model	HG-1800
Dimension(mm)	1830x680x2130
Voltage Source	220V/50Hz
Input Power	650W
Temperature Rang	0~10°C
Cooling Way	Air Cooling
Refrigerant	R134a
Escription	Three Door

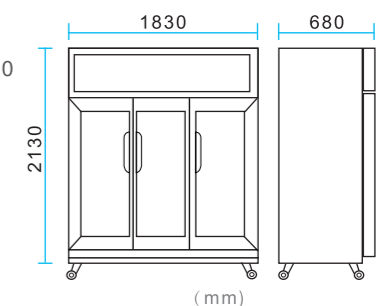

# SHOWCASE SERIES



EXPERIENCE LEADING TECHNOLOGY, FOCUS ON LIFE

XingLing has a variety of advanced processing and production equipment, a variety of professional staff at all levels. Jun Jian today for the development of the enterprise to meet customer needs, in order to "continuous innovation, customer satisfaction, rapid improvement, full participation" as the basic quality; with exquisite production technology, strict service spirit and strict testing procedures, make high quality products are pouring out, effectively to meet the different needs of customers.

# 01

# SHOWCASE SERIES

EXPERIENCE LEADING TECHNOLOGY, FOCUS ON LIFE

1. All stainless steel inside cabinet body
2. Easy to damp parts of the cabinet using stainless steel materials, corrosion resistance, easy to clean
3. Side using high density polyurethane foam, good cooling effect
4. Spacious top design, storage of food and air flow
5. The bottom is equipped with ultra high quality universal casters, mobile easy

Air-cooled refrigerator



## INNOVATION

Xingling products are renowned in the industrial with its outstanding innovation and practical application. We continuously optimize products quality and our service to give our clients greatest satisfaction. We are closely aligned with external collaborations, we also have excellent development teams and the support of educational institutions. Through technology investments and R & D, Our technical planning is to ensuring sustainable products and benefit both customers and end consumers.

### ◀ YP1200B2

Model	<b>YP1200B2</b>
Dimension(mm)	1260x680x2130
Voltage Source	220V/50Hz
Input Power	450W
Temperature Rang	0~10°C
Cooling Way	Air Cooling
Refrigerant	R134a
Escription	Two Door

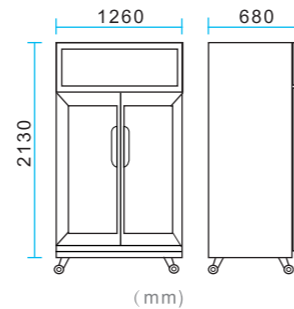

Air-cooled refrigerator



### ◀ YP1800B3

Model	<b>YP1800B3</b>
Dimension(mm)	1830x680x2130
Voltage Source	220V/50Hz
Input Power	650W
Temperature Rang	0~10°C
Cooling Way	Air Cooling
Refrigerant	R134a
Escription	Three Door

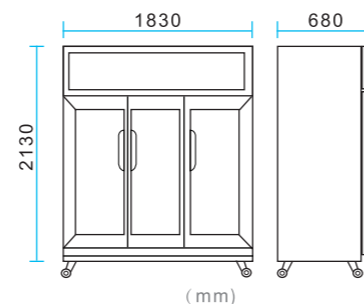

Luxury display cabinet



## Quality Assurance

For xingling, quality is satisfying customers. We continuously test and complete our products and process flow. We use leading technology facilities, advanced equipment and conscientious attitude to implement the producing and products quality management system. And achieving a comprehensive excellence xingling.

### ◀ LPC-1210

Model	<b>LPC-1210</b>
Dimension(mm)	1210x600x2180
Voltage Source	220V/50Hz
Input Power	500W
Temperature Rang	0~10°C
Cooling Way	Air Cooling
Refrigerant	R134a

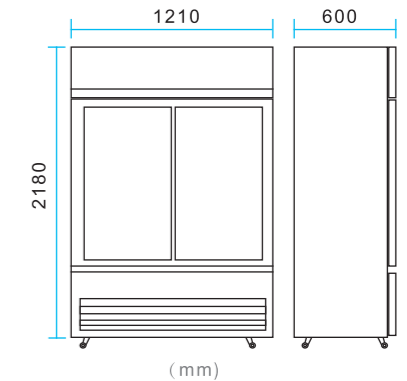

Luxury display cabinet



### ◀ LPC-1810

Model	<b>LPC-1810</b>
Dimension(mm)	1810x600x2180
Voltage Source	220V/50Hz
Input Power	650W
Temperature Rang	0~10°C
Cooling Way	Air Cooling
Refrigerant	R134a

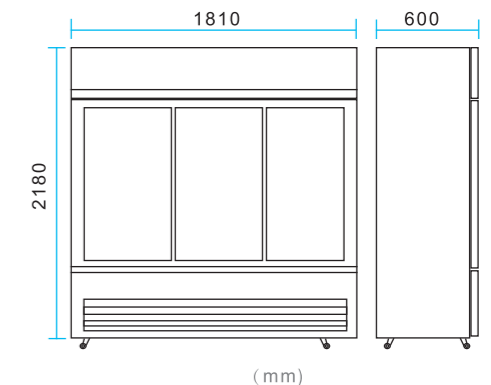

# 02

## SUPERMARKET CABINET

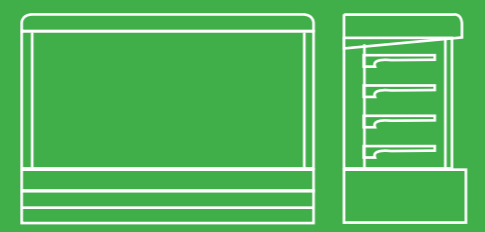

For xingling, quality is satisfying customers. We continuously test and complete our products and process flow. We use leading technology facilities, advanced equipment and conscientious attitude to implement the producing and products quality management system. And achieving a comprehensive excellence xingling.

[GZXINGLING.COM](http://GZXINGLING.COM)

## SUPERMARKET CABINET

The double refrigeration technology solves the technical problem that the single refrigeration system is difficult to overcome, so that no refrigeration blind area is found in the cabinet.  
500mm ultra wide shelf, to provide customers with greater effective display area and more inventory. The OSRAM special lamp tube is arranged at the front of each shelf, and the display effect of the articles in the cabinet is enhanced.  
One piece foam and firm and solid steel foundation make the cabinet better insulated and more durable. Corrosion resistance of color steel plate inner container, increasing the service life of the cabinet.  
The full transparent glass side plate enables the articles in the cabinet to be clear at a glance, and enhances the display effect of the articles in the cabinet.  
The microcomputer controlled digital temperature controller makes the temperature control of the cabinet more accurate and the system more energy efficient.

### RAPID REFRIGERATION

1. Three-dimensional fresh, enjoy the experience.
2. Effective utilization of land area.
3. High light box and lighting design.
4. Dual display effect, enhance the brand image.
5. Simple fluid lines.
6. Wide transparent glass window design.
7. Exudes a stylish atmosphere, permeated inside and outside the cabinet.
8. Enjoy your cool life every day.

## REFRIGERATION EQUIPMENT

EXPERIENCE LEADING TECHNOLOGY, FOCUS ON LIFE

Our equipments are designed with streamlined lines appearance which is nice, elegant and practical. And user-friendly design function makes our products to achieve the perfect fusion from inside to outside. We strictly according to ISO9001 international quality management system, and fused the advanced technology and top technology to provide the accurate recommendations and the most innovative design solutions for customers.

### DELICACY

Exquisite quality, taste fresh life.

### FRESH

See the fresh, xing ling will interpret the price for you.

### POTENCY

Awaken potential of refrigeration, dance out of the new Xing ling.

### IMAGINE

Through the brush of imagination, The glory of the dye xing ling and pentium.

## ENTERPRISE MISSION

EXPERIENCE LEADING TECHNOLOGY, FOCUS ON LIFE

Taste fashion and enjoy comfort! Xing Ling founded five years, with its product and market the constant pursuit of love and potential enterprise charm, gather a large number of excellent management and technical personnel, has a strong professional design team, the international environmental standards in line with the raw and auxiliary materials, and change according to market needs and constantly updated, and establish as a modern management model and standardized production process.





### PROFESSIONAL DESIGN

- 1.Exterior design simple fashion generous, luxury stule.
- 2.Fully open refrigeraton display space, more convenient access to food.
- 3.The ventilation system in the cabinet is perfect and the air is fresh and clean.
- 4.Shelf height can be freely adjusted, flexible planning space.
- 5.LED lighting system.
6. built in high quality plastic shelf.
7. high color steel design.
8. stereo advertising lamp box.

# 02

## SUPERMARKET COUNTER SERIES

EXPERIENCE LEADING TECHONLOGY,FOCUS ON LIFE

1. microcomputer precise temperature control
2. imported famous brand compressor
3. professional refrigeration system
4. double layer insulating glass door
- 5.LED lighting system
6. built in high quality plastic shelf
7. high color steel design
8. stereo advertising lamp box

The wind curtain ark

The wind curtain ark

#### DELICACY

Exquisite quality, taste fresh life.

#### FRESH

See the fresh,xing ling will Interpret the price for you.

#### POTENCY

Awaken potential of refrigeration, dance out of the new Xing ling.

#### IMAGINE

Through the brush of imagination, The glory of the dye xing ling and pentium.



### FMG-15 / FMG-20 / FMG-25

Model	FMG-15	FMG-20	FMG-25
Dimension(mm)	1500x850x2050	2000x850x2050	2500x850x2050
Voltage Source	220V/50Hz	220V/50Hz	220V/50Hz
Input Power	1100W	1500W	1900W
Temperature Rang	2~10°C	2~10°C	2~10°C
Cooling Way	Air Cooling	Air Cooling	Air Cooling
Refrigerant	R134a	R134a	R134a
Escription	Integrated machine	Integrated machine	Integrated machine

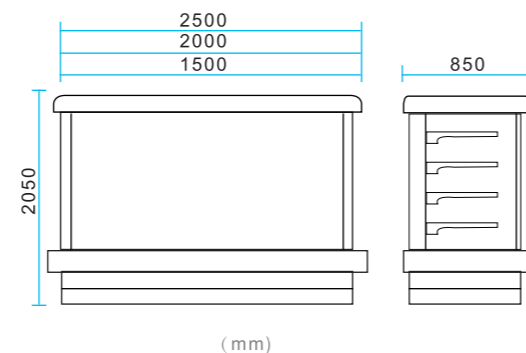

### FMG-15 / FMG-20 / FMG-25

Model	FMG-15	FMG-20	FMG-25
Dimension(mm)	1500x850x2050	2000x850x2050	2500x850x2050
Voltage Source	220V/50Hz	220V/50Hz	220V/50Hz
Input Power	1100W	1500W	1900W
Temperature Rang	2~10°C	2~10°C	2~10°C
Cooling Way	Air Cooling	Air Cooling	Air Cooling
Refrigerant	R134a	R134a	R134a
Escription	Integrated machine	Integrated machine	Integrated machine

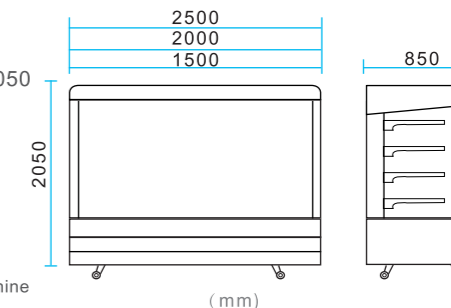

### INDUSTRY REPUTATION BEYOND 86% PEERS

More than ten, the quality of continuous pursuit, from the details of the departure, the completion of self optimization, the quality of persistence, is "Xing Ling" commitment to customers.

### QUALITY ASSURANCE

For xingling,quality is satisfying customers.We continuously test and complete our products and process flow. We use leading technology facilities ,advanced equipment and conscientious attitude to implement the producing and products quality management system.And achieving a comprehensive excellence xingling.





### PROFESSIONAL DESIGN

- 1.Exterior design simple fashion generous, luxury stule.
- 2.Fully open refrigeraton display space, more convenient access to food.
- 3.The ventilation system in the cabinet is perfect and the air is fresh and clean.
- 4.Shelf height can be freely adjusted, flexible planning space.
- 5.LED lighting system.
6. built in high quality plastic shelf.
7. high color steel design.
8. stereo advertising lamp box.

# 02

## SUPERMARKET COUNTER SERIES

EXPERIENCE LEADING TECHONLOGY,FOCUS ON LIFE

1. microcomputer precise temperature control
2. imported famous brand compressor
3. professional refrigeration system
4. double layer insulating glass door
- 5.LED lighting system
6. built in high quality plastic shelf
7. high color steel design
8. stereo advertising lamp box

The wind curtain ark

The wind curtain ark



### FMG-15 / FMG-20 / FMG-25

Model	FMG-15	FMG-20	FMG-25
Dimension(mm)	1500x850x2050	2000x850x2050	2500x850x2050
Voltage Source	220V/50Hz	220V/50Hz	220V/50Hz
Temperature Rang	2~10°C	2~10°C	2~10°C
Cooling Way	Air Cooling	Air Cooling	Air Cooling
Refrigerant	R134a	R134a	R134a
Escription	Separator	Separator	Separator

### INDUSTRY REPUTATION BEYOND 86% PEERS

More than ten, the quality of continuous pursuit, from the details of the departure, the completion of self optimization, the quality of persistence, is "Xing Ling" commitment to customers.



The wind curtain ark



### FMG-15 / FMG-20 / FMG-25

Model	FMG-15	FMG-20	FMG-25
Dimension(mm)	1500x850x2050	2000x850x2050	2500x850x2050
Voltage Source	220V/50Hz	220V/50Hz	220V/50Hz
Input Power	1100W	1500W	1900W
Temperature Rang	2~10°C	2~10°C	2~10°C
Cooling Way	Air Cooling	Air Cooling	Air Cooling
Refrigerant	R134a	R134a	R134a
Escription	Integrated machine	Integrated machine	Integrated machine

### FMG-15 / FMG-20

Model	FMG-15	FMG-20
Dimension(mm)	1500x850x2050	2000x850x2050
Voltage Source	220V/50Hz	220V/50Hz
Input Power	1100W	1500W
Temperature Rang	2~10°C	2~10°C
Cooling Way	Air Cooling	Air Cooling
Refrigerant	R134a	R134a
Escription	Integrated machine	Integrated machine

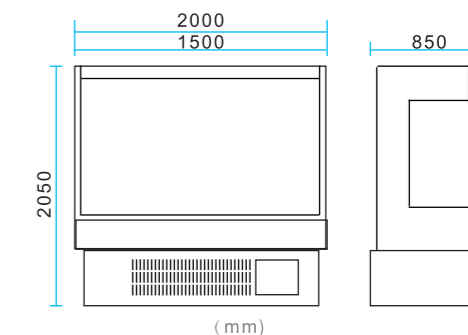

# SUPERMARKET COUNTER SERIES



EXPERIENCE LEADING TECHNOLOGY, FOCUS ON LIFE

XingLing has a variety of advanced processing and production equipment, a variety of professional staff at all levels. Jun Jian today for the development of the enterprise to meet customer needs, in order to "continuous innovation, customer satisfaction, rapid improvement, full participation" as the basic quality; with exquisite production technology, strict service spirit and strict testing procedures, make high quality products are pouring out, effectively to meet the different needs of customers.

# 02

# SUPERMARKET COUNTER SERIES

EXPERIENCE LEADING TECHNOLOGY, FOCUS ON LIFE

1. microcomputer precise temperature control
2. imported famous brand compressor
3. professional refrigeration system
4. double layer insulating glass door
5. LED lighting system
6. built in high quality plastic shelf
7. high color steel design
8. stereo advertising lamp box

## The wind curtain ark

## Meat ark



- ◎ **DELICACY**  
Exquisite quality, taste fresh life.
- ◎ **FRESH**  
See the fresh, xing ling will Interpret the price for you.
- ◎ **POTENCY**  
Awaken potential of refrigeration, dance out of the new Xing ling.
- ◎ **IMAGINE**  
Through the brush of imagination, The glory of the dye xing ling and pentium.

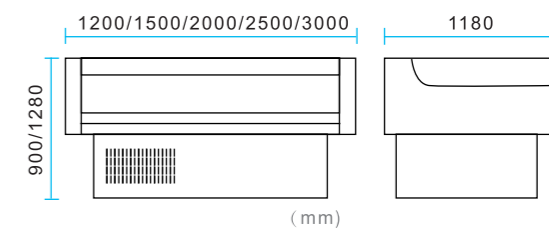

### INNOVATION

Xingling products are renowned in the industrial with its outstanding innovation and practical application. We continuously optimize products quality and our service to give our clients greatest satisfaction. We are closely aligned with external collaborations, we also have excellent development teams and the support of educational institutions. Through technology investments and R & D, Our technical planning is to ensuring sustainable products and benefit both customers and end consumers.

Model	FMG-15	FMG-20
Dimension(mm)	1500x850x2050	2000x850x2050
Voltage Source	220V/50Hz	220V/50Hz
Input Power	1100W	1500W
Temperature Rang	2~10°C	2~10°C
Cooling Way	Air Cooling	Air Cooling
Refrigerant	R134a	R134a
Escription	Integrated machine	Integrated machine

Model	XLRG-12	XLRG-15	XLRG-20	XLRG-25	XLRG-30
Dimension(mm)	1200x1180x900	1500x1180x900	2000x1180x900	2500x1180x900	3000x1180x1280
Voltage Source	220V/50Hz	220V/50Hz	220V/50Hz	220V/50Hz	220V/50Hz
Input Power	450W	580W	750W	1100W	1500W
Temperature Rang	-2~8°C	-2~8°C	-2~8°C	-2~8°C	-2~8°C
Cooling Way	Air Cooling	Air Cooling	Air Cooling	Air Cooling	Air Cooling
Refrigerant	R134a	R134a	R134a	R134a	R134a
Escription	Integrated machine	Integrated machine	Integrated machine	Integrated machine	Integrated machine

# 03

## CAKE CABINET SERIES



For xingling, quality is satisfying customers. We continuously test and complete our products and process flow. We use leading technology facilities, advanced equipment and conscientious attitude to implement the producing and products quality management system. And achieving a comprehensive excellence xingling.

# XING LING

[GZXINGLING.COM](http://GZXINGLING.COM)

## CAKE CABINET SERIES

As with freezing force, the power consumption of the cake freezer is also a very important performance index. However, to achieve the best effect of preservation, it is not enough to reduce the power consumption. It is necessary to optimize the structure and the refrigeration design. Xing Ling by increasing the insulation layer (a corresponding increase in the cost) this kind of simple measures to achieve the purpose of saving electricity can also be through the use of new technologies to improve energy efficiency achievements, it is not one-sided emphasis on the more power the better".

In order to have a variety of fresh cake cabinet, storage, display, etc., the overall structure of the cake cabinet and all the disassembling and assembling parts, all uses toughened glass, which guarantees the display effect, and to ensure that the glass is broken will not hurt, does not use any glue materials, a screwdriver can complete the entire showcase disassembly. Easy disassembly and assembly, handling, moving, pushing and pulling, etc..

## REFRIGERATION EQUIPMENT

EXPERIENCE LEADING TECHNOLOGY, FOCUS ON LIFE

Our equipments are designed with streamlined lines appearance which is nice, elegant and practical. And user-friendly design function makes our products to achieve the perfect fusion from inside to outside. We strictly according to ISO9001 international quality management system, and fused the advanced technology and top technology to provide the accurate recommendations and the most innovative design solutions for customers.

## ENTERPRISE MISSION

EXPERIENCE LEADING TECHNOLOGY, FOCUS ON LIFE

Taste fashion and enjoy comfort! Xing Ling founded five years, with its product and market the constant pursuit of love and potential enterprise charm, gather a large number of excellent management and technical personnel, has a strong professional design team, the international environmental standards in line with the raw and auxiliary materials, and change according to market needs and constantly updated, and establish as a modern management model and standardized production process.

### RAPID REFRIGERATION

1. Three-dimensional fresh, enjoy the experience.
2. Effective utilization of land area.
3. High light box and lighting design.
4. Dual display effect, enhance the brand image.
5. Simple fluid lines.
6. Wide transparent glass window design.
7. Exudes a stylish atmosphere, permeated inside and outside the cabinet.
8. Enjoy your cool life every day.

### DELICACY

Exquisite quality, taste fresh life.

### FRESH

See the fresh, xing ling will interpret the price for you.

### POTENCY

Awaken potential of refrigeration, dance out of the new Xing ling.

### IMAGINE

Through the brush of imagination, The glory of the dye xing ling and pentium.



## PROFESSIONAL DESIGN

1. Exterior design simple fashion generous, luxury stule.
2. Fully open refrigeraton display space, more convenient access to food.
3. The ventilation system in the cabinet is perfect and the air is fresh and clean.
4. Shelf height can be freely adjusted, flexible planning space.
5. LED lighting system.
6. built in high quality plastic shelf.
7. high color steel design.
8. stereo advertising lamp box.

# 03

## CAKE CABINET SERIES

EXPERIENCE LEADING TECHONLOGY, FOCUS ON LIFE

1. microcomputer precise temperature control
2. imported famous brand compressor
3. professional refrigeration system
4. double layer insulating glass door
5. LED lighting system
6. built in high quality plastic shelf
7. high color steel design
8. stereo advertising lamp box

Ice cream cabinet



### ◀ YP-1250 / YP-1500

Model	YP-1250	YP-1500
Dimension(mm)	1250x1100x1310	1550x1100x1310
Voltage Source	220V/50Hz	220V/50Hz
Input Power	600W	800W
Temperature Rang	-22°C	-22°C
Cooling Way	Air Cooling	Air Cooling
Refrigerant	R22	R22
Escription	Ice Cream Cabinet	Ice Cream Cabinet

Cake cabinet



### ◀ XL-855

Model	XL-855
Dimension(mm)	855x500x780
Voltage Source	220V/50Hz
Input Power	200W
Temperature Rang	0~10°C
Cooling Way	Air Cooling
Refrigerant	R134a

Ice cream cabinet



### ◀ YP-1250A / YP-1500A

Model	YP-1250A	YP-1500A
Dimension(mm)	1200x910x1350	1500x910x1350
Voltage Source	220V/50Hz	220V/50Hz
Input Power	600W	800W
Temperature Rang	-22°C	-22°C
Cooling Way	Air Cooling	Air Cooling
Refrigerant	R22	R22
Escription	Ice Cream Cabinet	Ice Cream Cabinet

Cake cabinet



### ◀ XL-1200 / XL-1500

Model	XL-1200	XL-1500
Dimension(mm)	1200x760x1240	1500x760x1240
Voltage Source	220V/50Hz	220V/50Hz
Input Power	350W	450W
Temperature Rang	4~8°C	4~8°C
Cooling Way	Air Cooling	Air Cooling
Refrigerant	R134a	R134a

Cake cabinet



### ◀ XL-1200A / XL-1500A / XL-1800A

Model	XL-1200A	XL-1500A	XL-1800A
Dimension(mm)	1200x700x1200	1500x700x1200	1800x700x1200
Voltage Source	220V/50Hz	220V/50Hz	220V/50Hz
Input Power	350W	450W	550W
Temperature Rang	4~8°C	4~8°C	4~8°C
Cooling Way	Air Cooling	Air Cooling	Air Cooling
Refrigerant	R134a	R134a	R134a



### PROFESSIONAL DESIGN

- 1.Full display glass window
- 2.Front glass Defrost design
- 3.Curved glass design
- 4.Automatic defrost
- 5.Fan cooling cycle refrigeration technology
- 6.LED lighting
- 7.Microcomputer control
- 8.Precision temperature controller
- 9.Universal casters.
- 10.High efficiency heat exchanger
- 11.brand compressor
- 12.High efficiency evaporator

## CAKE CABINET SERIES

EXPERIENCE LEADING TECHNOLOGY, FOCUS ON LIFE

# 03

1. Incremental laminar flow optimization air curtain, high efficiency and energy saving
2. Advanced back blow refrigeration system, temperature uniformity
3. Precision Defrost automatic control, stable performance
4. The Defrost process adopts double control of the temperature and time, to save energy
5. Nice looking and luxury appearance
6. Appearance with high quality, non deformation, non deformation, corrosion resistance, seamless splicing.

Cake cabinet



◀ XL-1200C / XL-1500C / XL-1800C

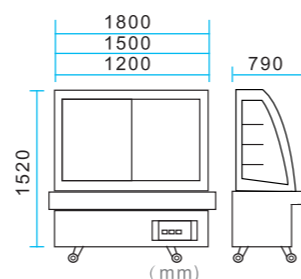

Model	XL-1200C	XL-1500C	XL-1800C
Dimension(mm)	1200x790x1520	1500x790x1520	1800x790x1520
Voltage Source	220V/50Hz	220V/50Hz	220V/50Hz
Input Power	350W	450W	550W
Temperature Rang	3~10°C	3~10°C	3~10°C
Cooling Way	Air Cooling	Air Cooling	Air Cooling
Refrigerant	R134a	R134a	R134a

Cake cabinet

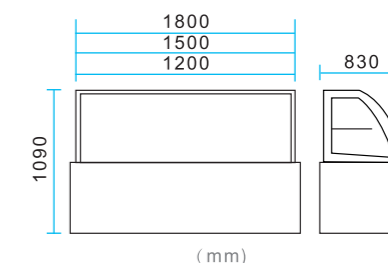

◀ XL-1200A2 / XL-1500A2 / XL-1800A2



Model	XL-1200A2	XL-1500A2	XL-1800A2
Dimension(mm)	1200x830x1090	1500x830x1090	1800x830x1090
Voltage Source	220V/50Hz	220V/50Hz	220V/50Hz
Input Power	350W	450W	550W
Temperature Rang	4~8°C	4~8°C	4~8°C
Cooling Way	Air Cooling	Air Cooling	Air Cooling
Refrigerant	R134a	R134a	R134a

Cake cabinet

### QUALITY ASSURANCE

For xingling, quality is satisfying customers. We continuously test and complete our products and process flow. We use leading technology facilities, advanced equipment and conscientious attitude to implement the producing and products quality management system. And achieving a comprehensive excellence xingling.



◀ XL-1200A1 / XL-1500A1 / XL-1800A1

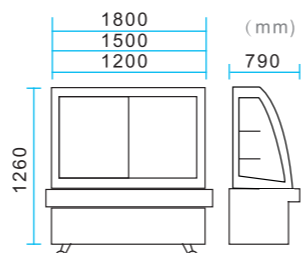

Model	XL-1200A1	XL-1500A1	XL-1800A1
Dimension(mm)	1200x790x1260	1500x790x1260	1800x790x1260
Voltage Source	220V/50Hz	220V/50Hz	220V/50Hz
Input Power	350W	450W	550W
Temperature Rang	3~10°C	3~10°C	3~10°C
Cooling Way	Air Cooling	Air Cooling	Air Cooling
Refrigerant	R134a	R134a	R134a

Cake cabinet

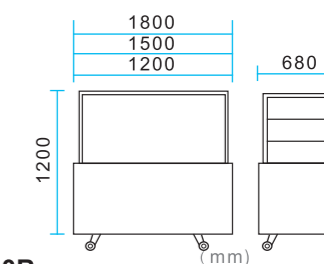

◀ XL-1200B / XL-1500B / XL-1800B

Model	XL-1200B	XL-1500B	XL-1800B
Dimension(mm)	1200x680x1200	1500x680x1200	1800x680x1200
Voltage Source	220V/50Hz	220V/50Hz	220V/50Hz
Input Power	350W	450W	550W
Temperature Rang	4~8°C	4~8°C	4~8°C
Cooling Way	Air Cooling	Air Cooling	Air Cooling
Refrigerant	R134a	R134a	R134a



# 03

## CAKE CABINET SERIES

EXPERIENCE LEADING TECHNOLOGY, FOCUS ON LIFE

1. Full display glass window
2. Front glass Defrost design
3. Curved glass design
4. Automatic defrost
5. Fan cooling cycle refrigeration technology
6. LED lighting
7. Microcomputer control
8. Precision temperature controller
9. Universal casters.
10. High efficiency heat exchanger
11. brand compressor
12. High efficiency evaporator

Cake cabinet

### PROFESSIONAL DESIGN

Our equipments are designed with streamlined lines appearance which is nice, elegant and practical. And user-friendly design function makes our products to achieve the perfect fusion from inside to outside. We strictly according to ISO9001 international quality management system, and fused the advanced technology and top technology to provide the accurate recommendations and the most innovative design solutions for customers.



#### ◀ XT-1200A

Model	<b>XT-1200A</b>
Dimension(mm)	1200x700x2000
Voltage Source	220V/50Hz
Input Power	550W
Temperature Rang	4~8°C
Cooling Way	Air Cooling
Refrigerant	R134a

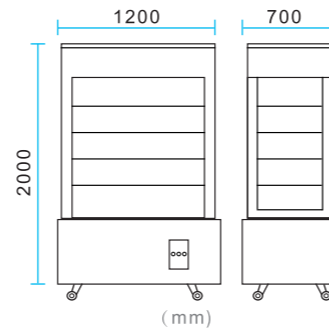

Cake cabinet



#### ◀ XT-1500A

Model	<b>XT-1500A</b>
Dimension(mm)	1500x700x2000
Voltage Source	220V/50Hz
Input Power	650W
Temperature Rang	4~8°C
Cooling Way	Air Cooling
Refrigerant	R134a

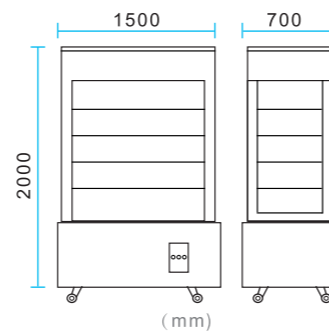

Cake cabinet



#### ◀ XT-1200A1

Model	<b>XT-1200A1</b>
Dimension(mm)	1200x720x1320
Voltage Source	220V/50Hz
Input Power	480W
Temperature Rang	4~8°C
Cooling Way	Air Cooling
Refrigerant	R134a

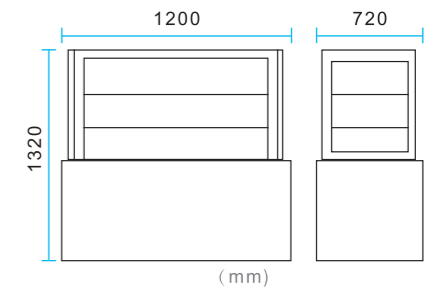

Cake cabinet



#### ◀ XT-1500A1

Model	<b>XT-1500A1</b>
Dimension(mm)	1500x720x1320
Voltage Source	220V/50Hz
Input Power	580W
Temperature Rang	4~8°C
Cooling Way	Air Cooling
Refrigerant	R134a

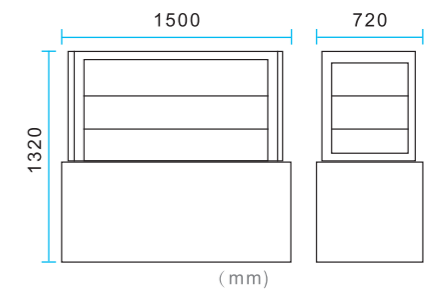



# 03

## MATCH DISH CHEST

EXPERIENCE LEADING TECHNOLOGY, FOCUS ON LIFE

- 1. Full display glass window
- 2. Front glass Defrost design
- 3. Curved glass design
- 4. Automatic defrost
- 5. Fan cooling cycle refrigeration technology
- 6. LED lighting
- 7. Microcomputer control
- 8. Precision temperature controller
- 9. Universal casters.
- 10. High efficiency heat exchanger
- 11. brand compressor
- 12. High efficiency evaporator

### Luxury cooked food cabinets

#### XINGLING ENTERPRISE

XingLing has a variety of advanced processing and production equipment, a variety of professional staff at all levels. XingLing today for the development of the enterprise to meet customer needs, in order to "continuous innovation, customer satisfaction, rapid improvement, full participation" as the basic quality; with exquisite production technology, strict service spirit and strict testing procedures, make high quality products are pouring out, effectively to meet the different needs of customers.



### Match dish chest



#### DELICACY

Exquisite quality, taste fresh life.

#### FRESH

See the fresh, xing ling will Interpret the price for you.

#### POTENCY

Awaken potential of refrigeration, dance out of the new Xing ling.

#### IMAGINE

Through the brush of imagination, The glory of the dye xing ling and pentium.

#### SSG-1500 / SSG-1800

Model	SSG-1500	SSG-1800
Dimension(mm)	1500x1000x1260	1800x1000x1260
Voltage Source	220V/50Hz	220V/50Hz
Input Power	650W	750W
Temperature Rang	2~8°C	2~8°C
Cooling Way	Air Cooling	Air Cooling
Refrigerant	R134a	R134a

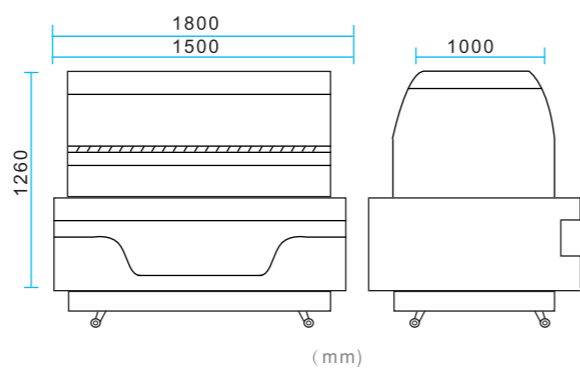

#### ▲ PCG-1000 / PCG-1500 / PCG-2000

Model	PCG-1000	PCG-1500	PCG-2000
Dimension(mm)	1000x800x1680	1500x800x1680	2000x800x1680
Voltage Source	220V/50Hz	220V/50Hz	220V/50Hz
Input Power	400W	500W	700W
Temperature Rang	2~8°C	2~8°C	2~8°C
Cooling Way	Air Cooling	Air Cooling	Air Cooling
Refrigerant	R134a	R134a	R134a

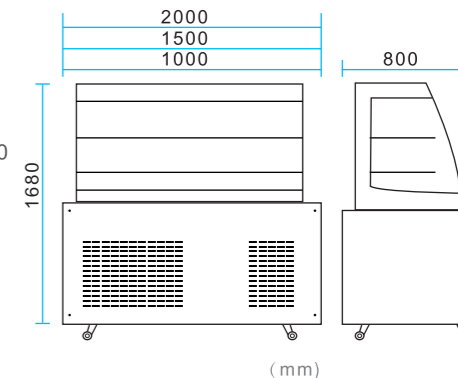



[GZXINGLING.COM](http://GZXINGLING.COM)

## KITCHEN CABINET SERIES

Freezer is another name for refrigerators and freezers. The quality of all refrigerator evaporation tube are made of high quality copper tube processing and wide profile. The stainless steel plate has a smooth surface, uniform thickness and proper thickness, which ensures the long service life, and makes the appearance of the refrigerator smooth and firm. Brass than aluminum or composite tube heat transfer effect, better corrosion resistance, high quality copper coil tube with high cleanliness, pipe joint less advantages, can effectively prevent the failure of internal leakage or blockage of the refrigeration system. The circular tube is treated as a rectangle, so that the evaporating tube contacts the cold passing liner and becomes a surface contact from point contact, thereby enlarging the delivery area and speeding up the refrigeration rate.

### RAPID REFRIGERATION

- 1.Three-dimensional fresh,enjoy the experience
- 2.Effective utilization of land area.
- 3.High light box and lighting design.
- 4.Dual display effect,enhance the brand image.
- 5.Simple fluid lines.
- 6.Wide transparent glass window design.
- 7.Exudes a stylish atmosphere,permeated inside and outside the cabinet.
- 8.Enjoy your cool life every day.

## KITCHEN CABINET SERIES

# 4



## REFRIGERATION EQUIPMENT

◎ EXPERIENCE LEADING TECHONLOGY,FOCUS ON LIFE

Our equipments are designed with streamlined lines appearance which is nice,elegant and practical.And user-friendly design function makes our products to achieve the perfect fusion from inside to outside.We strictly according to ISO9001 international quality management system, and fused the advanced technology and top technology to provide the accurate recommendations and the most innovative design solutions for customers.

### DELICACY

Exquisite quality, taste fresh life.

### FRESH

See the fresh,xing ling will Interpret the price for you.

### POTENCY

Awaken potential of refrigeration, dance out of the new Xing ling.

### IMAGINE

Through the brush of imagination, The glory of the dye xing ling and pentium.

## ENTERPRISE MISSION

◎ EXPERIENCE LEADING TECHONLOGY,FOCUS ON LIFE

Taste fashion and enjoy comfort! Xing Ling founded five years, with its product and market the constant pursuit of love and potential enterprise charm, gather a large number of excellent management and technical personnel, has a strong professional design team, the international environmental standards in line with the raw and auxiliary materials, and change according to market needs and constantly updated, and establish as a modern management model and standardized production process.

For xingling,quality is satisfying customers.We continuously test and complete our products and process flow. We use leading technology facilities ,advanced equipment and conscientious attitude to implement the producing and products quality management system.And achieving a comprehensive excellence xingling.



### PROFESSIONAL DESIGN

- 1.Exterior design simple fashion generous, luxury stule.
- 2.Fully open refrigeraton display space, more convenient access to food.
- 3.The ventilation system in the cabinet is perfect and the air is fresh and clean.
- 4.Shelf height can be freely adjusted, flexible planning space.
- 5.LED lighting system.
6. built in high quality plastic shelf.
7. high color steel design.
8. stereo advertising lamp box.

# 04

## KITCHEN CABINET

EXPERIENCE LEADING TECHONLOGY,FOCUS ON LIFE

- 1.Internal round sink type design.
- 2.Brand compressor.
- 3.High density polyurethane foam.
- 4.Humanized handle design.
- 5.Electronic display.
- 6.Precision temperature controller.
- 7.High quality bearing shelf.
- 8.Universal casters.
- 9.Can place standard GN pans.
- 10.Simple fashion design.

Direct cooling kitchen cabinet

Air cooled kitchen cabinet



### QUALITY ASSURANCE

For xingling, quality is satisfying customers. We continuously test and complete our products and process flow. We use leading technology facilities, advanced equipment and conscientious attitude to implement the producing and products quality management system. And achieving a comprehensive excellence xingling.

#### ◀ KD0.5L2T

Model	<b>KD0.5L2T</b>
Dimension(mm)	610x700x1900
Voltage Source	220V/50Hz
Input Power	190W
Temperature Rang	-6~-12 / 0~10°C
Cooling Way	Static
Refrigerant	R134a

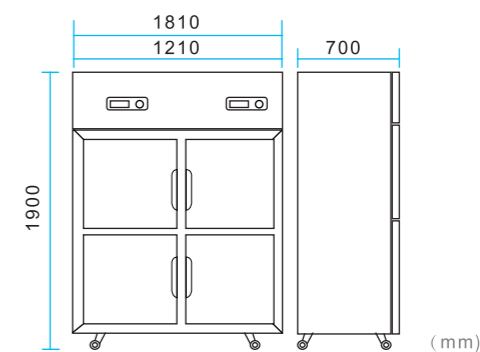
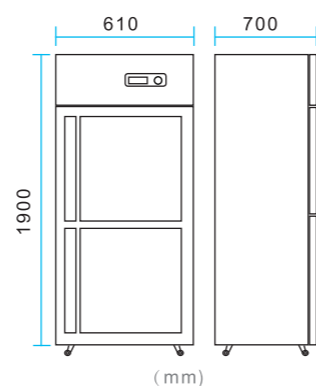

#### ◀ KCD1.0L4B / KCD1.6L6B

Model	<b>KCD1.0L4B</b>	<b>KCD1.6L6B</b>
Dimension(mm)	1210x700x1900	1810x700x1900
Voltage Source	220V/50Hz	220V/50Hz
Input Power	280W	380W
Temperature Rang	0~10°C / 0~10°C	0~10°C / 0~10°C
Cooling Way	Air Cooling	Air Cooling
Refrigerant	R134a	R134a
Escription	Four Door	Six Door

Direct cooling kitchen cabinet

Direct cooling kitchen cabinet



#### ◀ KCD1.0L4T

Model	<b>KCD1.0L4T</b>
Dimension(mm)	1210x700x1900
Voltage Source	220V/50Hz
Input Power	370W
Temperature Rang	-6~-12 / 0~10°C
Cooling Way	Static
Refrigerant	R134a

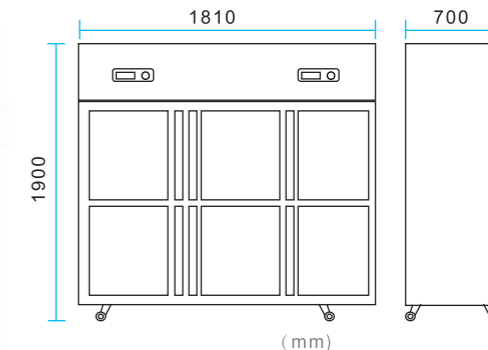
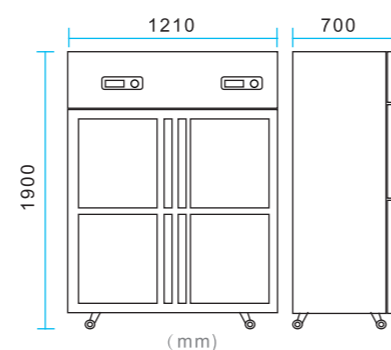

#### ◀ KCD1.6L6T

Model	<b>KCD1.6L6T</b>
Dimension(mm)	1810x700x1900
Voltage Source	220V/50Hz
Input Power	490W
Temperature Rang	-6~-12 / 0~10°C
Cooling Way	Static
Refrigerant	R134a



### PROFESSIONAL DESIGN

- 1.Exterior design simple fashion generous, luxury stule.
- 2.Fully open refrigeraton display space, more convenient access to food.
- 3.The ventilation system in the cabinet is perfect and the air is fresh and clean.
- 4.Shelf height can be freely adjasted, flexible planning space.
- 5.LED lighting system.
6. built in high quality plastic shelf.
7. high color steel design.
8. stereo advertising lamp box.

# 04

## KITCHEN CABINET

EXPERIENCE LEADING TECHONLOGY,FOCUS ON LIFE

- 1.Brand compressor.
- 2.High density polyurethane foam.
- 3.Humanized handle design.
- 4.Electronic display.
- 5.Precision temperature controller.
- 6.High quality bearing shelf.
- 7.Universal casters.
- 8.Can place standard GN pans.

Direct cooling kitchen cabinet

Direct cooling kitchen cabinet



### QUALITY ASSURANCE

For xingling, quality is satisfying customers. We continuously test and complete our products and process flow. We use leading technology facilities, advanced equipment and conscientious attitude to implement the producing and products quality management system. And achieving a comprehensive excellence xingling.

#### ◀ KD1.0B2T

Model	<b>KD1.0B2T</b>
Dimension(mm)	1210x700x1900
Voltage Source	220V/50Hz
Input Power	220W
Temperature Rang	0~10°C
Cooling Way	Static
Refrigerant	R134a

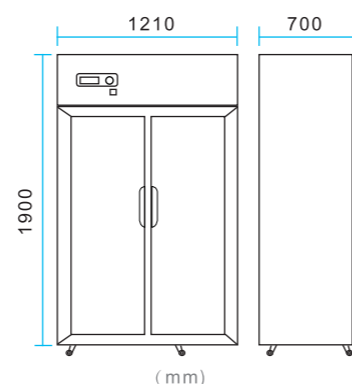

#### ◀ KCD1.0L2B2T

Model	<b>KCD1.0L2B2T</b>
Dimension(mm)	1210x700x1900
Voltage Source	220V/50Hz
Input Power	370W
Temperature Rang	-6~-12 / 0~10°C
Cooling Way	Static
Refrigerant	R134a

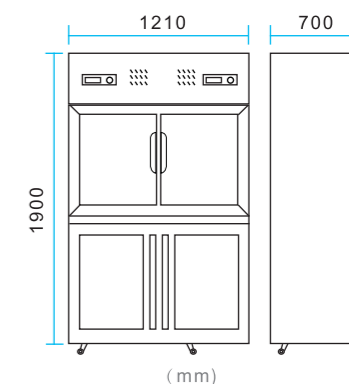

Direct cooling kitchen cabinet

Direct cooling kitchen cabinet



#### ◀ KD1.6B3T

Model	<b>KD1.6B3T</b>
Dimension(mm)	1810x700x1900
Voltage Source	220V/50Hz
Input Power	490W
Temperature Rang	0~10°C
Cooling Way	Static
Refrigerant	R134a

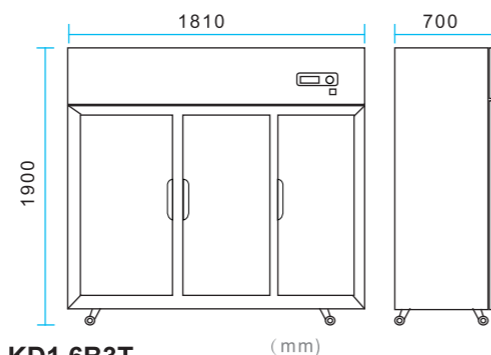

#### ◀ KCD1.6L3B3T

Model	<b>KCD1.6L3B3T</b>
Dimension(mm)	1810x700x1900
Voltage Source	220V/50Hz
Input Power	490W
Temperature Rang	-6~-12 / 0~10°C
Cooling Way	Static
Refrigerant	R134a

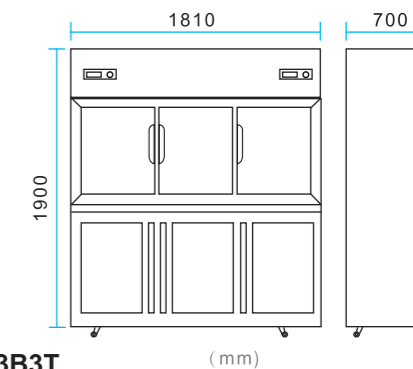

# KITCHEN CABINET

In pieces stereo enjoy fresh experience Luxury and beauty light box and cabinet lighting design, Microcomputer temperature control, Simple and fluent line, Pieces of atmospheric SanKaiMen show appearance In pieces and transparent glass window design, Pieces of ice cool and fresh feeling, In pieces the air-filled solid circulation, refrigeration and no dead Angle, In pieces to create perfect stable cold storage space; Your life acme, pieces make you relaxed.



XING LING



# 04

## KITCHEN CABINET

EXPERIENCE LEADING TECHNOLOGY, FOCUS ON LIFE

- 1.Brand compressor.
- 2.High density polyurethane foam.
- 3.Humanized handle design.
- 4.Electronic display.
- 5.Precision temperature controller.
- 6.High quality bearing shelf.
- 7.Universal casters.
- 8.Can place standard GN pans.

### Deluxe workbench

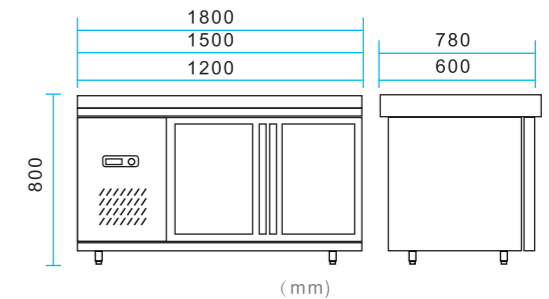

TC0.2L2T / TC0.25L2T / TC0.4L2T

### QUALITY ASSURANCE

For xingling, quality is satisfying customers. We continuously test and complete our products and process flow. We use leading technology facilities, advanced equipment and conscientious attitude to implement the producing and products quality management system. And achieving a comprehensive excellence xingling.

Model	TC0.2L2T	TC0.25L2T	TC0.4L2T
Dimension(mm)	1200x600x800	1500x600x800	1800x780x800
Voltage Source	220V/50Hz	220V/50Hz	220V/50Hz
Input Power	160W	160W	160W
Temperature Rang	0~10°C	0~10°C	0~10°C
Cooling Way	Static	Static	Static
Refrigerant	R134a	R134a	R134a

### Deluxe workbench

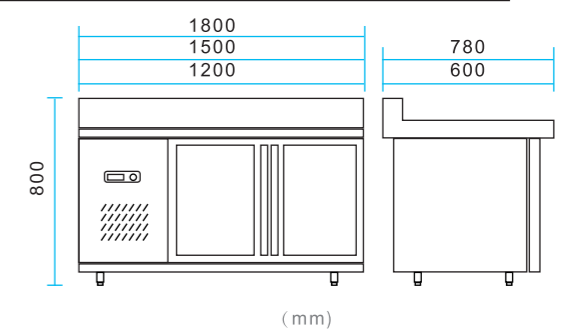

TC0.25L2T / TC0.4L2T

Model	TC0.2L2T	TC0.25L2T	TC0.4L2T
Dimension(mm)	1200x600x800	1500x600x800	1800x780x800
Voltage Source	220V/50Hz	220V/50Hz	220V/50Hz
Input Power	160W	160W	160W
Temperature Rang	0~10°C	0~10°C	0~10°C
Cooling Way	Static	Static	Static
Refrigerant	R134a	R134a	R134a

Guangzhou XingLing Kitchen Refrigeration Equipment Co.,Ltd is one of emerging technology company ,Its core is manufacturing technology and refrigeration equipment. We offer not only high-quality refrigeration solutions to customers, but also the most energy-efficient economic environment-friendly refrigeration products (display cabinets, supermarket display cabinets, drug cooler display cabinets, kitchen freezers, cake showcase and so on) to the world. We make our customers to be more competitive with our professional experience. Our equipments are designed with streamlined lines appearance which is nice, elegant and practical. And user-friendly design function makes our products to achieve the perfect fusion from inside to outside. We strictly according to ISO9001 international quality management system, and fused the advanced technology and top technology to provide the accurate recommendations and the most innovative design solutions for customers.



### PROFESSIONAL DESIGN

- 1.Exterior design simple fashion generous, luxury stule.
- 2.Fully open refrigeraton display space, more convenient access to food.
- 3.The ventilation system in the cabinet is perfect and the air is fresh and clean.
- 4.Shelf height can be freely adjusted, flexible planning space.
- 5.LED lighting system.
6. built in high quality plastic shelf.
7. high color steel design.
8. stereo advertising lamp box.

# 04

## KITCHEN CABINET

EXPERIENCE LEADING TECHONLOGY,FOCUS ON LIFE

- 1.High quality casters
- 2.Humanized design
- 3.Can place standard Giv pans
- 4.Internal round sink type design
- 5.High density polyurethane foam
- 6.High quality stainless steel body
- 7.Precision temperature controller
- 8.High quality bearing shelf

### Four door cupboard



### QUALITY ASSURANCE

For xingling, quality is satisfying customers. We continuously test and complete our products and process flow. We use leading technology facilities, advanced equipment and conscientious attitude to implement the producing and products quality management system. And achieving a comprehensive excellence xingling.

#### ◀ KCD1.0L4G

Model	<b>KCD1.0L4G</b>
Dimension(mm)	1210x700x1900
Voltage Source	220V/50Hz
Input Power	370W
Temperature Rang	-6~-12 / 0~10°C
Cooling Way	Static
Refrigerant	R134a

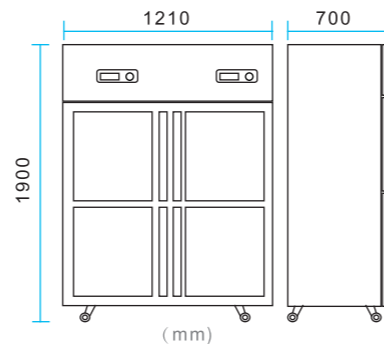

### Six door cupboard



#### ◀ KCD1.6L6G

Model	<b>KCD1.6L6G</b>
Dimension(mm)	1810x700x1900
Voltage Source	220V/50Hz
Input Power	490W
Temperature Rang	-6~-12 / 0~10°C
Cooling Way	Static
Refrigerant	R134a

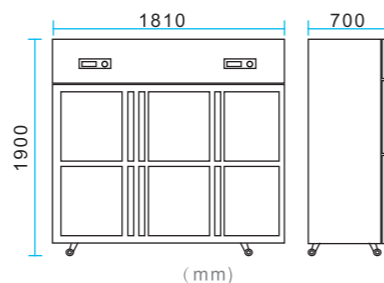

### Deluxe workbench



#### ◀ TC0.25L2G / TC0.4L2G

Model	<b>TC0.25L2G</b>	<b>TC0.4L2G</b>
Dimension(mm)	1500x600x800	1800x780x800
Voltage Source	220V/50Hz	220V/50Hz
Input Power	175W	175W
Temperature Rang	0~10°C	0~10°C
Cooling Way	Static	Static
Refrigerant	R134a	R134a

### Deluxe workbench



#### ◀ TC0.25B2T / TC0.4B2T

Model	<b>TC0.25B2T</b>	<b>TC0.4B2T</b>
Dimension(mm)	1500x800x900	1800x800x900
Voltage Source	220V/50Hz	220V/50Hz
Input Power	175W	175W
Temperature Rang	0~10°C	0~10°C
Cooling Way	Static	Static
Refrigerant	R134a	R134a

### Deluxe workbench



#### ◀ TC0.25L2G

Model	<b>TC0.25L2G</b>
Dimension(mm)	1500x600x800
Voltage Source	220V/50Hz
Input Power	160W
Temperature Rang	-5~-5°C
Cooling Way	Static
Refrigerant	R134a



### PROFESSIONAL DESIGN

- 1.Exterior design simple fashion generous, luxury stule.
- 2.Fully open refrigeraton display space, more convenient access to food.
- 3.The ventilation system in the cabinet is perfect and the air is fresh and clean.
- 4.Shelf height can be freely adjusted, flexible planning space.
- 5.LED lighting system.
6. built in high quality plastic shelf.
7. high color steel design.
8. stereo advertising lamp box.

# 04

## KITCHEN CABINET

EXPERIENCE LEADING TECHONLOGY,FOCUS ON LIFE

- 1.High quality casters
- 2.Humanized design
- 3.Can place standard Giv pans
- 4.Internal round sink type design
- 5.High density polyurethane foam
- 6.High quality stainless steel body
- 7.Precision temperature controller
- 8.High quality bearing shelf

### Four door cupboard



#### QUALITY ASSURANCE

For xingling, quality is satisfying customers. We continuously test and complete our products and process flow. We use leading technology facilities, advanced equipment and conscientious attitude to implement the producing and products quality management system. And achieving a comprehensive excellence xingling.

#### ◀ KCD1.0L4GG

Model	<b>KCD1.0L4GG</b>
Dimension(mm)	1210x700x1900
Voltage Source	220V/50Hz
Input Power	290W
Temperature Rang	-6~-12 / 0~10°C
Cooling Way	Static
Refrigerant	R134a

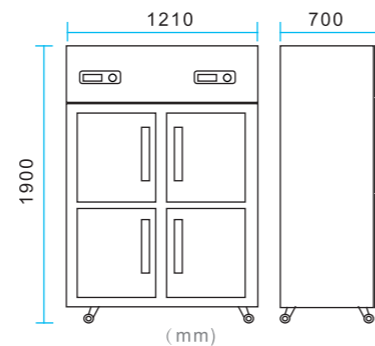

### Six door cupboard



#### ◀ KCD1.6L6GG

Model	<b>KCD1.6L6GG</b>
Dimension(mm)	1810x700x1900
Voltage Source	220V/50Hz
Input Power	390W
Temperature Rang	-6~-12 / 0~10°C
Cooling Way	Static
Refrigerant	R134a

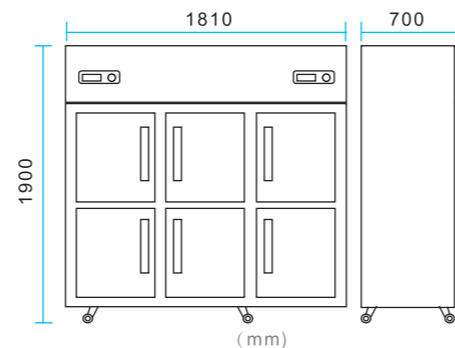

### Deluxe workbench

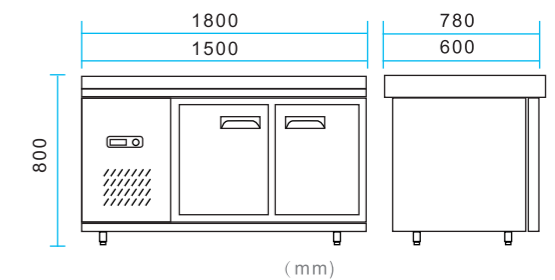

#### ◀ TC0.25L2GG / TC0.4L2GG

Model	<b>TC0.25L2GG</b>	<b>TC0.4L2GG</b>
Dimension(mm)	1500x600x800	1800x780x800
Voltage Source	220V/50Hz	220V/50Hz
Input Power	200W	200W
Temperature Rang	0~10°C	0~10°C
Cooling Way	Static	Static
Refrigerant	R134a	R134a

#### QUALITY ASSURANCE

For xingling, quality is satisfying customers. We continuously test and complete our products and process flow. We use leading technology facilities, advanced equipment and conscientious attitude to implement the producing and products quality management system. And achieving a comprehensive excellence xingling.

### Deluxe workbench

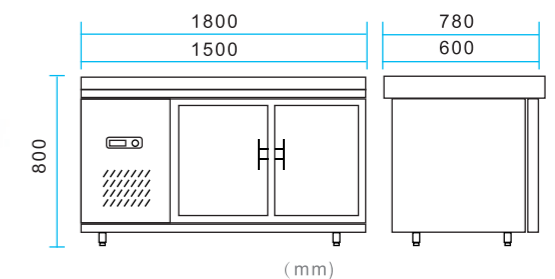

#### ◀ TC0.25L2GB / TC0.4L2GB

Model	<b>TC0.25L2GB</b>	<b>TC0.4L2GB</b>
Dimension(mm)	1500x600x800	1800x780x800
Voltage Source	220V/50Hz	220V/50Hz
Input Power	200W	200W
Temperature Rang	0~10°C	0~10°C
Cooling Way	Static	Static
Refrigerant	R134a	R134a



# 04

## KITCHEN CABINET

EXPERIENCE LEADING TECHNOLOGY, FOCUS ON LIFE

- 1.High quality casters
- 2.Humanized design
- 3.Can place standard Giv pans
- 4.Internal round sink type design
- 5.High density polyurethane foam
- 6.High quality stainless steel body
- 7.Precision temperature controller
- 8.High quality bearing shelf

Air cooled kitchen cabinet



◀ KD0.5F

Model	<b>KD0.5F</b>
Dimension(mm)	640x760x2000
Voltage Source	220V/50Hz
Input Power	420W
Temperature Rang	-6~-18°C
Cooling Way	Air Cooling
Refrigerant	R134a

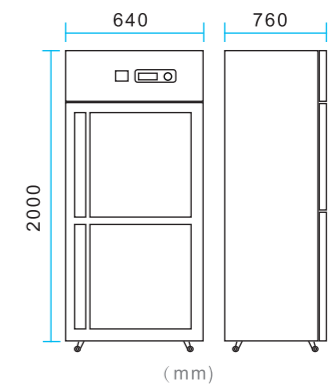

Air cooled kitchen cabinet



◀ KCD1.0L4F

Model	<b>KCD1.0L4F</b>
Dimension(mm)	1210x760x2000
Voltage Source	220V/50Hz
Input Power	420W
Temperature Rang	-6~-18°C
Cooling Way	Air Cooling
Refrigerant	R134a

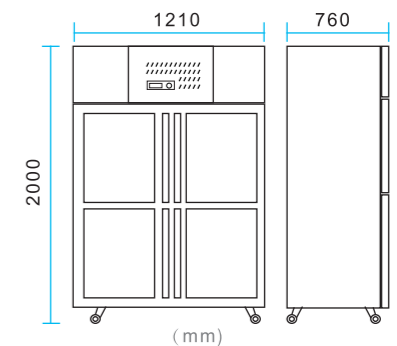

## KITCHEN CABINET

In pieces stereo enjoy fresh experience Luxury and beauty light box and cabinet lighting design, Microcomputer temperature control, Simple and fluent line, Pieces of atmospheric SanKaiMen show appearance In pieces and transparent glass window design, Pieces of ice cool and fresh feeling, In pieces the air-filled solid circulation, refrigeration and no dead Angle, In pieces to create perfect stable cold storage space; Your life acme, pieces make you relaxed.



**XING LING**

Guangzhou XingLing Kitchen Refrigeration Equipment Co., Ltd is one of emerging technology company, Its core is manufacturing technology and refrigeration equipment. We offer not only high-quality refrigeration solutions to customers, but also the most energy-efficient economic environment-friendly refrigeration products (display cabinets, supermarket display cabinets, drug cooler display cabinets, kitchen freezers, cake showcase and so on) to the world. We make our customers to be more competitive with our professional experience. Our equipments are designed with streamlined lines appearance which is nice, elegant and practical. And user-friendly design function makes our products to achieve the perfect fusion from inside to outside. We strictly according to ISO9001 international quality management system, and fused the advanced technology and top technology to provide the accurate recommendations and the most innovative design solutions for customers.

## PROFESSIONAL DESIGN

- 1.Exterior design simple fashion generous, luxury stule.
- 2.Fully open refrigeraton display space, more convenient access to food.
- 3.The ventilation system in the cabinet is perfect and the air is fresh and clean.
- 4.Shelf height can be freely adjusted, flexible planning space.
- 5.LED lighting system.
6. built in high quality plastic shelf.
7. high color steel design.
8. stereo advertising lamp box.

# 04

## KITCHEN CABINET

EXPERIENCE LEADING TECHONLOGY,FOCUS ON LIFE

- 1.High quality casters
- 2.Humanized design
- 3.Can place standard Giv pans
- 4.Internal round sink type design
- 5.High density polyurethane foam
- 6.High quality stainless steel body
- 7.Precision temperature controller
- 8.High quality bearing shelf

### Air cooled kitchen cabinet



#### ◀ KCD1.6L6F

Model	<b>KCD1.6L6F</b>
Dimension(mm)	1810x760x2000
Voltage Source	220V/50Hz
Input Power	750W
Temperature Rang	-6~-12 / 0~10°C
Cooling Way	Air Cooling
Refrigerant	R134a

**XING LING**  
**FREEZER**

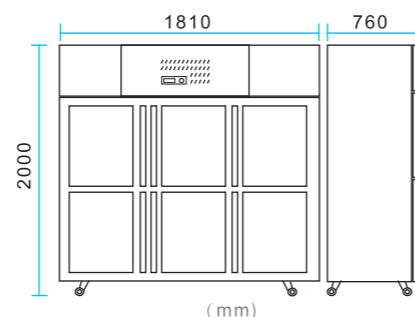

### Four door cupboard



#### ◀ KCD1.0L4GC

Model	<b>KCD1.0L4GC</b>
Dimension(mm)	1210x760x1900
Voltage Source	220V/50Hz
Input Power	390W
Temperature Rang	-6~-12 / 0~10°C
Cooling Way	Static
Refrigerant	R134a

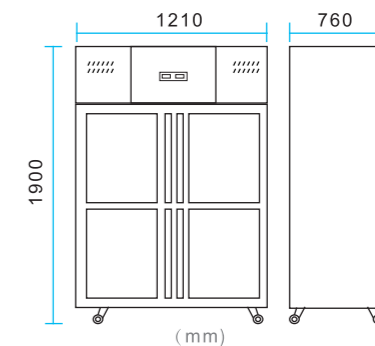

### Air cooled kitchen cabinet

#### ◎ DELICACY

Exquisite quality, taste fresh life.

#### ◎ POTENCY

Awaken potential of refrigeration, dance out of the new Xing ling.



#### ◀ TC0.4L2F

Model	<b>TC0.4L2F</b>
Dimension(mm)	1800x780x800
Voltage Source	220V/50Hz
Input Power	260W
Temperature Rang	0~10°C
Cooling Way	Air Cooling
Refrigerant	R134a

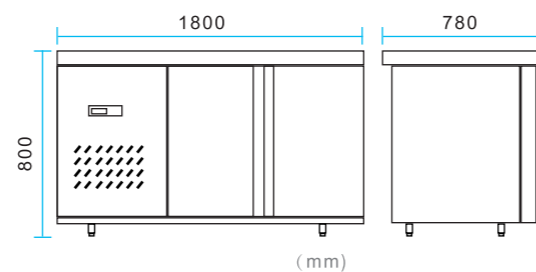

### Six door cupboard



#### ◀ KCD1.6L6GC

Model	<b>KCD1.6L6GC</b>
Dimension(mm)	1810x760x1900
Voltage Source	220V/50Hz
Input Power	390W
Temperature Rang	-6~-12 / 0~10°C
Cooling Way	Static
Refrigerant	R134a

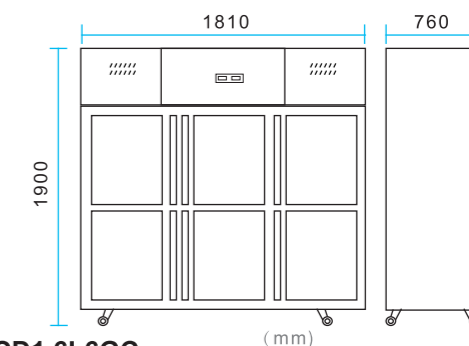



# KITCHEN CABINET

In pieces stereo enjoy fresh experience Luxury and beauty light box and cabinet lighting design, Microcomputer temperature control, Simple and fluent line, Pieces of atmospheric SanKaiMen show appearance In pieces and transparent glass window design; Pieces of ice cool and fresh feeling, In pieces the air-filled solid circulation, refrigeration and no dead Angle, In pieces to create perfect stable cold storage space; Your life acme, pieces make you relaxed.



XING LING



Guangzhou XingLing Kitchen Refrigeration Equipment Co.,Ltd is one of emerging technology company ,Its core is manufacturing technology and refrigeration equipment. We offer not only high-quality refrigeration solutions to customers, but also the most energy-efficient economic environment-friendly refrigeration products (display cabinets, supermarket display cabinets, drug cooler display cabinets, kitchen freezers ,cake showcase and so on) to the world. We make our customers to be more competitive with our professional experience. Our equipments are designed with streamlined lines appearance which is nice, elegant and practical. And user-friendly design function makes our products to achieve the perfect fusion from inside to outside. We strictly according to ISO9001 international quality management system, and fused the advanced technology and top technology to provide the accurate recommendations and the most innovative design solutions for customers.

# 04

## KITCHEN CABINET

EXPERIENCE LEADING TECHNOLOGY, FOCUS ON LIFE

1. High quality casters
2. Humanized design
3. Can place standard Giv pans
4. Internal round sink type design
5. High density polyurethane foam
6. High quality stainless steel body
7. Precision temperature controller
8. High quality bearing shelf

### Air cooled drawer cabinet

#### QUALITY ASSURANCE

For xingling, quality is satisfying customers. We continuously test and complete our products and process flow. We use leading technology facilities, advanced equipment and conscientious attitude to implement the producing and products quality management system. And achieving a comprehensive excellence xingling.

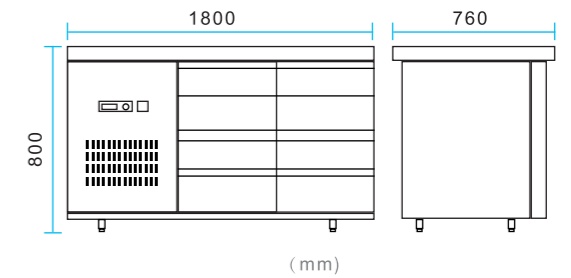

#### TC0.4CT

Model	TC0.4CT
Dimension(mm)	1800x760x800
Voltage Source	220V/50Hz
Input Power	180W
Temperature Rang	-5~5°C
Cooling Way	Air Cooling
Refrigerant	R134a

### Deluxe workbench

#### PROFESSIONAL DESIGN

Our equipments are designed with streamlined lines appearance which is nice, elegant and practical. And user-friendly design function makes our products to achieve the perfect fusion from inside to outside. We strictly according to ISO9001 international quality management system, and fused the advanced technology and top technology to provide the accurate recommendations and the most innovative design solutions for customers.

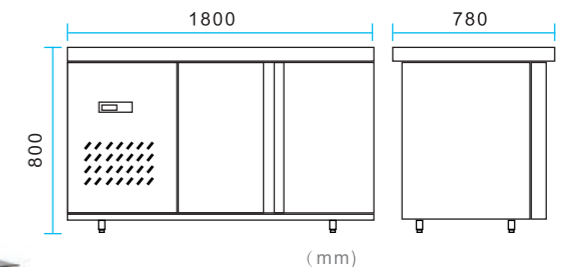

#### TC0.4L2GC

Model	TC0.4L2GC
Dimension(mm)	1800x780x800
Voltage Source	220V/50Hz
Input Power	180W
Temperature Rang	0~10°C
Cooling Way	Static
Refrigerant	R134a



## HIGH QUALITY STAINLESS STEEL BODY

- 1.Exterior design simple fashion generous, luxury stule.
- 2.Fully open refrigeraton display space, more convenient access to food.
- 3.The ventilation system in the cabinet is perfect and the air is fresh and clean.
- 4.Shelf height can be freely adjusted, flexible planning space.
- 5.LED lighting system.
6. built in high quality plastic shelf.
7. high color steel design.
8. stereo advertising lamp box.

# 04

## KITCHEN CABINET

EXPERIENCE LEADING TECHONLOGY,FOCUS ON LIFE

- 1.High quality casters
- 2.Humanized design
- 3.Can place standard Giv pans
- 4.Internal round sink type design
- 5.High density polyurethane foam
- 6.High quality stainless steel body
- 7.Precision temperature controller
- 8.High quality bearing shelf

### Water bar

#### ST-1800 / ST-2000

Model	ST-1800	ST-2000
Dimension(mm)	1800x760x950	2000x760x950
Voltage Source	220V/50Hz	220V/50Hz
Input Power	260W	260W
Temperature Rang	0~10°C	0~10°C
Cooling Way	Static	Static
Refrigerant	R134a	R134a

◎ **DELICACY**  
Exquisite quality, taste fresh life.

◎ **FRESH**  
See the fresh,xing ling will Interpret the price for you.

◎ **POTENCY**  
Awaken potential of refrigeration, dance out of the new Xing ling.

◎ **IMAGINE**  
Through the brush of imagination, The glory of the dye xing ling and pentium.



### INDUSTRY REPUTATION BEYOND 86% PEERS

More than ten, the quality of continuous pursuit, from the details of the departure, the completion of self optimization, the quality of persistence, is "Xing Ling" commitment to customers.

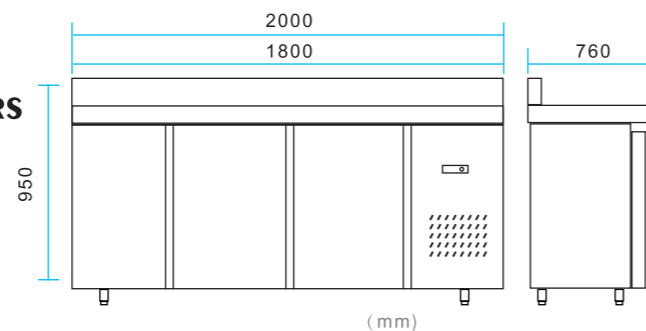

### Blast freezer

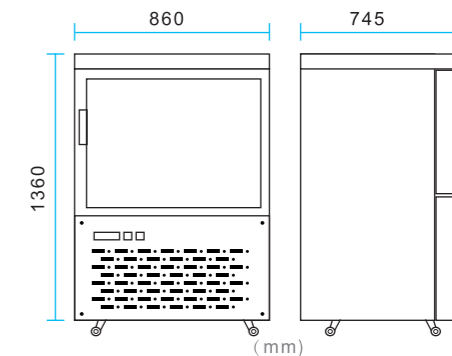

#### SDG-860

Model	SDG-860
Dimension(mm)	860x745x1360
Voltage Source	220V/50Hz
Input Power	1200W
Temperature Rang	-30°C
Cooling Way	Air Cooling
Refrigerant	R404a

### Water tank

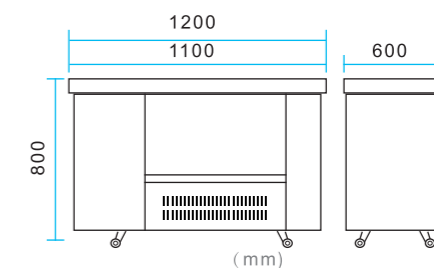

#### W-160 / W-200

Model	W-160	W-200
Dimension(mm)	1100x600x800	1200x600x800
Voltage Source	220V/50Hz	220V/50Hz
Input Power	180W	180W
Temperature Rang	5~10°C	5~10°C
Cooling Way	Water Cooling	Water Cooling
Refrigerant	R134a	R134a

# KITCHEN CABINET

In pieces stereo enjoy fresh experience Luxury and beauty light box and cabinet lighting design, Microcomputer temperature control, Simple and fluent line, Pieces of atmospheric SanKaiMen show appearance In pieces and transparent glass window design; Pieces of ice cool and fresh feeling, In pieces the air-filled solid circulation, refrigeration and no dead Angle, In pieces to create perfect stable cold storage space; Your life acme, pieces make you relaxed.



XING LING



# 04

## KITCHEN CABINET

EXPERIENCE LEADING TECHONLOGY, FOCUS ON LIFE

1. High quality casters
2. Humanized design
3. Can place standard Giv pans
4. Internal round sink type design
5. High density polyurethane foam
6. High quality stainless steel body
7. Precision temperature controller
8. High quality bearing shelf

Blue cabinet

### TC-1200 / TC0.25L2 / TC0.4L2

Model	TC-1200	TC0.25L2	TC0.25L2	TC0.4L2
Dimension(mm)	1200x600x800	1500x600x800	1500x780x800	1800x780x800
Voltage Source	220V/50Hz	220V/50Hz	220V/50Hz	220V/50Hz
Input Power	160W	160W	160W	160W
Temperature Rang	0~10°C	0~10°C	0~10°C	0~10°C
Cooling Way	Static	Static	Static	Static
Refrigerant	R134a	R134a	R134a	R134a



XING LING

WORK CABINET

### QUALITY ASSURANCE

For xingling, quality is satisfying customers. We continuously test and complete our products and process flow. We use leading technology facilities, advanced equipment and conscientious attitude to implement the producing and products quality management system. And achieving a comprehensive excellence xingling.

Guangzhou XingLing Kitchen Refrigeration Equipment Co., Ltd is one of emerging technology company, Its core is manufacturing technology and refrigeration equipment. We offer not only high-quality refrigeration solutions to customers, but also the most energy-efficient economic environment-friendly refrigeration products (display cabinets, supermarket display cabinets, drug cooler display cabinets, kitchen freezers, cake showcase and so on) to the world. We make our customers to be more competitive with our professional experience. Our equipments are designed with streamlined lines appearance which is nice, elegant and practical. And user-friendly design makes our products to achieve the perfect fusion from inside to outside. We strictly according to ISO9001 international quality management system, and fused the advanced technology and top technology to provide the accurate recommendations and the most innovative design solutions for customers.

# KITCHEN CABINET

In pieces stereo enjoy fresh experience Luxury and beauty light box and cabinet lighting design, Microcomputer temperature control, Simple and fluent line, Pieces of atmospheric SanKaiMen show appearance In pieces and transparent glass window design; Pieces of ice cool and fresh feeling, In pieces the air-filled solid circulation, refrigeration and no dead Angle, In pieces to create perfect stable cold storage space; Your life acme, pieces make you relaxed.



XING LING



Guangzhou XingLing Kitchen Refrigeration Equipment Co.,Ltd is one of emerging technology company ,Its core is manufacturing technology and refrigeration equipment. We offer not only high-quality refrigeration solutions to customers, but also the most energy-efficient economic environment-friendly refrigeration products (display cabinets, supermarket display cabinets, drug cooler display cabinets, kitchen freezers ,cake showcase and so on) to the world. We make our customers to be more competitive with our professional experience. Our equipments are designed with streamlined lines appearance which is nice, elegant and practical. And user-friendly design function makes our products to achieve the perfect fusion from inside to outside. We strictly according to ISO9001 international quality management system, and fused the advanced technology and top technology to provide the accurate recommendations and the most innovative design solutions for customers.

# 04

## KITCHEN CABINET

EXPERIENCE LEADING TECHNOLOGY, FOCUS ON LIFE

1. Full display glass window
2. Front glass Defrost design
3. Curved glass design
4. Automatic defrost
5. Fan cooling cycle refrigeration technology
6. LED lighting
7. Microcomputer control
8. Precision temperature controller
9. Universal casters.
10. High efficiency heat exchanger
11. brand compressor
12. High efficiency evaporator

### Pizza counter

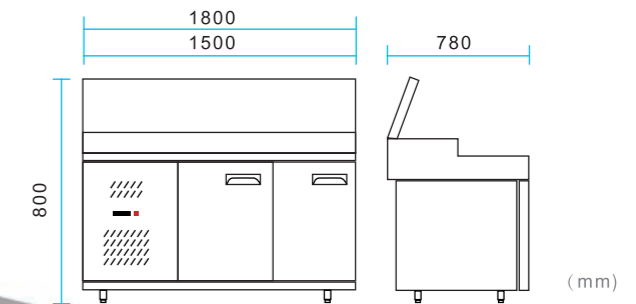

PSG-1500A / PSG-1800A

Model	PSG-1500A	PSG-1800A
Dimension(mm)	1500x780x800	1800x780x800
Voltage Source	220V/50Hz	220V/50Hz
Input Power	280W	280W
Temperature Rang	0~10°C	0~10°C
Cooling Way	Air Cooling	Air Cooling
Refrigerant	R134a	R134a
Escription	Two Door	Two Door

### Salad bar

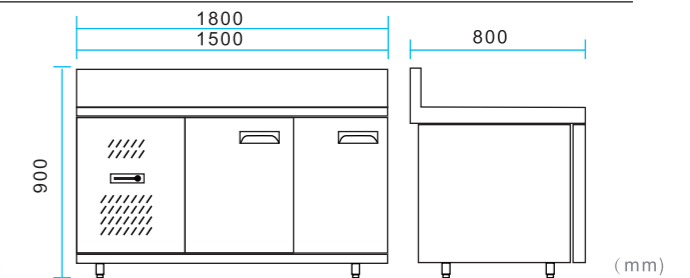

PSG-1500 / PSG-1800

Model	PSG-1500	PSG-1800
Dimension(mm)	1500x800x900	1800x800x900
Voltage Source	220V/50Hz	220V/50Hz
Input Power	260W	260W
Temperature Rang	0~10°C	0~10°C
Cooling Way	Static	Static
Refrigerant	R134a	R134a
Escription	Two Door	Two Door



### PROFESSIONAL DESIGN

- 1.Exterior design simple fashion generous, luxury stule.
- 2.Fully open refrigeraton display space, more convenient access to food.
- 3.The ventilation system in the cabinet is perfect and the air is fresh and clean.
- 4.Shelf height can be freely adjusted, flexible planning space.
- 5.LED lighting system.
6. built in high quality plastic shelf.
7. high color steel design.
8. stereo advertising lamp box.

# 04

## FREEZER SERIES

EXPERIENCE LEADING TECHONLOGY,FOCUS ON LIFE

- 1.Full display glass window
- 2.Front glass Defrost design
- 3.Curved glass design
- 4.Automatic defrost
- 5.Fan cooling cycle refrigeration technology
- 6.LED lighting
- 7.Microcomputer control
- 8.Precision temperature controller
- 9.Universal casters.
- 10.High efficiency heat exchanger
- 11.brand compressor
- 12.High efficiency evaporator

Salad bar

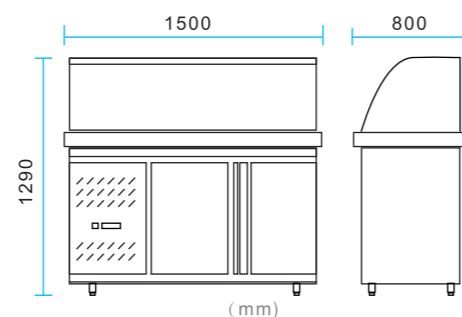

### TC-1500

Model	<b>TC-1500</b>
Dimension(mm)	1500x800x1290
Voltage Source	220V/50Hz
Input Power	160W
Temperature Rang	0~10°C
Cooling Way	Static
Refrigerant	R134a

Bar cabinet

### TH-1200

Model	<b>TH-1200</b>
Dimension(mm)	1200x600x1100
Voltage Source	220V/50Hz
Input Power	180W
Temperature Rang	0~10°C
Cooling Way	Static
Refrigerant	R134a

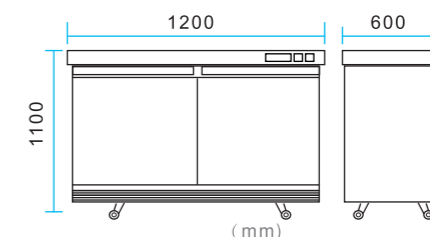

### DELICACY

Exquisite quality, taste fresh life.

### FRESH

See the fresh,xing ling will Interpret the price for you.

### POTENCY

Awaken potential of refrigeration, dance out of the new Xing ling.

Double pizza table



### PROFESSIONAL DESIGN

Our equipments are designed with streamlined lines appearance which is nice,elegant and practical.And user-friendly design function makes our products to achieve the perfect fusion from inside to outside.We strictly according to ISO9001 international quality management system, and fused the advanced technology and top technology to provide the accurate recommendations and the most innovative design solutions for customers.

### TC-1350

Model	<b>TC-1350</b>
Dimension(mm)	1350x600x1400
Voltage Source	220V/50Hz
Input Power	320W
Temperature Rang	0~10°C
Cooling Way	Static
Refrigerant	R134a



### ENTERPRISE CATALOG//

XingLing has a variety of advanced processing and production equipment, a variety of professional staff at all levels. XingLing today for the development of the enterprise to meet customer needs, in order to "continuous innovation, customer satisfaction, rapid improvement, full participation" as the basic quality; with exquisite production technology, strict service spirit and strict testing procedures, make high quality products are pouring out, effectively to meet the different needs of customers.