

Make good robots for clients.

CRP

CRP AUTOMATION



CRP ROBOTICS



Please watch us on YouTube Channel:
<https://www.youtube.com/channel/UC6DXCe07c8aaT6W-v94F25w>
You can also watch us on YouTube by scanning this QR Code.

Contact us:
Email: sharonxiao@crprobotglobal.com
Mobile/whatsapp/wehcat: +86 13438150687
International Website: www.crprobotglobal.com
Chinese Website: www.crrobot.com
Address: No. 8, Hangtian Road, Chenghua District, Chengdu, China
CRP TECH CO., LTD

Professionals
Industrial robot control system

CRP
About Us



CRP Robotics is a high-tech robot manufacturer providing Automation Solutions and Support to our customers. Our products are used in industrial automation such as welding, painting, handling, palletizing and polishing. And after years of development, our core technology has been widely used in the field of industrial robots in China. We have 90% of the robot controller market share in China, offering professional, timely service and complete robot application solutions. Our robot system is highly stable and matured. We're one of the earliest team who manufactures industrial robots.

Our industrial robot body and controller are developed by our company with independent intellectual property rights. The advantages are: highly cost-effective, well-knit compact structure, flexibility, high reliability, high speed, high precision, high expansibility, easy operation, easy maintenance. The motion of each joint of the robot is realized by a servo motor and a high precision and rigidity reducer with the integrated drive controller technology.



Production Demonstration

Robot Controller

Years of cultivation.
Tens of thousands of application.
More than 50% market share.



Special integrated drive-controller for robot

We created the high-performance integrated drive-controller by our professional team.



Factory Test

13 fully automated tests ensure consistency of the batch product.



传感器采集数据	测试值	范围下限	范围上限
传感器1	0.01	-0.08	0.08
传感器2	-0.01	-0.08	0.08
传感器3	0.02	-0.08	0.08

负载率采集数据	1轴	2轴	3轴	4轴	5轴
峰值	55	60	54	57	
平均值	51	51	51	51	
标准差	180	180			

Intelligent Sensor

Expanding the depth and breadth of the industry
Simple and easy to use
Comprehensive and full-featured



Mechanical Design

Strictly and elaborately designed by our precise transmission design team.

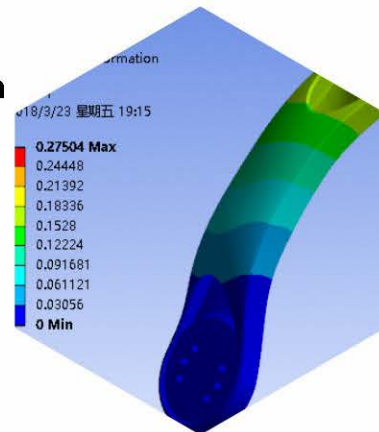

Component Inspection

The strict inspection of components ensures accuracy and quality.

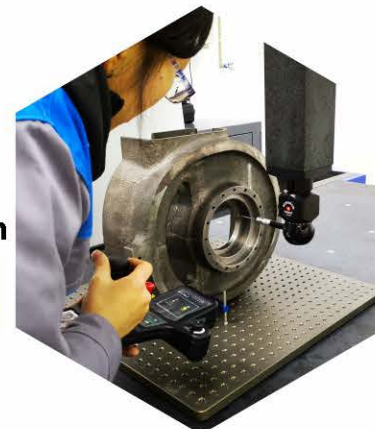

Type Test

16 major items test and 64 minor items test ensure reliability and quality.



Production Process

Strict production process, consistent and efficient.

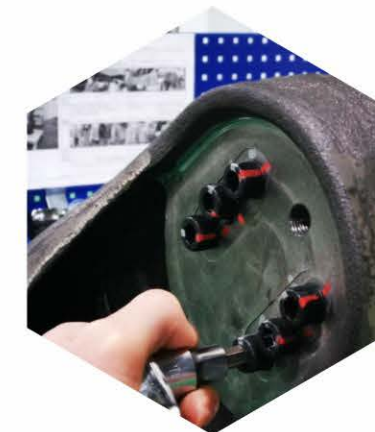

G4 Industrial Robot Electrical Cabinet



Three-phase three-wire power filter



Three-phase dry-type servo isolation transformer



Double switching power supply

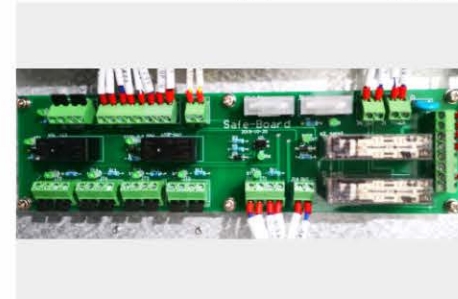

Built-in safety circuit

Cabinet Technical Index

Teaching pendant	8-inch TFT-LCD, button + touch screen, mode selection switch, safety switch, emergency stop button
User memory	200M
Axis quantity that can be contro	6 + 2 axes, 6 robot body axes + 2 external axes
Interface	Digital I/O interface, EtherCAT, 22 input / output(expandable COM)
	4-way 0~10V analog output, 12-bit accuracy(expandable COM)
	Two-way encoder signal interface(position tracking)
	Ethernet communication interface Double USB interface
Operation mode	Teaching, reproduction, remote
Moving function	Point-to-point, straight line, circle
Command system	Motion, logic, process, operation
Coordinate system	Joint coordinates, rectangular coordinates, user coordinates, tool coordinates, and base coordinates
Abnormal detection function	Abnormal stop, abnormal servo, abnormal user coordinates, abnormal tool coordinates, safety maintenance, abnormal arc, etc.
Robot safety	External emergency stop, anti-collision and safety bolt interface; MC safety circuit, servo soften, etc.
Reserved specific interface	arc welding interface, workstation interface
Software package	With options of welding, handling, palletizing, painting, and spraying applications
Others	Built-in PLC, regenerative braking, encoder interface(supporting synchronous belt), arc tracking and accessories(optional), vision software(optional), laser tracking software(optional), etc.
Connecting cable	3m
Power supply	Three phase 380V AC 50-60HZ
Dimension	550mm×785mm×410mm
Weight	56KG

Cabinet Dimensional Drawing

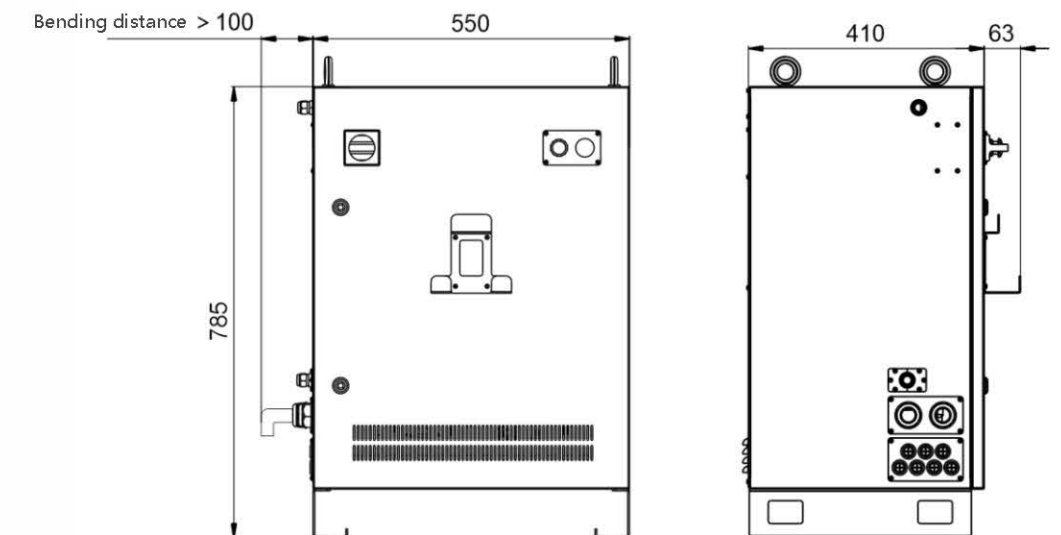

CRP-RH14-10

Industrial Robot Handling Application



Functional Features

- ★ Payload is 10kg. The arm span is 1.4 meters. It can be installed on the ground or upside down flexibly.
- ★ With large working space and fast running speed, it is suitable for welding, spraying, loading and unloading, handling, sorting, assembling and other applications.
- ★ The safety emergency stop board is independent of the controller, and the safety relay circuit is adopted to provide double circuit emergency stop to ensure the reliability of emergency stop.
- ★ The robot body cables are made of special cables for flexible robots. Built-in three-phase transformer, 380V and 200V isolation, more stable power supply. (Power supply requirements can be customized for different countries.)
- ★ Built-in three phase filter can effectively improve the performance of EMC and EMI.
- ★ The robot body is with dual-circuit gas pipe and meets welding and handling requirements

Installation Interface Diagram

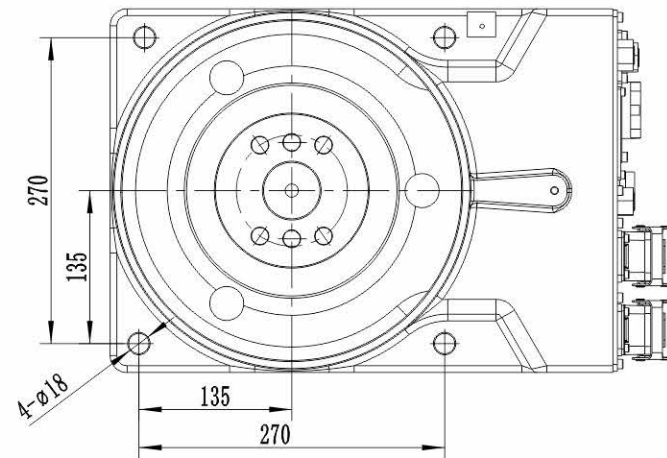

Installation Dimension of Base

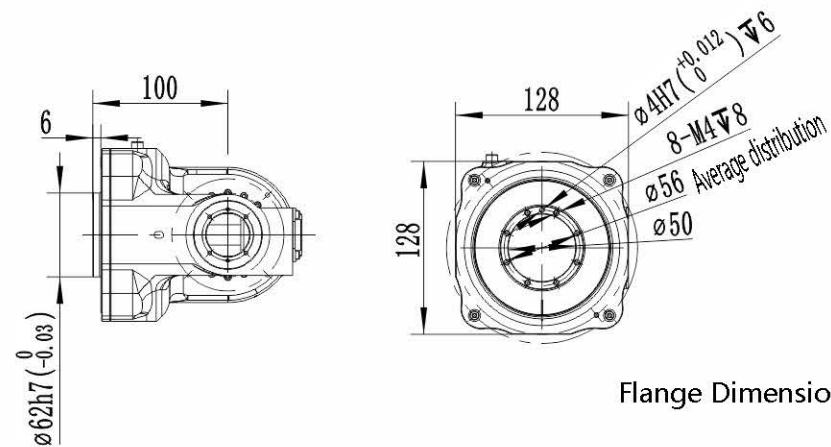

Flange Dimensions

Motion Range Diagram

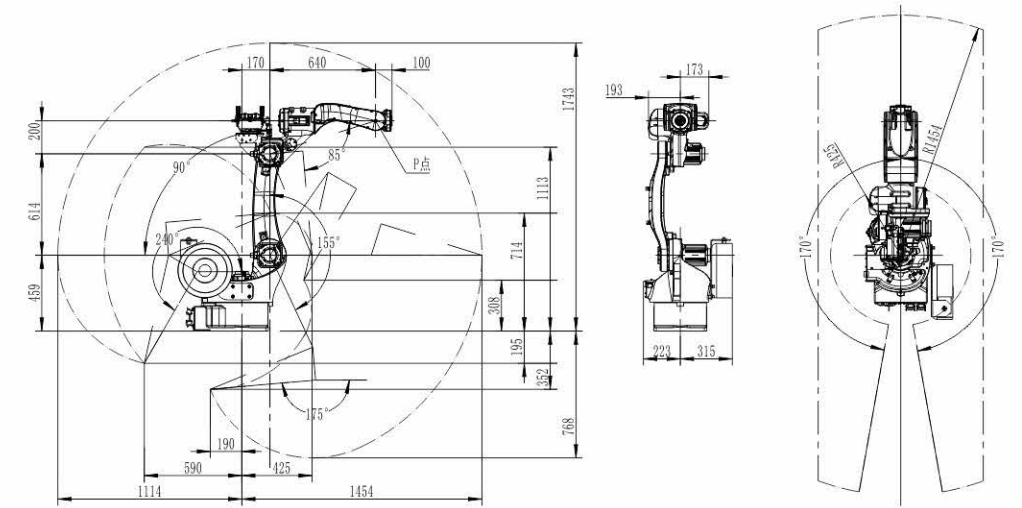

Robot Body Technical Parameters

Model	CRP-RH14-10	
Arm form	Vertical multiple joints	
Degree of freedom	6 axis	
Maximum payload	10KG	
Maximum travel	axis 1	-167° - 167°
	axis 2	0° - 175°
	axis 3	-80° - 150°
	axis 4	-190° - 190°
	axis 5	-105° - 130°
	axis 6	-210° - 210°
Maximum speed	axis 1	169°/S
	axis 2	169°/S
	axis 3	169°/S
	axis 4	280°/S
	axis 5	240°/S
	axis 6	520°/S
Allowable torque	axis 4	10N.m
	axis 5	10N.m
	axis 6	3N.m
Allowable moment of inertia	axis 4	0.25kg.m ²
	axis 5	0.25kg.m ²
	axis 6	0.05kg.m ²
Repeated positioning accuracy	±0.08mm、	
Maximum reaching distance	1440mm	
Robot body weight	170KG	
Installation mode	Ground or upside down mounting	
Installation environment	ambient temperature	0~45°C
	relative humidity	20~80% (No condensation)
	vibration	Under 0.5 G
Others	Robot installation must be away from: Flammable or corrosive liquids or gases, electrical sources of interference	
IP level	IP56	
Advantage features	Compact structure, high speed, high precision, high expansibility and easy operation	
Application	cutting, assembly, handling, marking, grinding	

CRP-RH18-20

Industrial Robot Handling Application



Functional Features

- ★ With compact design 20kg payload and about 1.8 meters arm span, it can be installed on the ground or upside down flexibly.
- ★ With large working space and fast running speed, it is suitable for welding, spraying, loading and unloading, handling, sorting, assembling and other applications.
- ★ The safety emergency stop board is independent of the controller, and the safety relay circuit is adopted to provide double circuit emergency stop to ensure the reliability of emergency stop.
- ★ The robot body cables are made of special cables for highly flexible robots.
- ★ Built-in three-phase transformer, 380V and 200V isolation, more stable power supply.
- ★ Power supply requirements can be customized for different countries. Built-in three-phase filter can effectively improve the performance of EMC and EMI.
- ★ The robot body is with dual-circuit gas pipe and meets welding and handling requirements.

Installation Interface Diagram

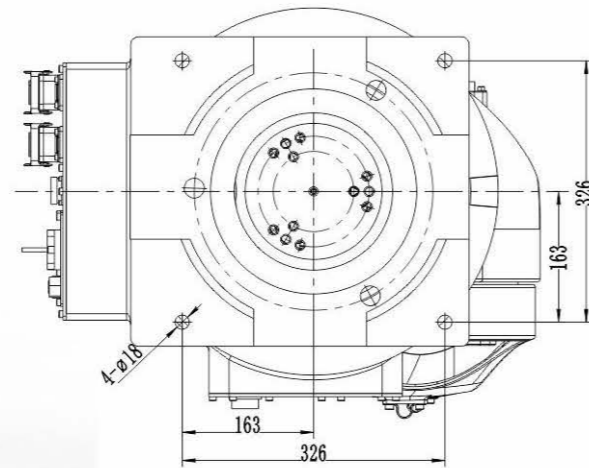

Installation Dimension of Base

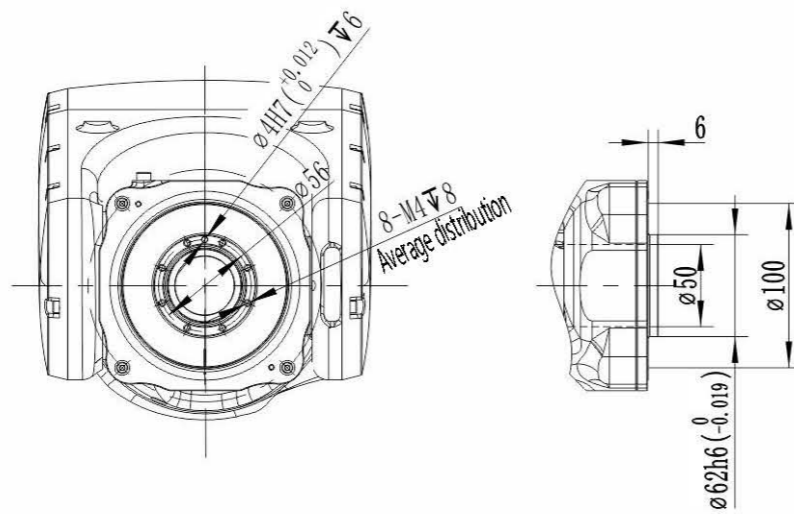

Flange Dimensions

Motion Range Diagram

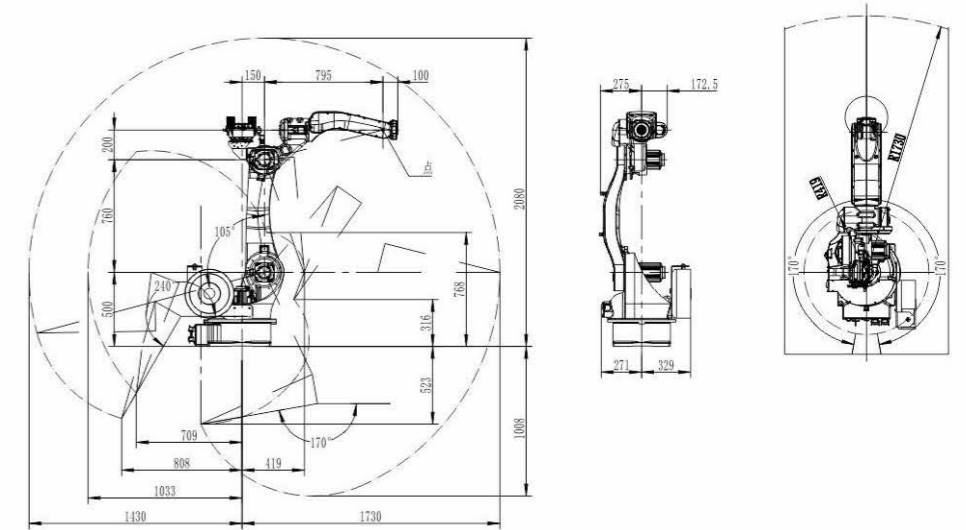

Robot Body Technical Parameters

Model	CRP-RH18-20	
Arm form	Vertical multiple joints	
Degree of freedom	6 axis	
Maximum payload	20KG	
Maximum travel	axis 1	-167° - 167°
	axis 2	0° - 175°
	axis 3	-80° - 150°
	axis 4	-190° - 190°
	axis 5	-105° - 130°
	axis 6	-210° - 210°
Maximum speed	axis 1	159°/S
	axis 2	159°/S
	axis 3	169°/S
	axis 4	280°/S
	axis 5	240°/S
	axis 6	483°/S
Allowable torque	axis 4	48N.m
	axis 5	48N.m
	axis 6	28N.m
Allowable moment of inertia	axis 4	1.8kg.m ²
	axis 5	1.8kg.m ²
	axis 6	0.8kg.m ²
Repeated positioning accuracy	±0.08mm、	
Maximum reaching distance	1720mm	
Robot body weight	285KG	
Installation mode	Ground or upside down mounting	
Installation environment	ambient temperature	0~45°C
	relative humidity	20~80% (No condensation)
	vibration	Under 0.5 G
Others	Robot installation must be away from: Flammable or corrosive liquids or gases, electrical sources of interference	
IP level	IP56	
Advantage features	Compact structure, high speed, high precision, high expansibility and easy operation	
Application	Cutting, assembly, handling, marking, grinding	

CRP-RH20-10

Industrial Robot Handling Application



Functional Features

- ★With compact design 10kg payload and about 2.0 meters arm span, it can be installed on the ground or upside down flexibly.
- ★With large working space and fast running speed, it is suitable for welding, spraying, loading and unloading, handling, sorting, assembling and other applications.
- ★The safety emergency stop board is independent of the controller, and the safety relay circuit is adopted to provide double circuit emergency stop to ensure the reliability of emergency stop.
- ★The robot body cables are made of special cables for highly flexible robots.
- ★Built-in three-phase transformer, 380V and 200V isolation, more stable power supply.
- ★Power supply requirements can be customized for different countries. Built-in three-phase filter can effectively improve the performance of EMC and EMI.
- ★The robot body is with dual-circuit gas pipe and meets welding and handling requirements

Installation Interface Diagram

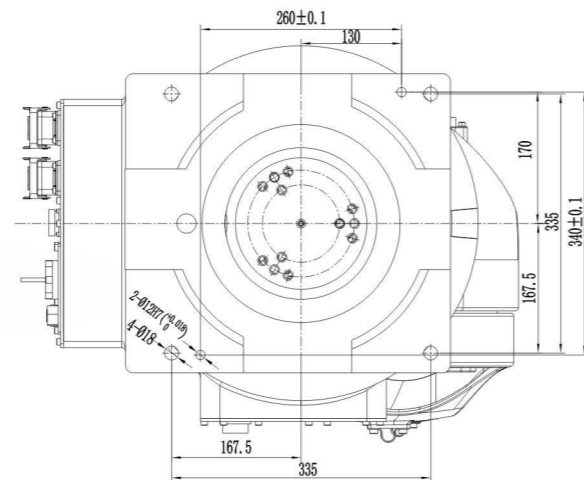

Installation Dimension of Base

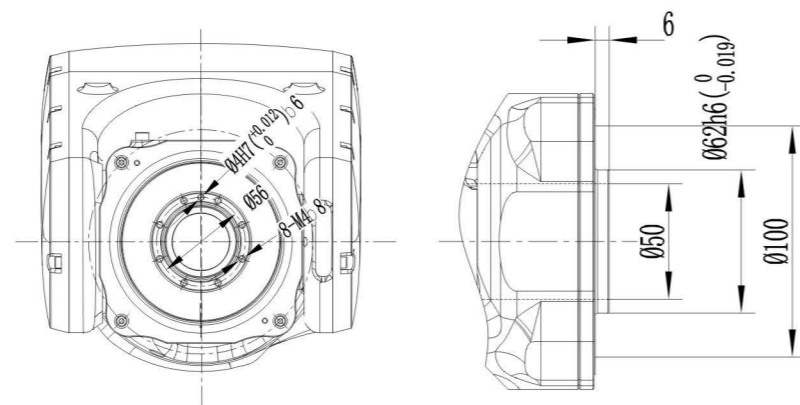

Flange Dimensions

Motion Range Diagram

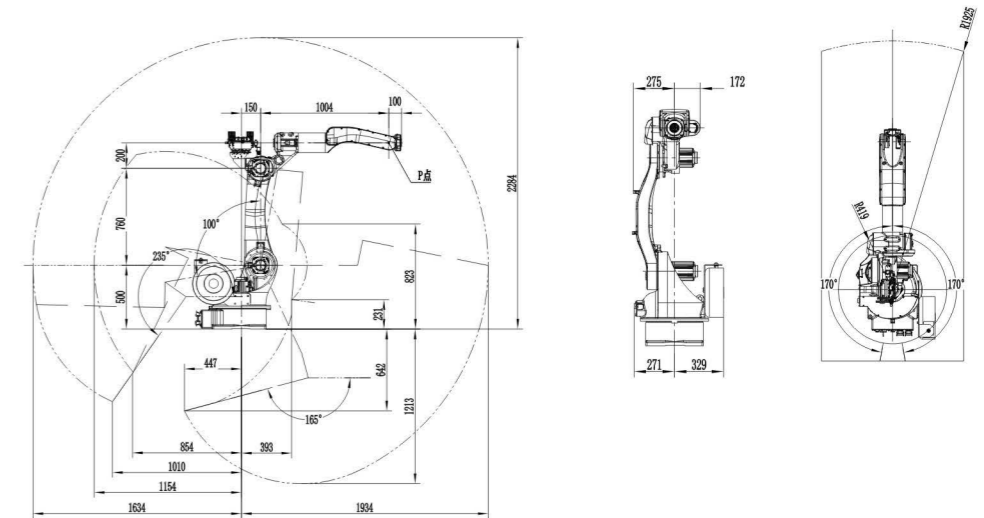

Robot Body Technical Parameters

Model	CRP-RH20-10	
Arm form	Vertical multiple joints	
Degree of freedom	6 axis	
Maximum payload	10KG	
Maximum travel	axis 1	Ground/upside down mounting -167°~167°, wall mounting -30°~30°
	axis 2	0° - 175°
	axis 3	-80° - 150°
	axis 4	-190° - 190°
	axis 5	-105° - 130°
	axis 6	-210° - 210°
Maximum speed	axis 1	159°/S
	axis 2	159°/S
	axis 3	169°/S
	axis 4	280°/S
	axis 5	240°/S
	axis 6	483°/S
Allowable torque	axis 4	24N.m
	axis 5	24N.m
	axis 6	14N.m
Allowable moment of inertia	axis 4	1.4kg.m ²
	axis 5	1.4kg.m ²
	axis 6	0.5kg.m ²
Repeated positioning accuracy	±0.08mm、	
Maximum reaching distance	1920mm	
Robot body weight	288KG	
Installation mode	Ground or upside down mounting or wall mouting	
Installation environment	ambient temperature	0~45°C
	relative humidity	20~80%l(No condensation)
	vibration	Under 0.5 G
	Others	Robot installation must be away from: Flammable or corrosive liquids or gases, electrical sources of interference
IP level	:Body IP54 , wrist IP	
Advantage features	Compact structure, high speed, high precision, high expansibility and easy operation	
Application	Welding, cutting, assembly, handling, marking, grinding	

CRP-RA09-06

Industrial Robot Handling Application



Functional Features

- ★ Well-knit design makes the robot body more slender than other same level product, so it is more flexible even in a small space, also keep a very low rate of collision with surrounding devices.
- ★ Maximum reach 915 mm.
- ★ Lighter structure design than other same level product, so it is easy to install inside a system or to mount upside-down
- ★ High rigidity arm and top level servo control technology guarantee the smoothness and stability while the movement.
- ★ Rated payload 6 kg, easily applied in multi application.
- ★ Built-in cable, no more catheter and cable twisting on the arm. Leak-proof structure, can be applied in dust and oil-mist environment.

Installation Interface Diagram

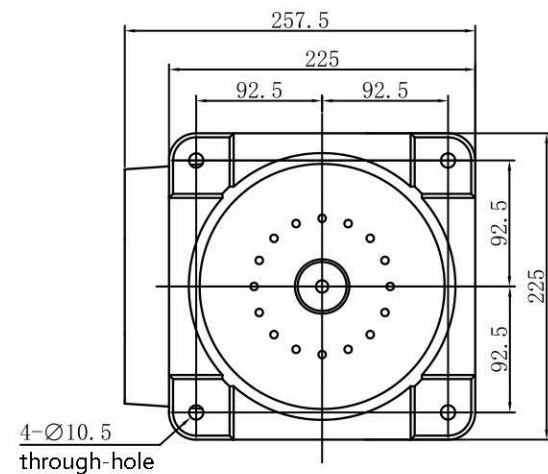

Installation Dimension of Base

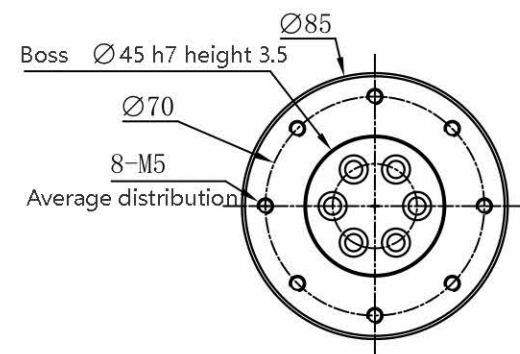

Flange Dimensions

Motion Range Diagram

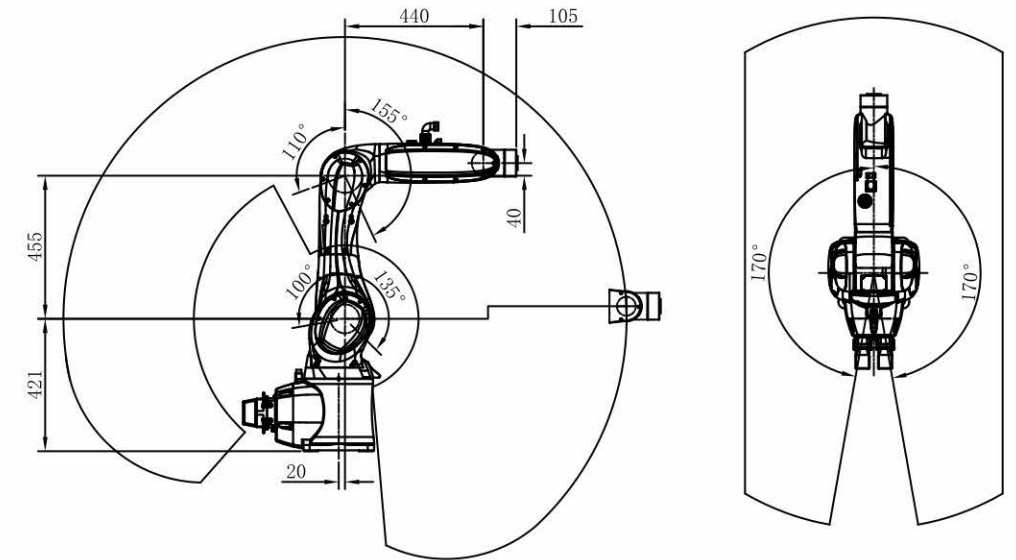

Robot Body Technical Parameters

Model	CRP-RA09-06	
Arm form	Vertical multiple joints	
Degree of freedom	6 axis	
Maximum payload	6KG	
Maximum travel	axis 1	-170° - 170°
	axis 2	-45° - 190°
	axis 3	-155° - 110°
	axis 4	-170° - 170°
	axis 5	-120° - 120°
	axis 6	-360° - 360°
Maximum speed	axis 1	337.5°/S
	axis 2	270°/S
	axis 3	375°/S
	axis 4	300°/S
	axis 5	375°/S
	axis 6	468°/S
Repeated positioning accuracy	±0.03m	
Maximum reaching distance	915mm	
Robot body weight	60KG	
Installation mode	Ground or upside down mounting	
Installation environment	ambient temperature	0~45°C
	relative humidity	20~80% (No condensation)
	vibration	Under 0.5 G
	Others	Robot installation must be away from: Flammable or corrosive liquids or gases, electrical sources of interference
IP level	IP65	
Advantage features	Compact structure, high speed, high precision, high expansibility and easy operation	
Application	Cutting, assembly, handling, marking, grinding	

CRP-RH18-20-W

Industrial Robot Welding Application



Functional Features

- ★ With compact design 20kg payload and about 1.8 meters arm span, it can be installed on the ground or upside down flexibly.
- ★ With large working space and fast running speed, it is suitable for welding, spraying, loading and unloading, handling, sorting, assembling and other applications.
- ★ The safety emergency stop board is independent of the controller, and the safety relay circuit is adopted to provide double circuit emergency stop to ensure the reliability of emergency stop.
- ★ The robot body cables are made of special cables for highly flexible robots.
- ★ Built-in three-phase transformer, 380V and 200V isolation, more stable power supply.
- ★ Power supply requirements can be customized for different countries. Built-in three-phase filter can effectively improve the performance of EMC and EMI.
- ★ The robot body is with dual-circuit gas pipe and meets welding and handling requirements
- ★ The inner diameter of 6-axis middle hole is 46 mm, which can meet the installation requirements of water-cooled gun and bellows gun.
- ★ It's with highly flexible built-in welding cable.

Installation Interface Diagram

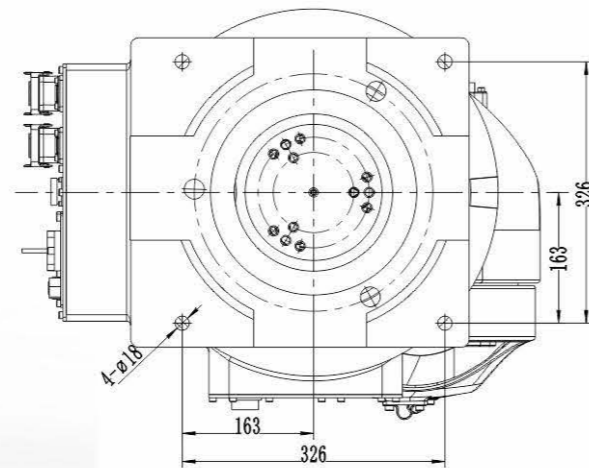

Installation Dimension of Base

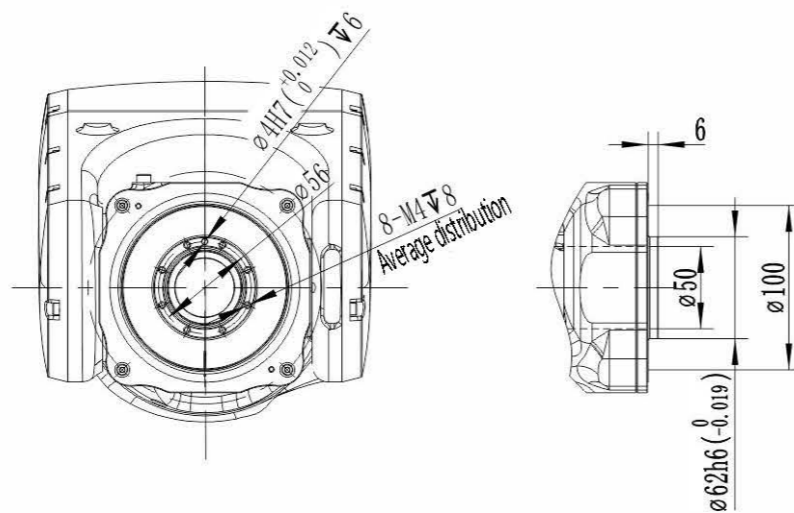

Flange Dimensions

Motion Range Diagram

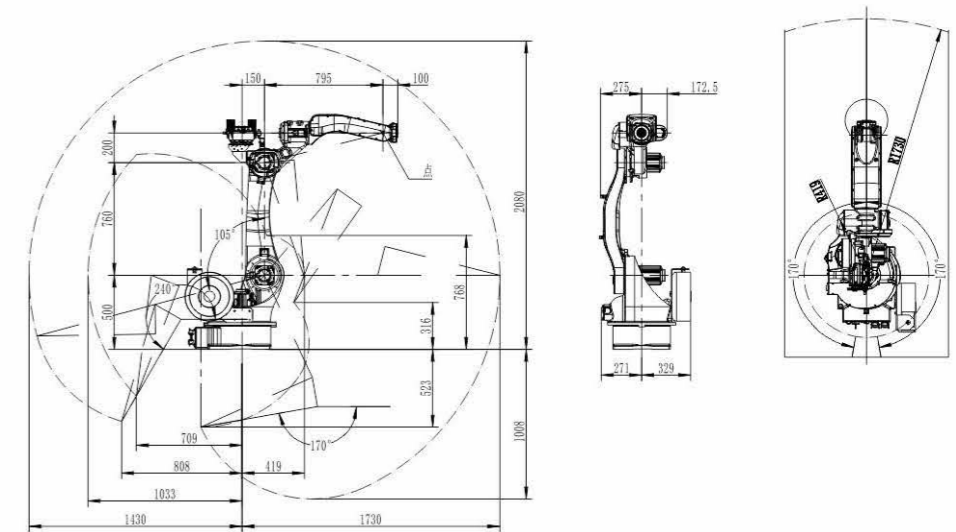

Robot Body Technical Parameters

Model	CRP-RH18-20	
Arm form	Vertical multiple joints	
Degree of freedom	6 axis	
Maximum payload	20KG	
Maximum travel	axis 1	-167° - 167°
	axis 2	0° - 175°
	axis 3	-80° - 150°
	axis 4	-190° - 190°
	axis 5	-105° - 130°
	axis 6	-210° - 210°
Maximum speed	axis 1	159°/S
	axis 2	159°/S
	axis 3	169°/S
	axis 4	280°/S
	axis 5	240°/S
	axis 6	483°/S
Allowable torque	axis 4	48N.m
	axis 5	48N.m
	axis 6	28N.m
Allowable moment of inertia	axis 4	1.8kg.m ²
	axis 5	1.8kg.m ²
	axis 6	0.8kg.m ²
Repeated positioning accuracy	±0.08mm、	
Maximum reaching distance	1720mm	
Robot body weight	285KG	
Installation mode	Ground or upside down mounting	
Installation environment	ambient temperature	0~45°C
	relative humidity	20~80% (No condensation)
	vibration	Under 0.5 G
Others	Robot installation must be away from: Flammable or corrosive liquids or gases, electrical sources of interference	
IP level	IP56	
Advantage features	Compact structure, high speed, high precision, high expansibility and easy operation	
Application	Cutting, assembly, handling, marking, grinding	

CRP-RH14-10-W

Industrial Robot Welding Application



Functional Features

- ★ The arm span is 1.4 meters. It can be installed on the ground or upside down flexibly.
- ★ With large working space and fast running speed, it is suitable for welding, spraying, loading and unloading, handling, sorting, assembling and other applications.
- ★ The safety emergency stop board is independent of the controller, and the safety relay circuit is adopted to provide double circuit emergency stop to ensure the reliability of emergency stop.
- ★ The robot body cables are made of special cables for flexible robots.
- ★ Built-in three-phase transformer, 380V and 200V isolation, more stable power supply. Power supply requirements can be customized for different countries. Built-in three-phase filter can effectively improve the performance of EMC and EMI.
- ★ The robot body is with dual-circuit gas pipe and meets welding and handling requirements
- ★ The inner diameter of 6-axis middle hole is 46 mm, which can meet the installation requirements of water-cooled gun and bellows gun.
- ★ It's with highly flexible built-in welding cable.

Installation Interface Diagram

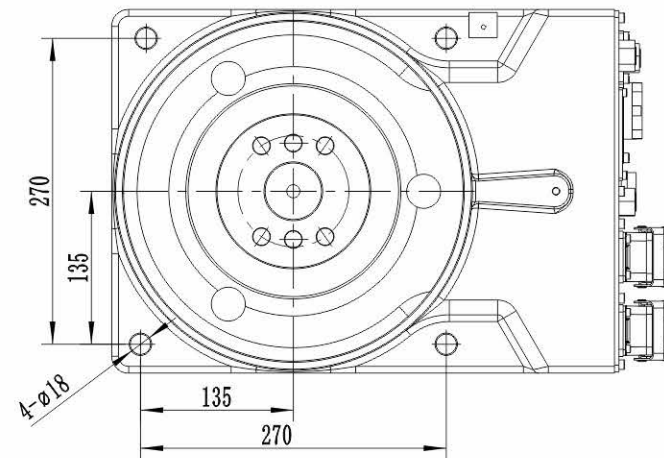

Installation Dimension of Base

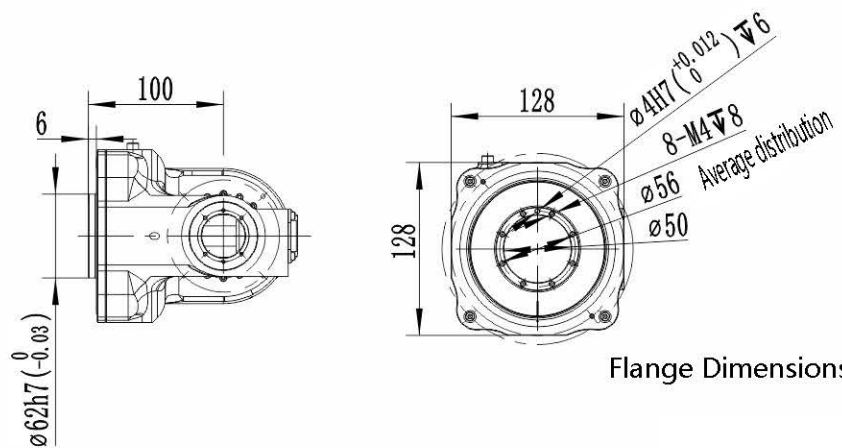

Flange Dimensions

Motion Range Diagram

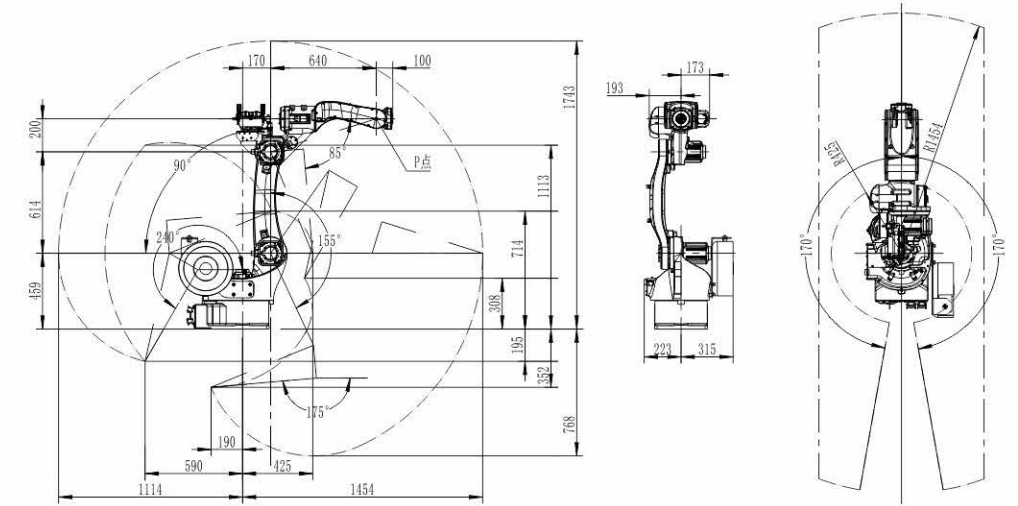

Robot Body Technical Parameters

Model	CRP-RH14-10-W	
Arm form	Vertical multiple joints	
Degree of freedom	6 axis	
Maximum payload	10KG	
Maximum travel	axis 1	-167° - 167°
	axis 2	0° - 175°
	axis 3	-80° - 150°
	axis 4	-190° - 190°
	axis 5	-105° - 130°
	axis 6	-210° - 210°
Maximum speed	axis 1	169°/S
	axis 2	169°/S
	axis 3	169°/S
	axis 4	280°/S
	axis 5	240°/S
	axis 6	520°/S
Allowable torque	axis 4	10N.m
	axis 5	10N.m
	axis 6	3N.m
Allowable moment of inertia	axis 4	0.25kg.m ²
	axis 5	0.25kg.m ²
	axis 6	0.05kg.m ²
Repeated positioning accuracy	±0.08mm、	
Maximum reaching distance	1440mm	
Robot body weight	170KG	
Installation mode	Ground or upside down mounting	
Installation environment	ambient temperature	0~45°C
	relative humidity	20~80% (No condensation)
	vibration	Under 0.5 G
Others	Robot installation must be away from: Flammable or corrosive liquids or gases, electrical sources of interference	
IP level	IP56	
Advantage features	Compact structure, high speed, high precision, high expansibility and easy operation	
Application	cutting, assembly, handling, marking, grinding	

CRP-RH20-10-W

Industrial Robot Welding Application



Functional Features

- ★ With compact design 10kg payload and about 2.0 meters arm span, it can be installed on the ground or upside down flexibly.
- ★ With large working space and fast running speed, it is suitable for welding, spraying, loading and unloading, handling, sorting, assembling and other applications.
- ★ The safety emergency stop board is independent of the controller, and the safety relay circuit is adopted to provide double circuit emergency stop to ensure the reliability of emergency stop.
- ★ The robot body cables are made of special cables for highly flexible robots.
- ★ Built-in three-phase transformer, 380V and 200V isolation, more stable power supply.
- ★ Power supply requirements can be customized for different countries. Built-in three-phase filter can effectively improve the performance of EMC and EMI.
- ★ The robot body is with dual-circuit gas pipe and meets welding and handling requirements
- ★ The inner diameter of 6-axis middle hole is 46 mm, which can meet the installation requirements of water-cooled gun and bellows gun.
- ★ It's with highly flexible built-in welding cable.

Installation Interface Diagram

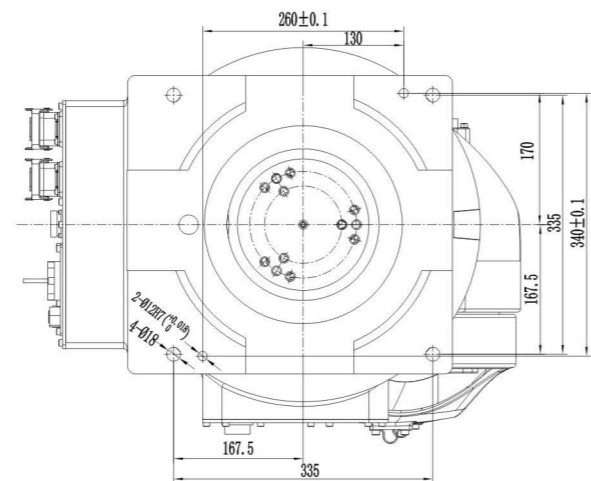

Installation Dimension of Base

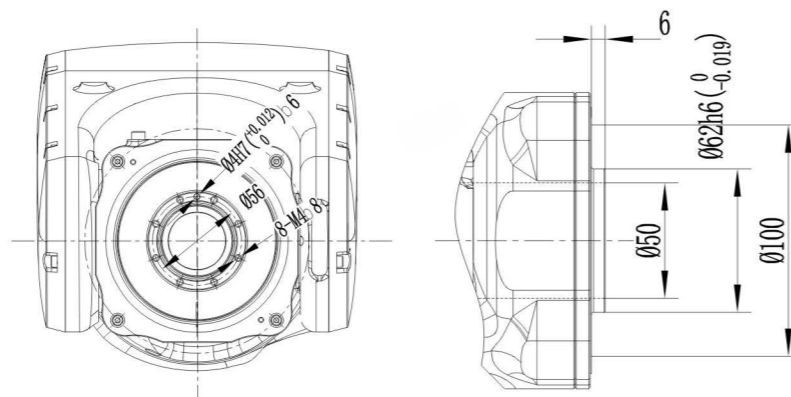

Flange Dimensions

Motion Range Diagram

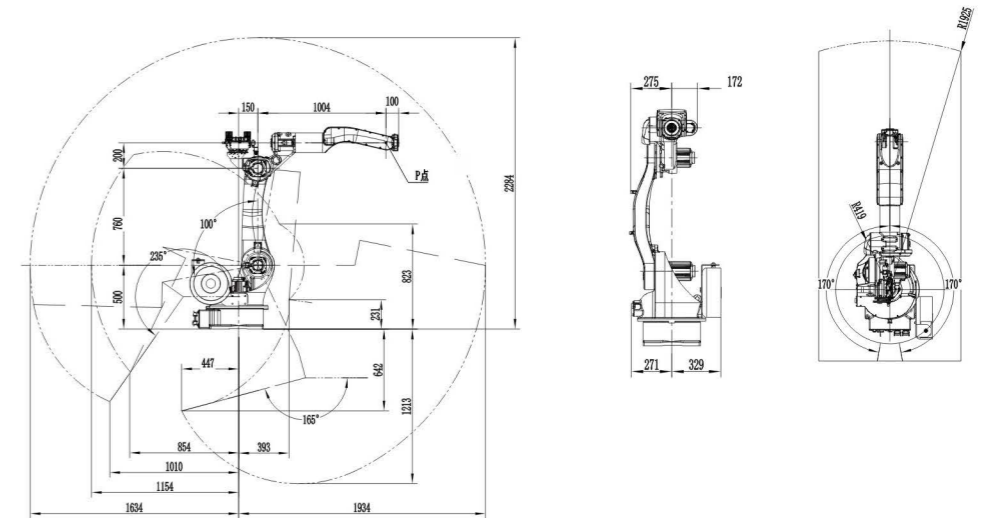

Robot Body Technical Parameters

Model	CRP-RH20-10-W	
Arm form	Vertical multiple joints	
Degree of freedom	6 axis	
Maximum payload	10KG	
Maximum travel	axis 1	Ground/upside down mounting -167°~167°, wall mounting -30°~30°
	axis 2	0° - 175°
	axis 3	-80° - 150°
	axis 4	-190° - 190°
	axis 5	-105° - 130°
	axis 6	-210° - 210°
Maximum speed	axis 1	159°/S
	axis 2	159°/S
	axis 3	169°/S
	axis 4	280°/S
	axis 5	240°/S
	axis 6	483°/S
Allowable torque	axis 4	24N.m
	axis 5	24N.m
	axis 6	14N.m
Allowable moment of inertia	axis 4	1.4kg.m ²
	axis 5	1.4kg.m ²
	axis 6	0.5kg.m ²
Repeated positioning accuracy	±0.08mm、	
Maximum reaching distance	1920mm	
Robot body weight	288KG	
Installation mode	Ground or upside down mounting or wall mouting	
Installation environment	ambient temperature	0~45°C
	relative humidity	20~80% (No condensation)
	vibration	Under 0.5 G
Others	Robot installation must be away from: Flammable or corrosive liquids or gases, electrical sources of interference	
IP level	Body IP54 , wrist IP	
Advantage features	Compact structure, high speed, high precision, high expansibility and easy operation	
Application	Welding, cutting, assembly, handling, marking, grinding	

CRP-RS04-03 CRP-RS06-06 SCARA ROBOTS



Functional Features

- Compact and flexible structure, fast running speed, high transmission accuracy and low noise
- Highly rigid arm design realizes high load and high speed in one package
- Available in 600 and 400 mm arm span; 3kg or 6kg payload.
- Adapt to G3 control cabinet, provide 23 input and 23 output custom IO; support serial port, network, USB and other interface forms
- Suitable for handling, palletizing, assembly, 3C and other application fields.

Dimension Drawing

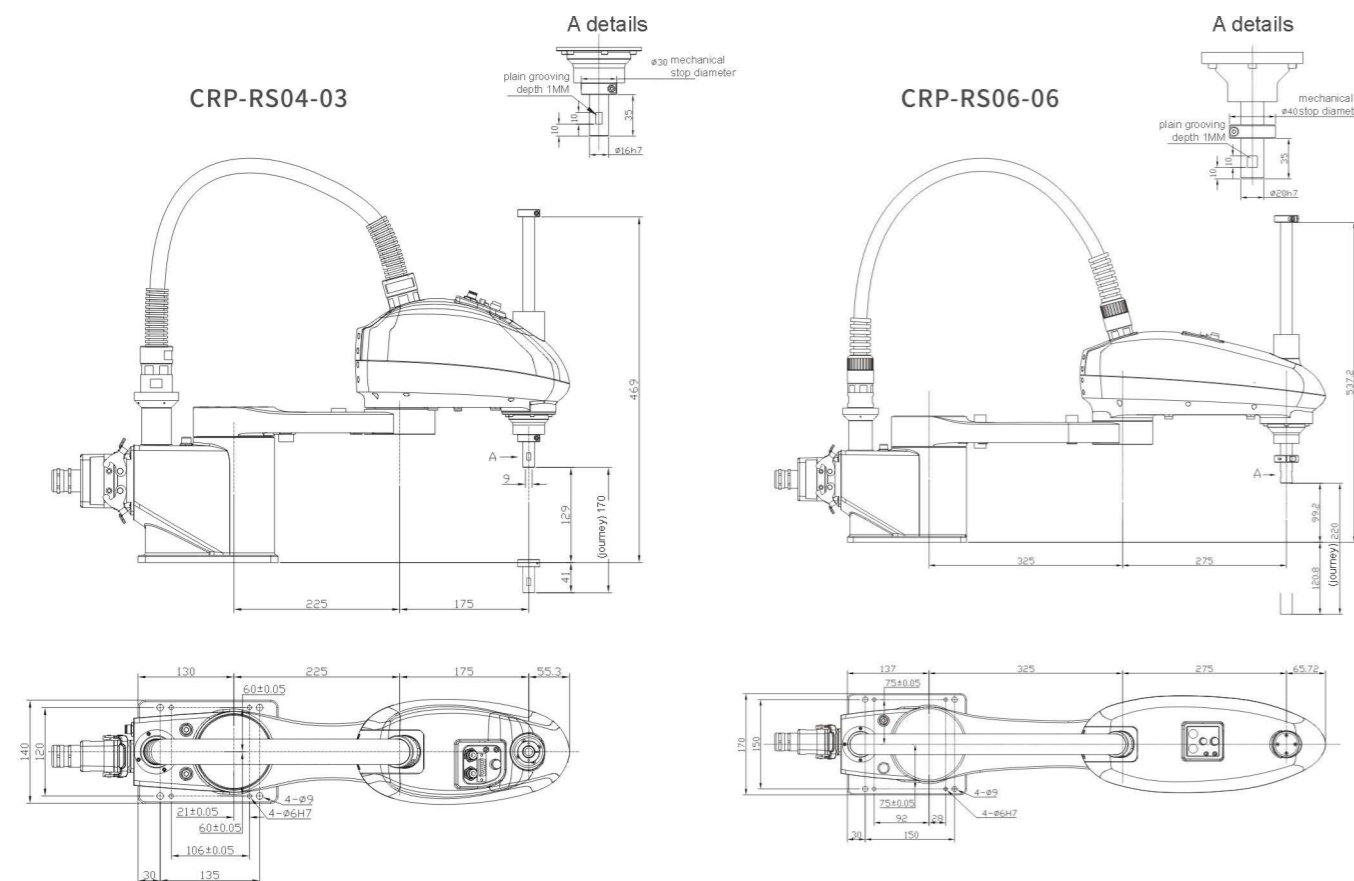

Motion Range

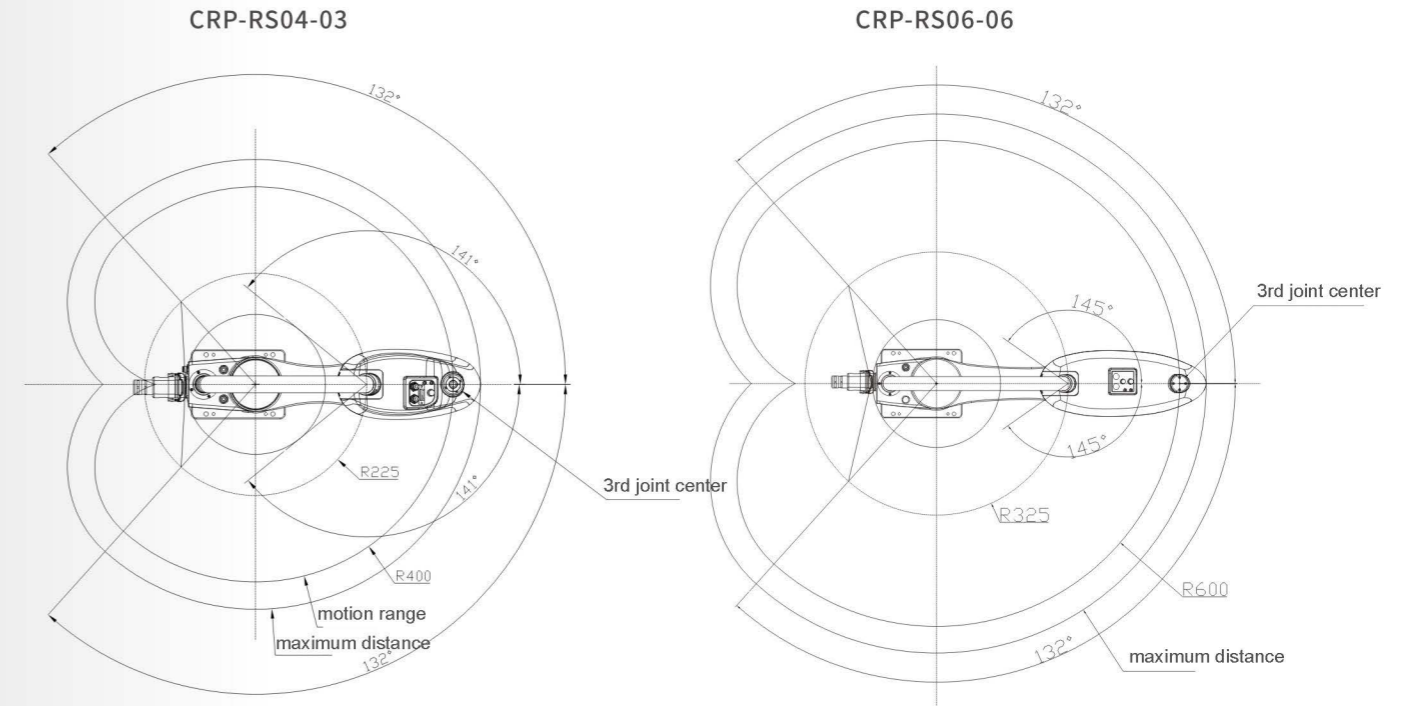

Performance Parameters

Robot Model	CRP-RS04-03	CRP-RS06-06
Function	Material handling, 3C	Material handling, 3C
Total axes	4	4
Maximum reach	400mm	600mm
Payload	Rated load	1kg
	Maximum load	3kg
Permissible inertial torque of rotating axis	Rated torque	0.005kg.m ²
	Maximum torque	0.05kg.m ²
Repeated positioning accuracy	1st axis + 2nd axis	±0.01mm
	3rd axis (elevating axis)	±0.01mm
	4th axis (rotation axis)	±0.01°
Max speed	1st axis	720°/sec
	2nd axis	720°/sec
	3rd axis (elevating axis)	1000mm/sec
	4th axis (rotation axis)	2500°/sec
Max operating area	1st axis	±132°
	2nd axis	±141°
	3rd axis (elevating axis)	170mm
	4th axis (rotation axis)	±360°
Installation method	Floor mounted	Floor mounted
Robot body weight	13Kg	17Kg
Power consumption	0.7kw	0.8kw
Installation environment	Temperature	0~45°C
	Humidity	20~80%RH(no condensation)
	Vibration	Under 4.9M/S ²

CRP-CLW-V2

Laser Seam Tracker



Benefits of laser seam tracker

- Weld safely and perfectly
- Reduce the head load
- Increase productivity
- Place the welding gun in an ideal position
- Compensate production, equipment and operation tolerances
- Reduce programming work for complex workpieces
- Achieve consistent and reproducible connections

Technical Characteristics

- According to different types of sensors, detectable weld width: 0.5mm~35mm
- Height error: < 0.15mm
- Horizontal error: < 0.1mm
- Support RS-232/RS-485, Mod-bus and TCP/IP protocol
- Can be applied in MIG/MAG, TIG, laser and plasma welding
- Various weld shapes for different weld types
- Intelligent recognition of different weld features based on expert fuzzy control
- Real-time display current welding seam offset, width and alignment tolerance, convenient for production management
- Real-time seam tracking, including left and right and high and low tracking
- Laser location
- Strong anti-interference ability and can recognize weld seam accurately under strong arc light interference.
- Strong adaptability, the weld feature can be recognized correctly even when the thermal deformation of the workpiece is serious.
- High precision, the laser seam tracking system can achieve 0.1 mm accuracy.

Process and Interface

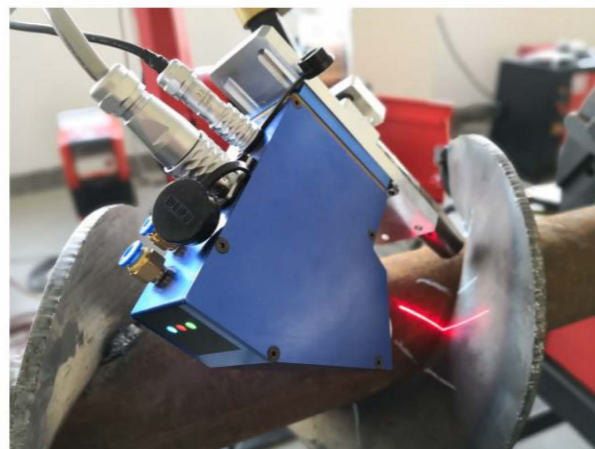

Calibration mode:	absolute	X start points:	0 mm
X axis direction:	positive	Z start points:	0 mm
Z axis direction:	positive		
Preposition distance:	00 mm		
Search sensitivity:	1		
Search X axis scaling:	0.01		
Search Z axis scaling:	0.01		
Real-time tracking sensitivity:	1		
Real-time tracking X axis scaling:	0.01		
Real-time tracking Z axis scaling:	0.01		

CRP - CAW - V1

Arc Tracking Sensor

CRP-CAW-V1 is a own R&D universal type arc tracking sensor, it will not be affected by ,arc light, dust during the working process, so it has high reliability. It can be used under different welding conditions by Fuzzy Control. This sensor can track fillet weld, butt weld, lap weld coordinating with the CRP control system. It's supper convenient and easy to use. It only needs simple adjustment after installation without changing the structure and then it can track the welding. So it can improve the welding productivity for the low precise assembled plate.

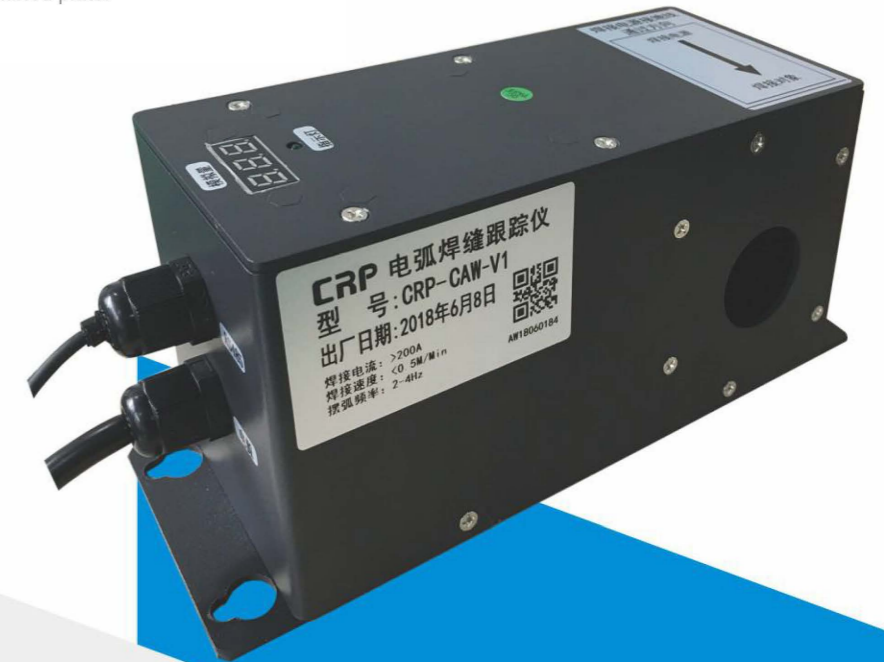

Application condition

- 1.Welding method(shield gas): CO2&MAG
- 2.Wire diameter: 1.0-1.2 mm
- 3.Wire dry extension of electrode: 15-20 mm
- 4.Weld leg length/thickness: >6 mm
- 5.groove angle: <90°

Welding condition

- 1.Welding current: >200 A
- 2.Welding speed: <8 mm/s
- 3.Minimum welding length: 70 cm
- 4.Swing radian: 3-5 mm
- 5.Swing frequency: 2-4 Hz
- 6.Swing type: Z-shape

Process and Interface



Left/right offset parameter	
Left/right offset function	25
Left/right offset sensitivity	0
Left/right offset quantity	0 %
Left/right minimum offset	0 mm
Left/right total maximum offset quantity	200 mm
Left/right maximum offset quantity each time	1 mm
Left/right offset start count	5 eye
Up/down offset parameter	
Up/down offset function	ON
Up/down reference current	0 eye
Offset coordinate system	0 eye
Sampling time	0 eye
Up/down offset sensitivity	25
Up/down offset quantity	0 %
Up/down minimum offset	0 mm
Up/down total maximum offset quantity	200 mm
Up/down maximum offset quantity each time	1.0 mm
Up/down offset start count	0 eye
Up/down reference sampling start count	0 eye
Up/down reference sampling count	0 eye
Up/down reference current constant	0 A

1-axis head and tail stock positioner

(The picture is for reference only; the final product shall prevail in kind.)

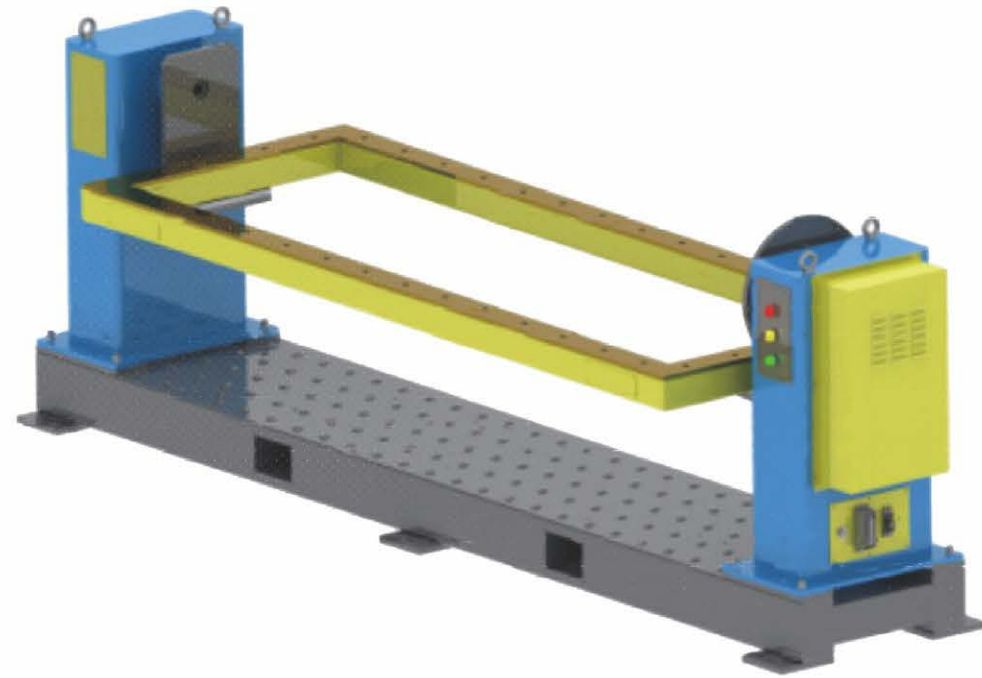

Technical Specification

Specifications not listed can be customized according to requirements

Items	Parameter	Parameter	Parameter
Loading capacity	500KG	800KG	1200KG
	Within R500mm	Within R500mm	Within R750mm
Standard Rotate Radius	R600mm	R700mm	R900mm
Rated Rotate range	±360°	±360°	±360°
Rated Rotate speed	70°/S	70°/S	50°/S
Repeat Location accuracy	±0.10mm	±0.12mm	±0.15mm
Positioning Frame size	2200mm×800mm×90mm	3200mm×1000mm×110mm	4200mm×1200mm×110mm
Machine overall size	2900mm×650mm×1100mm	4200mm×850mm×1350mm	5400mm×1000mm×1500mm
Rotating table	Φ360mm	Φ400mm	Φ450mm
Rotating center height	850mm	950mm	110mm
Power supply	200V ±10% 50Hz 3-P	200V ±10% 50Hz 3-P	200V ±10% 50Hz 3-P
Insulation class	H	H	H
G.W.	about 500kg	about 1000kg	about 1600kg

2-axis positioner

(The picture is for reference only; the final product shall prevail in kind.)

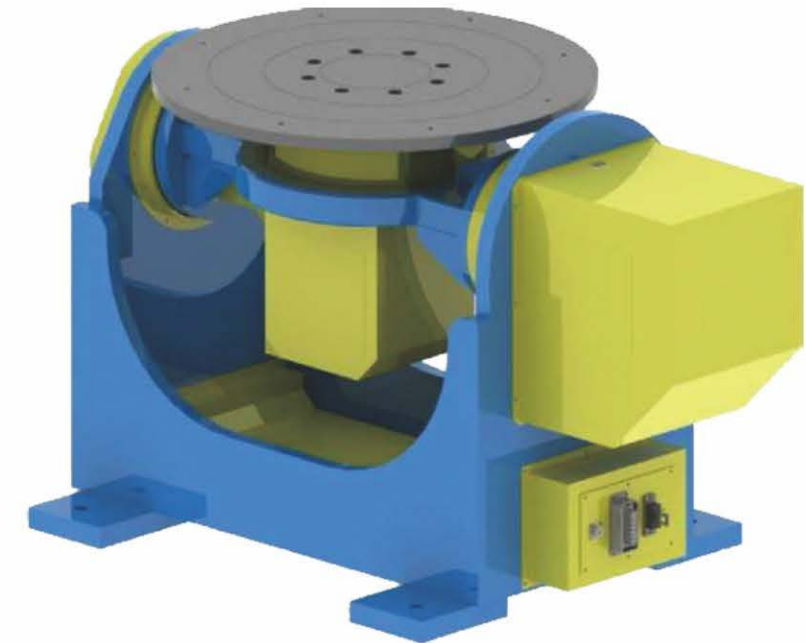

Technical Specification

Specifications not listed can be customized according to requirements

Items	Parameter	Parameter	Parameter
Loading capacity	200kg	500kg	1000kg
	Within axis 2 radius (R300mm)	Within axis 2 radius (R300mm)	Within axis 2 radius (R500mm)
Standard Rotate Radius	R400mm	R400mm	R600mm
Rated Rotate range (J1)	±90°	±90°	±90°
Rated Rotate range (J2)	±360°	±360°	±360°
Rated Rotate speed (J1)	70°/S	50°/S	15°/S
Rated Rotate speed (J2)	70°/S	70°/S	24°/S
Repeat Location accuracy	±0.10mm	±0.12mm	±0.20mm
Machine overall size	1000×550×600mm	1200mm×600mm×750mm	1500mm×750mm×900mm
Rotating table	Φ500mm	Φ500mm	Φ800mm
Rotating center height	500mm	550mm	750mm
Power supply	200V ±10% 50Hz 3-P	200V ±10% 50Hz 3-P	200V ±10% 50Hz 3-P
Insulation class	H	H	H
G.W.	about 300kg	about 500kg	about 1000kg

CRP ROBOT SYSTEM

Introduction of System Function (welding function)

1. Welding (See detail-CRP-S40, S80 Welding Procedure Specification)

• Analog control/Digital communication control

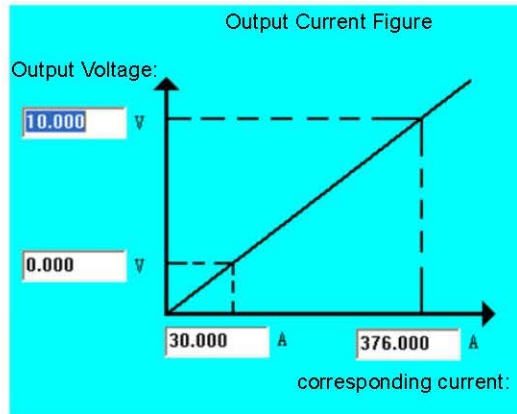

Welding Machine Control Mode: Digital Control Welding Machine Communication State: ●

Power Source Manufacturer: Megmeet

Welding Machine Selection: Enable

Welding Machine Digital Control Settings: DC SYNER

Welding Machine Working Mode:

Communication: RTU232 Controller MAC Address:

Communication Interface: Welding Machine MAC Address:

Analog control: Robot system control the welding machine to start arc, adjust current, voltage, supply gas by I/O and analog output(0-10V). This analog control can easily match various analog interface welding machine.

Digital control: Robot system can communicate current, voltage, arc start, arc end, wire feeding, gas supply, position searching signal with welding machine by CAN communication. Simple wiring, anti-interference. Digital control can communicate with Megmeet, Aotai welding machine.

• Welding process speed and speed rate adjustment

ARCSTART 0 % 100.00 %

mm/s

Welding process speed: In the welding instruction, setting the speed of the motion instruction during the welding process, including line speed (mm/s) and rate speed (%). It's convenient for the debugging process and the test running, run by the practical speed of the instruction during the test running, and run by the setting speed of the instruction during regular welding process.

• Manual wire feeding/withdraw

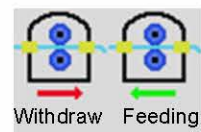

On the teaching pendant there are wire feeding and the wire withdraw button, you can feeding or withdraw the welding wire during the manual mode by the setting speed of the welding machine, it's easy to adjust the wire extension.

• Manual wire jogging out/back

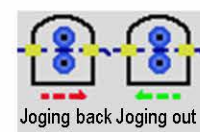

On the teaching pendant there are wire jogging out and jogging back button, you can jogging out or back the welding wire at a setting timing on the manual mode by the setting speed of the welding machine, it's convenient to adjust the wire extension slightly.

• Gas detection

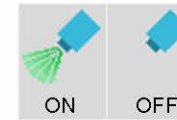

There is gas detection button on the teaching pendant, easy to detect the protective gas.

• Lead-lag gas control

Gas supply lead time : 0.00 sec

Gas supply lag time : 0.00 sec

Lead-lag gas control means supply gas in advance and maintain the gas supply after the welding process is over. Supply gas in advance makes it's easier to start arc and reduce spattering. Maintain the gas supply after the welding process keeps the melton pool isolated from air during the cooling process.

• Simulating welding

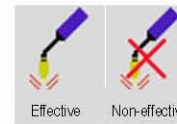

Simulating welding follow the actual welding track but no arc strat, wire feeding, gas supply are carried out. The track and the speed are the same with the actual welding process. There is simulating welding button on the teaching pendant, it can be use to check welding program or repair welding.

• Arc break detect

Once the arc breaks during the welding process the system will stop the robot and ring the alarm, avoiding leak welding.

• Arc break point maintain

If the arc breaks during the welding process the robot will record the arc breaking point, after examination and rule-out the robot will start the program from the same command line of the arc break point, and the robot will run to the arc break point then start arc. The arc break point will be removed after the program or the welding process reset.

• Welding monitoring

Welding Monitoring

Output Current	Output Voltage
Feedback Current	Feedback Voltage
Wire Feeding Speed	Welding Time
Run Time	Duty Cycle

00 V
0.0 V
0.000 m/min
0.000 S
0.000 S
0 %

A V Welding monitoring

Welding monitoring can directly examine: current, voltage, welding time, program function time, duty cycle, etc. It's convenient for the program analysis and optimization.

• Short weld length control

Because the grid type workpiece have a short weld length and multi welding point, CRP has optimize algorithm and track plan to realize short-distance quick start and stop, so it's effecient.

CRP ROBOT SYSTEM

Introduction of System Function (welding function)

• Position Searching

• Starting Point Searching

Contact-type position searching: Using the welder as the medium, the robot uses the welder signal. The welder applies a forward voltage to the positive electrode of the welding torch. When the wire contacts the workpiece (the negative electrode of the welder), the positive voltage of the welding torch is pulled down to judge the contact of the wire with the workpiece. The robot then records the point. When the displacement of the next workpiece changes, the same contact method is used to record the position after the offset, and the robot calculates the error between the two points by the command to compensate to the working path.

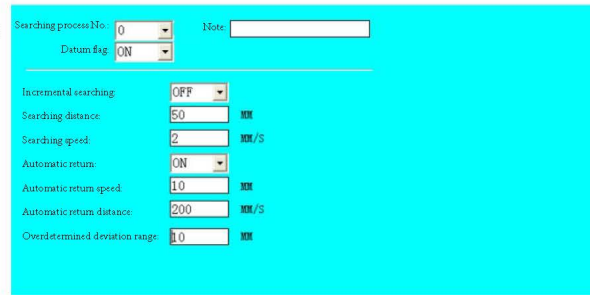

• Laser Position Searching

Using the laser tracker as the medium, the robot is equipped with a laser and runs on the locating path. When the laser searches for the position of the weld that meets the requirements, the feedback signal is given to the robot. The robot uses the signal fed back by the laser to find the welding position. The strating point searching function is suitable for welding starting point deviation, and the subsequent track uses arc or laser tracking.

Note: Laser position searching only support Chuangxiang and Junnuo brands.

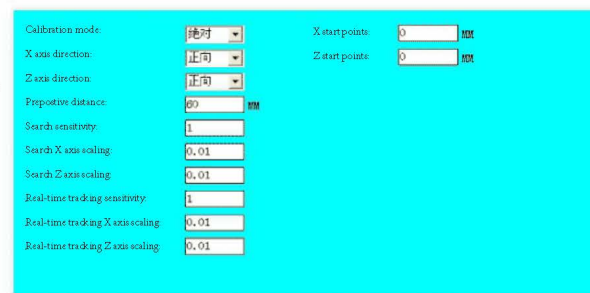

• Whole Position Searching

When the workpiece is offset as a whole, the position can be found by multi-point contact searching, and the deviation of each point can be found by counting the whole offset; then Then sort the deviation path by OFFSETSTART. Can be achieved: fillet weld(1D, 2D, 3D, 2D+, 3D+); inner and outer diameter; point; camera, plane, etc

The whole position searching function is suitable for occasions where the workpiece is prone to whole offset, partial offset, etc.

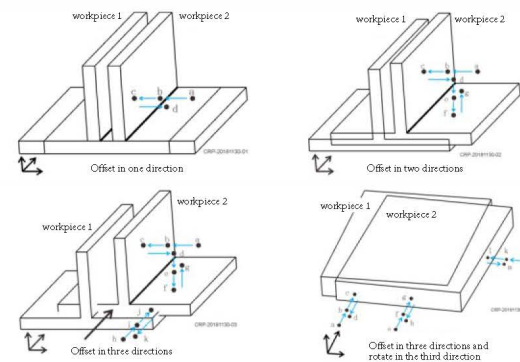

• Welding Process / Parameter Control

• Welding Process Number

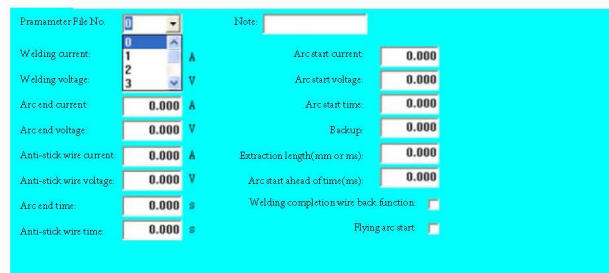

• Welding parameter control

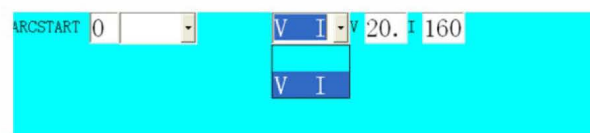

Welding commands support adjustment of welding current and voltage. It is convenient for customers to directly adjust the welding parameters in the welding procedure.

Taking welding related parameters: welding current and voltage, arc starting current and voltage, arc ending current and voltage, anti-stick wire current and voltage, arc starting time, arc ending time, anti-stick wire time, welding completion wire drawing time and flying arc starting time as a parameter package, which is convenient for welding commands to call directly.

• Anti-collision Detection

On the robot-specific terminal board, there is a set of special anti-collision detection signal interface. With the anti-collision detection switch attached to the welding torch or other fixture, the robot can be stopped in time when the welding gun or fixture collides with the workpiece or tooling, so as to minimize damage to equipment.

• Wire Back

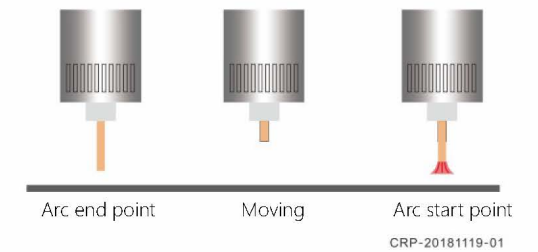

When this function is enabled, the welding wire will automatically retract when the robot is on the way to the next welding seam (idle walk) after the completion of welding of one welding seam, so as to avoid the occurrence of bending of welding wire caused by collision with workpiece or fixture, etc., then realize the successful arc starting of subsequent welding.

• Flying Start

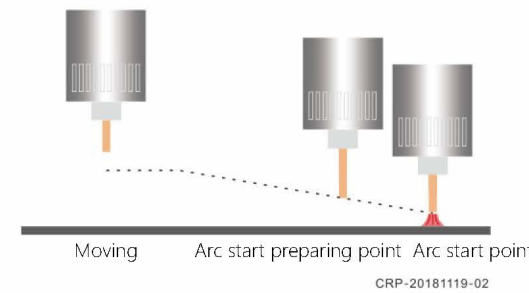

In the general process of arc starting, when the robot reaches the welding starting point (arc starting point), the robot will stop and issue the arc starting command. The wire feeding machine will send the wire forward slowly until the welding wire touches the base metal and successfully start the arc. But flying arc start refers to that before the robot reaches the welding starting point (arc starting point), the robot starts to execute the arc starting command in the running process and starts to feed the wire slowly. When the robot reaches the welding starting point, the welding wire touches the base metal and successfully start the arc. Thus shortening the welding time.

• Restart (Lap Welding)

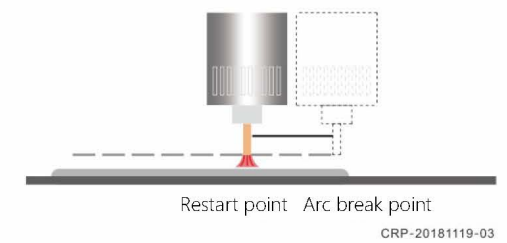

When this function is enabled, if it needs to be re-welded, while arc breaking or welding suspension occurs during the welding process. The robot will automatically retreat a certain distance along the welding forward direction, and overlap with the previous arc stopping points to avoid bad results. This function is suitable for girth welding or welding of products with sealing requirements.

• Linear / Arc Coordination (COORD)

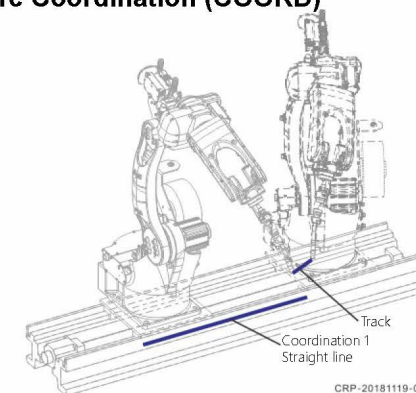

Linear Coordination: The external axis is a straight axis, which can be attached to any one or two directions coincident with the geodetic coordinates X, Y and Z of the robot, and together with the 6 axes of the body to form a 7 / 8 axis linkage to carry out interpolation motion. That is, in the process of motion of the external straight axis, the end of the robot can still maintain straight line or circular arc interpolation motion. Suitable for robot arm expansion is not enough but need continuous work applications. Such as: welding of super-large parts, super-long soldering seam, etc.

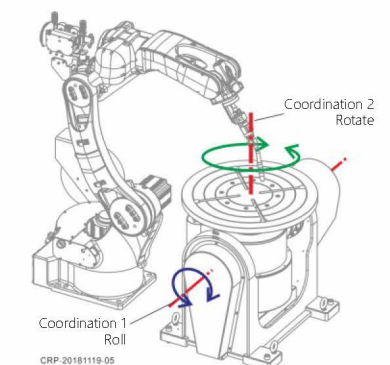

Rotating Coordination: The external axis is a rotating axis, which can be equipped with one or two additional rotating axes. The rotating axes can be turned and rotated, and 7/8 axes can be combined with the 6 axes of the body for interpolation. That is to say, the external rotating axis can still maintain linear or circular interpolation motion at the end of the robot. It is suitable for applications where robot gesture coverage is insufficient, but continuous operation is needed, such as intersecting line welding, whole gesture circular welding, etc.

CRP ROBOT SYSTEM

Introduction of System Function (welding function)

• Swing Arc

Swing arc function is suitable for wide welding, groove filling, cover and other welding occasions

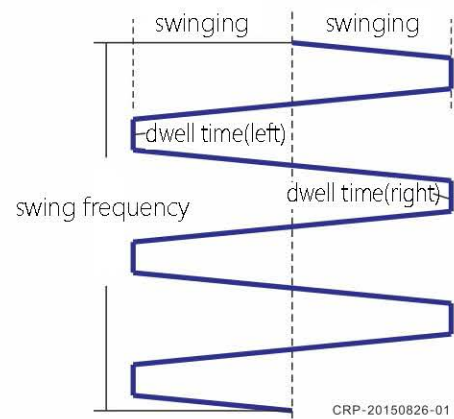

Z-shaped swing: The trajectory of the robot is shaped like the letter "Z", the direction of oscillation is perpendicular to the direction of advance, and the swing surface is perpendicular to the z-axis of the tool coordinate system

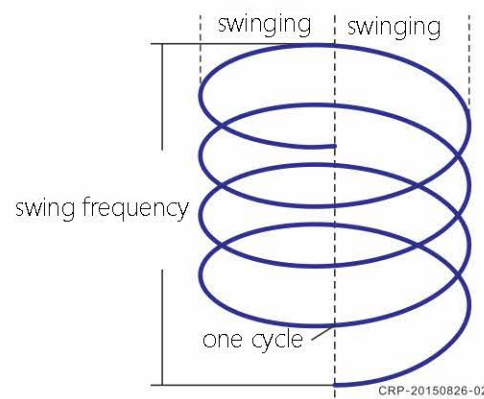

Circular arc: the robot's motion trajectory is like the spiral arc alternation. The swing direction is perpendicular to the forward direction, and the swing surface is perpendicular to the z-axis of the tool coordinate system.

• Gradual change/Jump

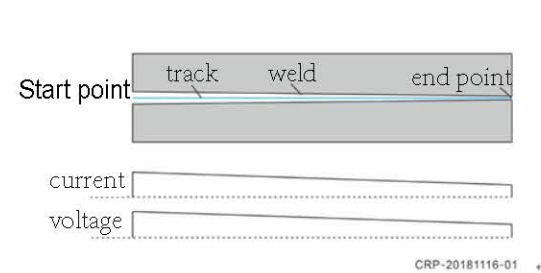

```

1 MOVJ VJ=100.0% PL=0
2 ARCSTART#(0) V= 20.00V I= 160.00A
3 MOVL VL=10.0MM/S PL=0 AOUT V=23.0 I=220.0

```

The gradual change function can be used in welding places that need gradual change of current and voltage. During the execution of welding operation, the welding machine current and voltage parameters can be controlled to gradually increase or decrease, and the gradual change process is linear. The whole position searching function is suitable for occasions where the workpiece is prone to whole offset, partial offset, etc.

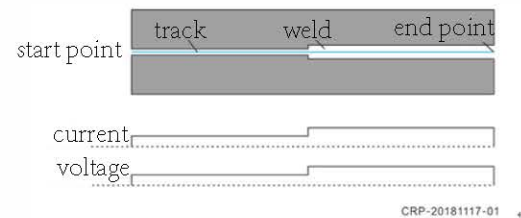

```

1 MOVJ VJ=100.0% PL=0
2 ARCSTART#(0) V= 20.00V I= 160.00A
3 MOVL VL=10.0MM/S PL=0
4 ARCSTART#(0) V= 23.00V I= 220.00A
5 MOVL VL=10.0MM/S PL=0
6 ARCEND#(0)

```

The jump function can be used in complex welding, where different parameters need to be matched. During the execution of welding action, the current and voltage parameters of the welding machine can be controlled to jump up or down, and the jump process can be completed instantaneously.

• Fish scale welding

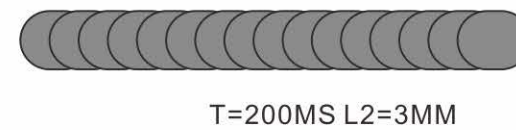

Fish scale welding is also known as continuous spot welding, in the process of progress, continuous arc start, and then arc over, weld molding such as fish scale general effect. This function combination, can also achieve intermittent welding, reduce the programming workload. Mainly used in pipe fitting welding (beautiful appearance), thin plate welding (not too hot melt through the base material), or intermittent welding and other places.

• Arc tracking

The robot system adopts the swing welding method, and collects the current fluctuation caused by the change of arc length in the welding process through the external arc sensor, so the welding seam and track the deviation. Suitable for medium and thick plate welding and large welding location with deviation and other welding places.

Note: this function needs to cooperate with crp-caw-v1 arc tracker

• Laser tracking

The robot system collects the welding seam position through the external laser tracking sensor, and then corrects the path and tracks the deviation in real time. It is suitable for welding occasions such as difficult positioning of tooling or inaccurate positioning, deformation of workpiece during welding and inaccurate incoming materials.

Note: this function needs to cooperate with CHUANGXIANG and JUNNUO laser tracker

• Fixed-Point Laser tracking

Laser fixed point tracking is usually an application mode of laser tracking welding with the external axis. In the laser tracking process, the body position and posture remain basically unchanged, and the welding seam is moved by the rotation or translation of the external axis. The deviation in the laser search process is finally compensated to the welding track. Fixed point tracking is suitable for welding scenes such as large and small circles, multi-circles and long straight lines, and it can also solve the track error problem which is easy to occur in the process of large attitude change.

• Multi-layer and multi-path

This is a welding method commonly used in the field of welding, the same weld or the same path for repeated stack welding, so as to meet the welding height and overall welding strength requirements. The multi-layer multi-path function only needs to teach the basic path once, and then design the stacking times and stacking rules of the welding path through the instruction. Greatly reduce the programming time, reduce the difficulty of programming. Multi-layer multi-channel is suitable for the need to use stacked welding. It is also suitable for other sports occasions that need to run similar trajectory, such as glue coating, spraying and other fields.

CRP ROBOT SYSTEM

Introduction of System Function (painting, bending, palletizing)

2. Painting

The system provides 4-way analog interface for painting. Built-in standard trace templet. Quickly generate the painting trace. Support user-defined painting trace. For details see *CRP-S80 Painting Instructions*.

• Analog Interface

Four-way analog output, easy to control fan-shaped, atomization, flow, air pressure or other painting equipments



• Trace Templet

File name: 029
Time: 0
Motion mode: 垂直平 (Vertical Flat), 圆弧面寸动 (Arc Face Inching), 寸动直线 (Straight Line)Position 1 speed: 55 mm/s, Position 2 speed: 100 mm/s, Position 3 speed: 110 mm/s, Position 4 speed: 100 mm/s

Flat inching, Flat, Arc line, Arc face inching, Arc face, Straight line

3. Bending

The bending process is mainly applied to the loading and unloading of the bending industry, and the bending follows of the workpiece. Strong consistency with 24-hours work without interruption. Substitute manual work to realize unmanned and automation. It can realize constant speed tracking (old bending equipment), sensor (grating, encoder), real-time tracking (CNC bending machine). The system commands can realize bending follow and automatically back to flat function. For details see *CRP Bending Process Instructions*.



Bending follow process No: 0
Note:
Bending work coordinates: Whether to use external sensor: ON, Bending user coordinates: 1
Record point: P1, Lower die V-groove width v: 4 mm, V-groove depth a: 8 mm
Record point: P2, Grating ruler: 0, Grating distance ratio: 0
Checkler:
Bending angle:
Bending speed:
Bending acceleration time:
Bending delayed distance:
Descending distance: 0 mm, Distance between tool edge and back stop:
Descending speed: 1 mm/s, Distance between L1 and L2:
Descending acceleration time: 50 ms, L1 in place distance:
Descending delayed distance: 0 mm, L2 in place distance:
Back distance: 0 mm, Back to flat speed: 1 /s
Back speed: 1 mm/s, Back to flat acceleration time: 50 ms

User coordinates verification
User coordinates No:
Record point: ORG值
ORG Value: XX Direction, YY Direction

4. Palletizing

The palletizing process refers to the simple confirmation of the placement position of the crucible by setting the basic parameters of the outer dimensions, the number of pallets, and the number of layers. Palletizing and unpacking can be achieved with a simple palletizing command. For details see *CRP-S40, S80 Palletizing Process Instructions*

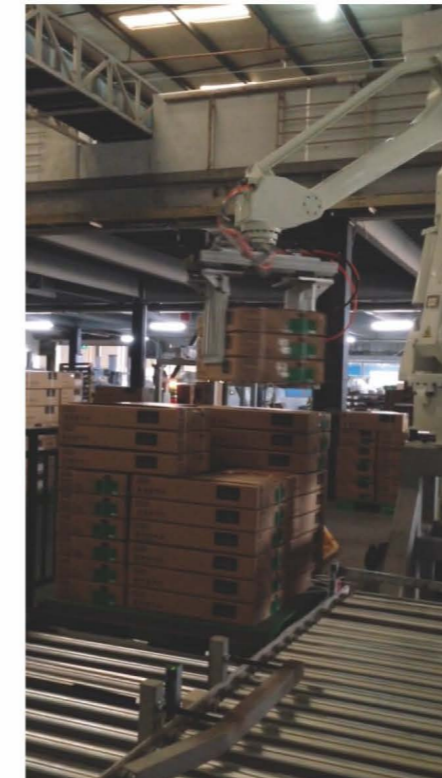

Layout number(1-99): 1
Base size settings (1-99): Length: 1, Width: 1, Height: 1
Workpiece size settings (1-99): Length: 1, Width: 1, Height: 1
User coordinates num (1-49): 2
Reference point record complete

Layout 1 setting
Pallet 1 x: 0.0, y: 0.0, z: 0.0, θ: 0.0
Pallet 2 x: 0.0, y: 0.0, z: 0.0, θ: 0.0
Pallet 3 x: 0.0, y: 0.0, z: 0.0, θ: 0.0
Pallet 4 x: 0.0, y: 0.0, z: 0.0, θ: 0.0
Pallet 5 x: 0.0, y: 0.0, z: 0.0, θ: 0.0
Pallet 6 x: 0.0, y: 0.0, z: 0.0, θ: 0.0
Pallet 7 x: 0.0, y: 0.0, z: 0.0, θ: 0.0
Pallet 8 x: 0.0, y: 0.0, z: 0.0, θ: 0.0
Pallet 9 x: 0.0, y: 0.0, z: 0.0, θ: 0.0
Pallet 10 x: 0.0, y: 0.0, z: 0.0, θ: 0.0

Reference point
Pallet 1 coordinates: X=0 Y=0 Z=0 θ=0
Pallet 2 coordinates: X=26 Y=0 Z=0 θ=90
Pallet 3 coordinates: X=26 Y=26 Z=0 θ=180
Pallet 4 coordinates: X=0 Y=26 Z=0 θ=90(270)

Column number: 1
Preparation Point Offset: x: 0.000, y: 0.000, z: 0.000, θ: 0.000
Leaving Point Offset: x: 0.000, y: 0.000, z: 0.000, θ: 0.000

Note:
1. User coordinates X axis indicates columns.
Y axis indicates rows.
2. Just input column number
3. The gray arrow direction indicates the order of stacks.
Arrow parallel with X axis: put columns first, then rows.
Arrow parallel with Y axis: put rows first, then columns.

Layer number corresponding layout settings
Layer 1: 1
Layer 2: 2
Layer 3: 1
Layer 4: 2
Layer 5: 2
Layer 6: 1
Layer 7: 1
Layer 8: 2

CRP ROBOT SYSTEM

Introduction of System Function (vision, track, stamping)

5. Vision

• Plane Vision

Plane vision support multiple vision equipments and protocols(OMRON, Cognex, DALASA, etc). Three trigger mode: construction, timing, distance. Applied in conveyor sortation. It's with the application of one camera working with multiple robots. Camera can be fixed at the end of the robot body or other external devices, identifying, grabbing, vision correction. See more details-CRP-S40, S80 Vision Fuction Brochure.

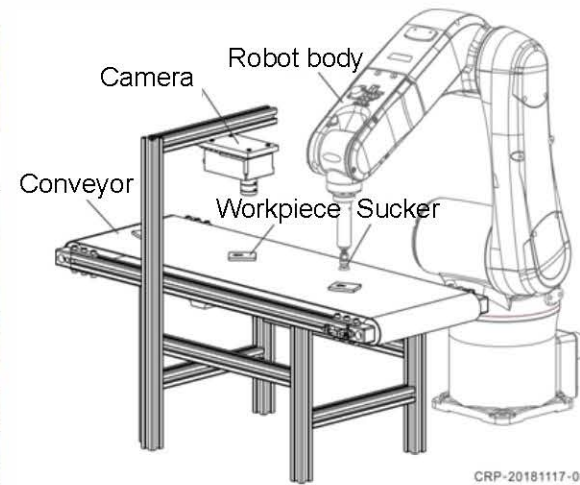
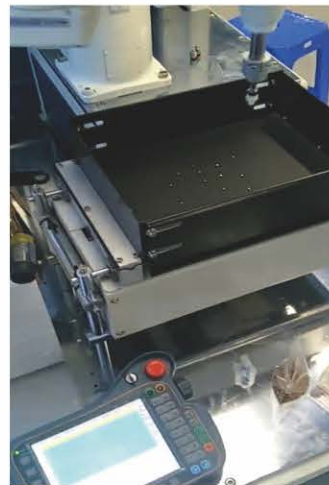

• 3D Vision

Through 3D laser skin on the scattered objects, unordered parts, the robot system can form a 3D image of these parts, then calculate the posture and position of these skinned parts, sothe robot can conduct all-attitude capture operation. Unlike plane vision(2D), 3D vision can do height identification, ABC all-attitude identification, so it can applied in different height overlapping and unordered vision identification.



6. Tracking

Trcaking means the robot can grasp parts following the movement of the conveyor(point track) or the robot move following the movement of the conveyor(trace tracking, e.g. spraying, gluing) Tracking function can realize: current product single tracking(grasp, spraying), multiple tracking(assembling), queue tracking. Setting tracking detect point, start point, stop point, detect range according to different application. Flexible parameter setting, suits conveyor crawl. More detail on CRP-S40, S80 Tracking Fuction Brochure.



7. Stamping

Stamping process is based on CRP standard controller, including all controller fuctions. At the same time developed: stamping process, stamping interface, stamping cable and a whole set of solutions. Fast connection, easy to use, easy maintenance, adjustable beat.

Main feature:

1. Fast connection, bus communication, no complex I/O cable, low failure rate, easy maintenance.
2. Disconnection detection, robot will ring the alarm right after the disconnection, the automation line will wait till the alarm is cleared.
3. Based on the standard controller, all controller functions available.
4. Dedicated stamping interface, hide all the other information that is not rlated with stamping, clear interface.
5. Modularization programming, built-in standard stamping process, it only need record points to start, no complicated teaching line by line.
6. Built-in multi working program block, all you have to do is insert the program block. Can be applied in multi working scenario.
7. Authority management, right man to do the right thing.
8. No external master control needed, one-button enable, one-button start, one-button reset.
9. Built-in detection logic for each process, the robot system will ring the alarm right after something is wrong, easy maintenance and safer.
10. Physical emergency stop curcuit related to every safety switch, reliable and safe.
11. Directing display: working beat, workpiece count, remaining workpiece count, etc.
12. Parameter open, easy to adjust working speed and working beat.
13. Built-in sample run and no-load run, so it's convenient for debugging and testing.

